



HLA 6120 LOOP ANTENNA 9 kHz to 30 MHz



HLA 6120

- Low flat antenna factor
- Useable with most test receivers
- Pulse overload warnings

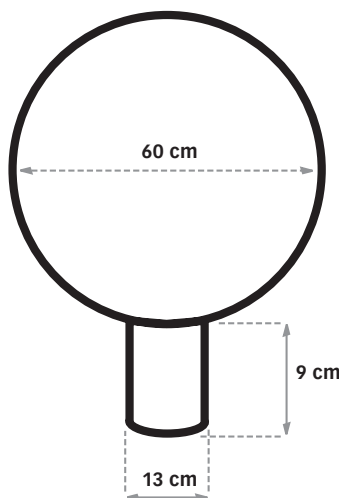

HLA 6120, dimensions

The HLA 6120 is ideal for the 3 m magnetic field measurements as required e.g. by CISPR 11 (reference CISPR 16-1-4 and CISPR 16-2-3) and FCC 18. The built-in preamplifier matches the extremely low impedance of the loop to the measuring receiver. The HLA 6120 has a virtually constant factor over the whole of its frequency range, making it ideal for swept measurement systems.

Overload Warnings for Confidence of Measurement

One of the main reasons active HF antennas have not been widely accepted is the lack of overload warnings. With the HLA 6120 overload indications are given when signals are present at a level likely to cause nonlinearity in the preamplifier and thus impair the integrity of the measurement. This important feature detects the presence of high level signals, either pulsed or continuous, and gives a warning. Even single pulses (clicks) can be detected. For unattended measurements, a hold facility can be used. When the antenna is used remotely, TTL level logic signals provide a warning indication.

Power Sources

The antenna is powered by an external power supply / battery pack (CBP 9720), allowing operation both near to a mains power supply and in remote applications.

Technical specifications

Frequency range:	9 kHz to 30 MHz
Antenna factor:	20 dB (typical)
Maximum measurable field:	>137 dB μ V/m (7 V/m)
Overload threshold:	140 dB μ V/m (10 V/m)
Output voltage into 50 Ω :	>2 V p-p
Output impedance:	50 Ω
Warnings (LED):	low power / signal overload
Max current of remote outputs:	30 mA
Voltage requirements (internally regulated):	\pm 12 V to \pm 20 V
Voltage requirements (battery):	\pm 8.5 V to \pm 12 V
Current requirements (max signal):	\pm 80 mA
Current requirements (typical no signal):	\pm 40 mA
RF connector:	BNC
Power/remote connector:	8 way locking (screened)
Operating temperature range:	0 to 50 $^{\circ}$ C
Mounting thread:	5/8 UNEF
Loop diameter:	600 mm
Size L xW in mm:	620 x 700
Weight:	approx. 2 kg
Recommended tripod:	CTP 6099

HLA 6120 LOOP ANTENNA 9 kHz to 30 MHz



HLA 6120, view to the panel

Typical antenna factor

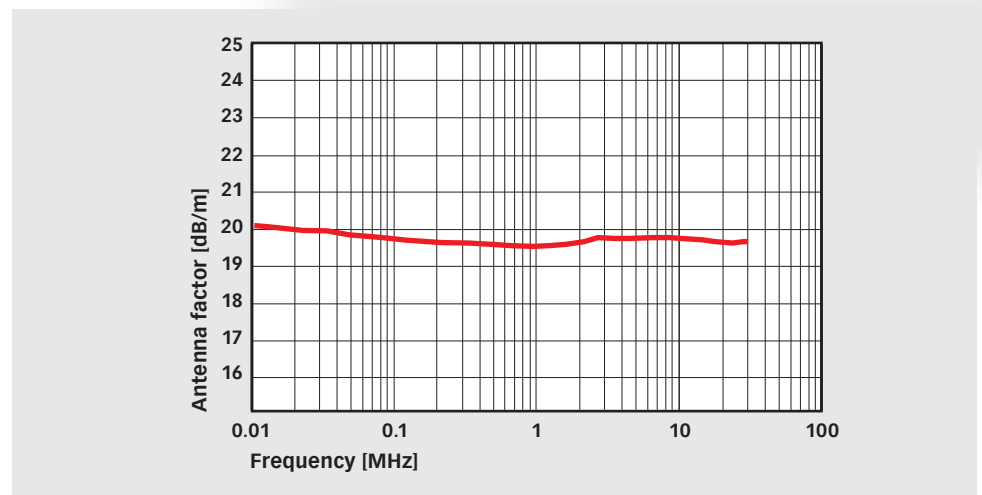

CBP 9720 (battery pack and power supply)

Technical specifications CBP 9720 (battery pack and power supply)

Power supply requirements:	90 V to 126 V or 207 V to 253 V, AC 45 Hz to 63 Hz
Fuse:	6.3 x 32 mm, type F
for 220 V/240 V:	160 mA
for 100 V/120 V:	250 mA
Nominal output voltage:	±9.6 V
Fuse:	2 x 160 mA, 5 x 20 mm, type T
Charging time:	16 h
Operating time (25°C):	>16 h
Mains connector:	IEC 60320 C14
Output connector:	8 way locking DIN
Operating temperature range:	0 to 45 °C
Size L x W x H in mm:	210 x 128 x 80
Weight:	approx. 1150 g



HLA 6120 LOOP ANTENNA 9 kHz to 30 MHz



HLA 6120 onto tripod CTP 6099

Delivery information

Part number	Description
346-455	HLA 6120 RF Loop antenna 9 kHz - 30 MHz complete with universal power supply/ battery pack
97-244570	Ant Cert-TC Traceable calibration (ISO17025), order only with the antenna, free space calibration (horizontal), other calibrations on request
348-053	CTP 6099 Tripod (special for outdoor applications), suitable for HLA 6120
348-100	CAS 6000 Tripod set, includes tripod CTP 6099, cable 10 m BNC(m)-BNC(m), adapter N(m)-BNC(f) and transit case, suitable for HLA 6120
348-102	CAS 6002 Tripod set, includes tripod CTP 6099, cable 10 m BNC(m)-BNC(m), 10 m N(m)-N(m), adapter N(m)-BNC(f), glasfiber tubes with 1 m and 105 mm CAS 6021 and 6022, CAS 6020 mast top, mounting head CAS 6023 and transit case
348-112	CAS 6012 Tripod set, includes tripod CTP 6099, cable 10 m BNC(m)-BNC(m), 10 m N(m)-N(m), adapter N(m)-BNC(f), glasfiber tubes with 1 m and 105 mm CAS 6021 and 6022, CAS 6020 mast top and mounting head CAS 6023
348-115	CAS 6015 Tripod set, includes tripod CTP 6099, glasfiber tubes with 1 m and 105 mm CAS 6021 and 6022, CAS 6020 mast top and mounting head CAS 6023