

AETECHRON®



7224

Operator's Manual

Single-Channel Industrial Amplifier for Demanding, High-Power Systems

Limited One-Year Warranty

SUMMARY OF WARRANTY

AE TECHRON INC. of Elkhart, Indiana (Warrantor) warrants to you, the ORIGINAL COMMERCIAL PURCHASER ONLY of each NEW **AE TECHRON INC.** product, for a period of one (1) year from the date of purchase, by the original purchaser (warranty period) that the product is free of defects in materials or workmanship and will meet or exceed all advertised specifications for such a product. This warranty does not extend to any subsequent purchaser or user, and automatically terminates upon your sale or other disposition of our product.

ITEMS EXCLUDED FROM WARRANTY

We are not responsible for product failure caused by misuse, accident or neglect. This warranty does not extend to any product on which the serial number has been defaced, altered, or removed. It does not cover damage to loads or any other products or accessories resulting from AE TECHRON INC. product failure. It does not cover defects or damage caused by the use of unauthorized modifications, accessories, parts, or service.

WHAT WE WILL DO

We will remedy, at our sole discretion, any defect in materials or workmanship by repair, replacement, or refund. If a refund is elected, you must make the defective or malfunctioning component available to us free and clear of all liens or other encumbrances. The refund will be equal to the actual purchase price, not including interest, insurance, closing costs, and other finance charges less a reasonable depreciation on the product from the date of original purchase. Warranty work can only be performed at our authorized service centers or at our factory. Expenses in remedying the defect will be borne by **AE TECHRON INC.**, including one-way surface freight shipping costs within the United States. (Purchaser must bear the expense of shipping the product between any foreign country and the port of entry in the United States and all taxes, duties, and other customs fees for such foreign shipments.)

HOW TO OBTAIN WARRANTY SERVICE

When you notify us of your need for warranty service, we will give you an authorization to return the product for service. All components must be shipped in a factory pack or equivalent which, if needed, may be obtained from us for a nominal charge. We will take corrective actions within a reasonable time of the date of receipt of the defective product. If the repairs made by us are not satisfactory, notify us immediately.

DISCLAIMER OF CONSEQUENTIAL AND INCIDENTAL DAMAGES

You are not entitled to recover from us any consequential or incidental damages resulting from any defect in our product. This includes any damage to another product or products resulting from such a defect.

WARRANTY ALTERATIONS

No person has the authority to enlarge, amend, or modify this warranty. The warranty is not extended by the length of time for which you are deprived of the use of this product. Repairs and replacement parts provided under the terms of this warranty shall carry only the unexpired portion of this warranty.

DESIGN CHANGES

We reserve the right to change the design of any product from time to time without notice and with no obligation to make corresponding changes in products previously manufactured.

LEGAL REMEDIES OF PURCHASER

There is no warranty that extends beyond the terms hereof. This written warranty is given in lieu of any oral or implied warranties not contained herein. We disclaim all implied warranties, including, without limitation, any warranties of merchantability or fitness for a particular purpose. No action to enforce this Warranty shall be commenced later than ninety (90) days after expiration of the warranty period.

AE Techron, Inc.

Customer Service Department
2507 Warren Street
Elkhart, IN 46516
U.S.A.
574.295.9495
www.aetechron.com

DECLARATION OF CONFORMITY

Technical Construction File Route

Issued By: AE Techron, Inc.
2507 Warren Street
Elkhart, IN 46516

For Compliance Questions Only: Larry Shank
574-295-9495
lshank@aetechron.com

This Declaration of Conformity is issued under the sole responsibility of AE Techron, Inc., and belongs to the following product:

Equipment Type: Industrial Power Amplifiers

Model Name: 7224

EMC Standards:

- EN 61326-1: 2013 – Electrical Equipment for Measurement, Control and Laboratory use
 - EMC Requirements
- EN 55011: 2009 + A1: 2010 – Industrial, Scientific and Medical (ISM) radio-frequency equipment
 - Radio disturbance characteristics
 - Limits and methods of measurement
- EN 61000-4-2: 2009 – Electromagnetic compatibility (EMC) Part 4: Testing and measurement techniques:
Electrostatic discharge immunity test
- EN 61000-4-3: 2006 + A2: 2010 – Electromagnetic compatibility (EMC) Part 4: Testing and measurement techniques:
Radiated radio-frequency electromagnetic field immunity test
- EN 61000-4-4: 2004 + A1: 2010 – Electromagnetic compatibility (EMC) Part 4: Testing and measurement techniques:
Electrical fast transient/burst immunity test
- EN 61000-4-5: 2006 – Electromagnetic compatibility (EMC) Part 4: Testing and measurement techniques:
Surge immunity test
- EN 61000-4-6: 2009 – Electromagnetic compatibility (EMC) Part 4: Testing and measurement techniques:
Immunity to conducted disturbances induced by radio frequency field
- EN 61000-4-8: 2010 – Electromagnetic compatibility (EMC) Part 4: Testing and measurement techniques:
Power frequency magnetic field immunity test

Safety Standard:

BSEN61010-1:2010 (inc Corr. May 2011) – Safety requirements for electrical equipment for measurement, control, and laboratory use

I certify that the product identified above conforms to the requirements of the EMC Council Directive 2004/108/EC (until 19th April, 2016) and Directive 2014/30/EU (from 20th April, 2016), and the Low Voltage Directive 2006/95/EC (until 19th April, 2016) and Directive 2014/35/EU (from 20th April, 2016).

Signed:

Larry Shank
President



Place of Issue: Elkhart, IN, USA
Date of Issue: March 18, 2016

CE Affixing Date: March 4, 2011

Contents

1	Introduction	6
1.1	Features	6
2	Amplifier Setup.....	7
2.1	Safety First	7
2.2	Unpacking	7
2.3	Installation	7
2.4	Connecting the Load	8
2.5	Connecting the Input Signal	8
2.6	Connecting the AC Supply	9
2.7	Start-up Procedure	10
3	Amplifier Operation	11
3.1	Front-Panel Controls	11
3.2	Front-Panel Indicators	12
3.3	Back-Panel Controls and Connectors	15
4	Advanced Configuration.....	18
4.1	Configuration Access Panel	18
4.2	Configuration Settings Located on the Main Board.....	18
4.3	Configuration Settings Located on the Power Supply Board	21
5	Applications.....	24
5.1	Remote Status and Control using the SIM Interlock I/O Connector	24
5.2	Controlled Current Operation	28
5.3	Multi-amplifier Systems	32
6	Amplifier Signal Flow.....	37
6.1	Input Signals.....	37
6.2	AC Mains Power.....	37
7	Maintenance	38
7.1	Clean Amplifier Filter and Grills	38
8	Troubleshooting	39
8.1	Introduction & Precautions	39
8.2	Visual Inspection	39
8.3	No Signal.....	40
8.4	No LEDs Illuminated or No Fans.....	40
8.5	OverVoltage LED Lit.....	40
8.6	Standby LED Remains Illuminated.....	40
8.7	Amplifier Overheats (Over Temp Fault Condition).....	41
8.8	Fault LED is Illuminated	41
8.9	Factory Service	41
9	Specifications.....	43

List of Figures

Figure 1.1 – 7224 Front Panel.....	6
Figure 2.1 – 7224 Back Panel.....	8
Figure 2.2 – Connecting the Load.....	8
Figure 2.3 – Closeup of the Output Terminals.....	8
Figure 2.4 – Closeup of SIM card.....	9
Figure 2.5 – Wiring for Unbalanced or Balanced Input Connector.....	9
Figure 2.6 – Closeup of AC Mains Outlet.....	10
Figure 2.7 – Sample of Configurations Setting Label.....	10
Figure 3.1 – Power Switch.....	11
Figure 3.2 – Gain Control.....	11
Figure 3.3 – Push Buttons.....	11
Figure 3.4 – Indicators.....	12
Figure 3.5 – Main Status Indicators for Stand-Alone Amplifiers.....	12
Figure 3.6 – Fault Status Indicators for Stand-Alone Amplifiers.....	13
Figure 3.7 – Main Status Indicators for Multi-Amplifier Systems.....	14
Figure 3.8 – Fault Status Indicators for Multi-Amplifier Systems.....	15
Figure 3.9 – Back Panel Controls and Connectors.....	17
Figure 4.1 – Access Panel Screw Locations.....	18
Figure 4.2 – Main Board Location Inside Access Panel.....	19
Figure 4.3 – Master/Slave Setting.....	19
Figure 4.4 – Gain Trim Control.....	19
Figure 4.5 – Controlled-Voltage/Controlled-Current Mode Setting.....	20
Figure 4.6 – Compensation Setting.....	20
Figure 4.7 – Run Mode/Stop Mode on Power-Up Setting.....	20
Figure 4.8 – Standby Mode on Over Temp Setting.....	21
Figure 4.9 – Standby Mode on Over Load Setting.....	21
Figure 4.11 – Location of Amplifier High-Voltage Transformer Sockets.....	22
Figure 4.10 – Accessing the Power Supply Board.....	22
Figure 4.12 – J3 and J7 Plug Locations for High-Current Output.....	22
Figure 4.13 – J4 and J8 Plug Locations for High-Voltage Output.....	22
Figure 4.14 – Bi-Level Power Switch Location.....	23
Figure 5.1 – Remote Status and Control Pinouts.....	24
Figure 5.2 – Remote Run/Standby Monitor.....	24
Figure 5.3 – Remote Status and Reset Schematic.....	25
Figure 5.4 – Remote Enable/Standby.....	26
Figure 5.5 – Remote Voltage Monitoring.....	27
Figure 5.6 – Remote Current Monitoring.....	27
Figure 5.7 – Remote Current Monitoring, Alternate Method.....	28
Figure 5.8 – Input to Output Comparison, Controlled-Voltage Operation.....	28
Figure 5.9 – Input to Output Comparison, Controlled-Current Operation.....	29
Figure 5.10 – Factory-installed Default RC Network.....	29
Figure 5.11 – Custom Compensation Location.....	31
Figure 5.12 – Compensation Effects on Waveform.....	31
Figure 5.13 – Square Wave Showing a Decrease in R is Required.....	32
Figure 5.14 – Square Wave Showing an Increase in R is Required.....	32
Figure 5.15 – Square Wave Showing an Increase in C is Required.....	32
Figure 6.1 – Board-Level Functional Block Diagram.....	37
Figure 8.1 – +Vcc and –Vcc Point Locations.....	39
Figure 8.2 – Fuse F1 Location.....	40
Figure 8.3 – Interlock I/O Connector.....	40
Figure 9.1 – Voltage Potential vs. Frequency.....	45
Figure 9.2 – Frequency Response.....	45
Figure 9.3 – Noise vs. Frequency.....	45
Figure 9.4 – Continuous Power vs. Frequency.....	45
Figure 9.5 – Thermal Performance.....	45
Figure 9.6 – DO 160 Section 18.2 AC Power Processing.....	45
Figure 9.7 – DC Current Over Time at 13.5 VDC.....	46
Figure 9.8 – DC Current Over Time, 2-ohm Load.....	46
Figure 9.9 – DC Current Over Time, 3-ohm Load.....	46
Figure 9.10 – DC Current Over Time, 4-ohm Load.....	46
Figure 9.11 – DC Current Over Time, Comparison with 4-ohm Load.....	46



Figure 1.1 – 7224 Front Panel

1 Introduction

Congratulations on your purchase of the 7224 AE Techron power amplifier—one of the most precise power amplifiers ever produced for industrial applications and testing. The 7224 amplifiers are built and tested to the most stringent quality standards for long life and outstanding performance. The AE Techron brand is known throughout the world for its robust precision amplifiers as well as its product service and support.

1.1 Features

The 7224 is a single-channel linear amplifier designed for use in demanding applications requiring low noise, low distortion, and accurate power amplification from DC to 300 kHz. They feature:

- Frequency bandwidth of DC to 300 kHz.
- Continuous output of over 1,100 watts RMS at 4 ohms.
- 40 mSec pulses of up to 52 amperes peak into a 0.5 ohm load.
- System output of over 4,000 watts or over 200 amperes maximum is possible with multiple, interconnected amplifiers.
- Efficient design and light weight chassis materials allow amplifier to occupy only 2U height, and weigh only 41 lbs.
- Robust, linear power supply results in extremely low noise; bi-level switch design limits heat dissipation to output devices.
- Protection circuitry protects the AE Techron 7224 from input overloads, improper output connection (including shorted and improper loads), over-temperature, over-current, and supply voltages that are too high or low.
- 7224 with “P” option offers precision control of output offset, DC drift and gain linearity.
- Shipped ready to operate from 120-volt ($\pm 10\%$) single-phase AC mains; 220/240-volt model available on request.

2 Amplifier Setup

The 7224 amplifiers are precision instruments that can be dangerous if not handled properly. Lethal voltages are present in both the AC input supply and the output of these amplifiers. For this reason, safety should be your primary concern when you setup and operate this amplifier.

2.1 Safety First

Throughout this manual special emphasis is placed on good safety practices. The following graphics are used to highlight certain topics that require extra precaution.



2.2 Unpacking

All amplifiers are tested and inspected for damage before leaving the factory. Carefully unpack and inspect the amplifier for damage. **Please note any damage for future reference and notify the shipping company immediately if damage is found.** Also, please save the shipping carton and materials as evidence of damage and/or for returning the amplifier for repair.

Along with any additional accessories purchased by the customer, all 7224 amplifiers ship with the following:

- 7224 Amplifier
- Toolkit (contains one #2 Phillips screwdriver and four rubber feet)
- Power Cord
- 7224 Operator's Manual and Quick Start sheet

2.3 Installation

The 7224 amplifiers are packaged in a rugged powder-coated aluminum chassis. This chassis is 2U (rack units) tall, and has rack "ears" on each side of the front panel for mounting to a standard EIA (Electronic Industries Association) rack. Use standard rack mounting hardware to mount the amplifier. Use nylon washers if you wish to protect the powder-coat finish on the front of the amplifier.

Optionally, the amplifier can be placed on a bench top; please keep in mind that the protective powder-coating can be scratched when placed on other equipment or on a bench top, especially when there is dirt present. To protect the finish, a set of rubber feet is included in the toolkit that can be installed on the bottom of the amplifier.

Allow ample space on the sides and especially the back of the amplifier for heated air to escape. The amplifier should be mounted in a rack that is adequately ventilated and not sealed. Likewise, the front of the amplifier should be unobstructed to allow cool air to enter the amplifier.

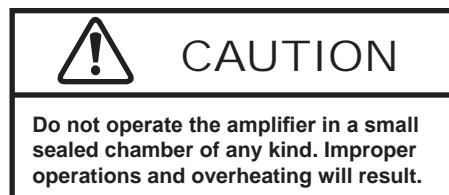





Figure 2.1 – 7224 Back Panel

2.4 Connecting the Load

Before connecting the amplifier, make sure the AC power cord is unplugged.



WARNING

ELECTRIC SHOCK HAZARD.

Output potentials can be lethal. Make connections only with AC Power OFF and input signals removed.

This section describes output wiring to the load when using the default amplifier configuration: Single (or Master) amplifier operated in Controlled Voltage mode. The 7224 amplifier also can be field-adjusted for operation in Controlled Current mode or for operation as a Slave amplifier in a multi-amplifier system. These alternate configurations may require special output wiring and/or additional components.

If your application requires Controlled Current and/or Slave operation, change the default settings on the main board before connecting the amplifier. (See the **Advanced Configuration** section for more information.)

Connection to the output of the amplifier is to a 3-position terminal strip with #8 screws. Wires terminated with #8 ring terminals, tinned wires up to 10GA in size, or bus bars with 0.18 in. (4.6 mm) holes are recommended when connecting to the output terminals. Connect the load across the terminals marked “OUTPUT” (positive) and “COM” (negative/ground). The third terminal, “CHASSIS GROUND” can be connected to an external ground point such as the rack chassis. See **Figure 2.2**.

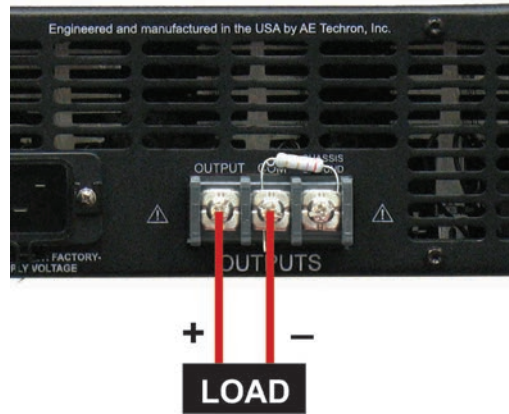

Figure 2.2 – Connecting the Load

Always use the appropriate wire size and insulation for the maximum current and voltage expected at the output. Never connect the output of the amplifier to any other model amplifier, power supply, signal source, or other inappropriate load; fire can result.

NOTE: The 7224 amplifier comes with a factory-installed 2.7-ohm, 2W, 5%, metal-oxide resistor connecting the terminals marked “COM and “CHASSIS GROUND” (see **Figure 2.3**). This resistor should NOT be removed. **WARNING: Removing this resistor can cause dangerous output and/or damage to the load.**



Figure 2.3 – Closeup of the Output Terminals

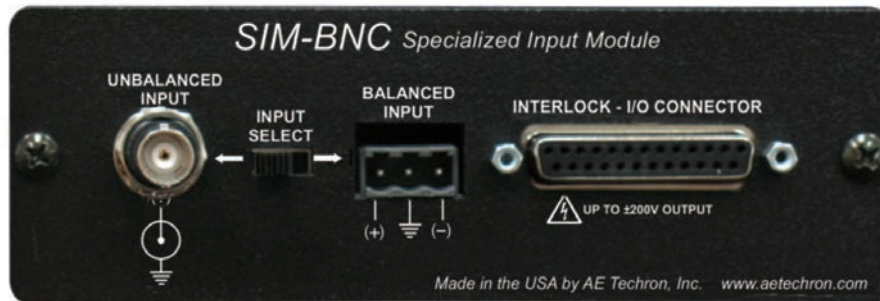

Figure 2.4 – Closeup of SIM card

2.5 Connecting the Input Signal

The signal is connected to the amplifier through a “SIM (Specialized Input Module) Card” located on the amplifier back panel (see **Figure 2.4**). The standard SIM card includes both an Unbalanced Input BNC jack and a Balanced Input “WECO” terminal block connector, an Input Select switch, and an Interlock – I/O Connector. See the **Applications** section for information on using the Interlock – I/O Connector.

Position the **Input Select** switch to the left to select the Unbalanced Input connector and to the right to select the Balanced Input connector. Note that **when the Input Select switch is in the right position, both Unbalanced and Balanced Input connectors are enabled.**

IMPORTANT: The Input Select switch also functions as a Ground Lift switch for the Unbalanced Input connector. If circulating currents/ground loops/60-Hz Hum occur when using the Unbalanced Input, move the Input Select switch to the right to lift the ground on the connector.

Connect your input signal to the amplifier’s unbalanced or balanced input connector as shown in **Figure 2.5**. Use cables that are high quality and shielded to minimize noise and to guard against possible feedback.

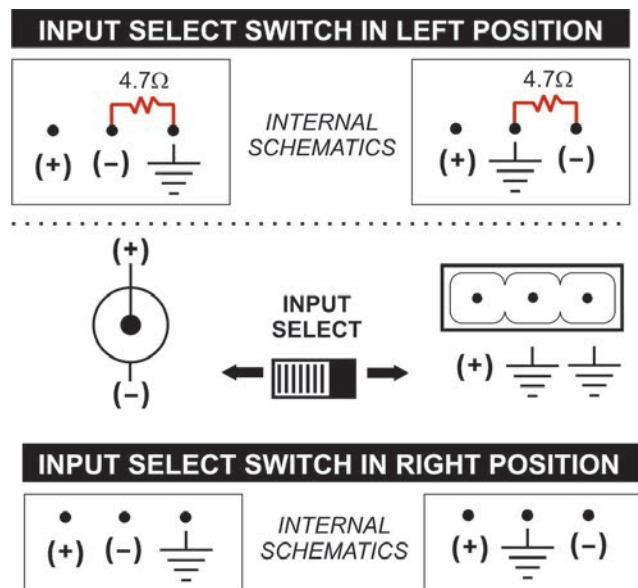

Figure 2.5 – Wiring for Unbalanced or Balanced Input Connector

2.6 Connecting the AC Supply

The power cord connects to a standard 20 amp 3-pin IEC-type male connector on the back panel (see **Figure 2.6**). Make sure the Breaker/Switch on the front panel is switched to the OFF (O) position. Make sure the power cord is inserted and seated fully into the IEC connector by moving it slightly back and forth and up and down while pushing in. The power cord is relatively stiff and should be routed so that there is no excessive force pulling to the sides or up or down that would stress the pins or internal connections. Tighten the cord strain relief screw to lock the power cord in place.

Review the factory-set supply voltage and amplifier configuration detailed on the label placed on the side of the amplifier (see **Figure 2.7**). This configuration can be changed by the user. See the **Advanced Configuration** section for more information.

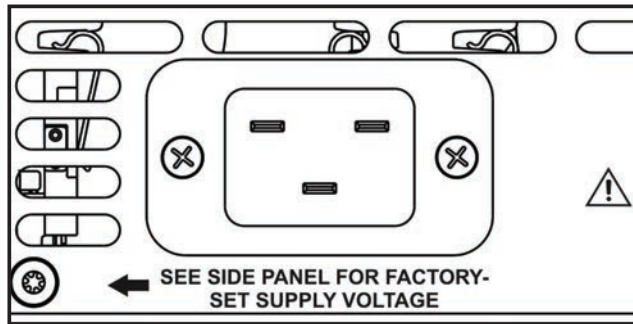

Figure 2.6 – Closeup of AC Mains Outlet

2.7 Start-up Procedure

1. Turn down the level of your signal source.
2. Turn down the gain control of the amplifier.
3. Depress the POWER switch to turn the amplifier ON.
4. Wait for the yellow READY and green RUN LEDs to illuminate.
5. Adjust the level of your input signal source to achieve the desired output level.
6. Turn up the Gain control on the amplifier until the desired voltage or power level is achieved.
7. Adjust the input signal level to achieve the desired output level.

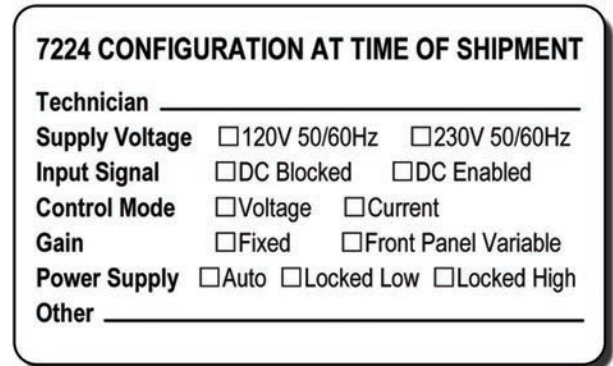

Figure 2.7 – Sample of Configurations Setting Label

3 Amplifier Operation

3.1 Front-Panel Controls

This section provides an overview of Front-Panel controls and indicators found on the 7224.

3.1.1 Power Switch

The Power Switch controls the AC mains power to the amplifier. Switch to the ON position (I) to turn the amplifier on. Switch to the OFF position (O) to turn the amplifier off. See **Figure 3.1**.

The Power Switch also serves as a Breaker. When the Breaker is tripped, the Power Switch moves to a neutral position between ON and OFF. To reset the Breaker, turn the amplifier OFF (O) and then turn it back ON (I).

3.1.2 Gain Control

The Gain Control Knob increases/decreases the gain from 0 – 100% of the overall Gain (factory default Gain is 20). See **Figure 3.2**.



Figure 3.1 – Power Switch



Figure 3.2 – Gain Control

3.1.3 Push Buttons

There are three Push Buttons on the 7224.

Enable – For stand-alone amplifiers, Enable will release the amplifier from Stop mode and place the amplifier in Run mode (both Ready and Run LEDs will be lit). When the amplifier is placed in Run mode, the amplifier will amplify the input signal. If an amplifier is disabled using a Remote Standby application, the amplifier will be placed in Standby mode (both Ready and Standby LEDs will be lit). To return the amplifier to Run mode, release the Standby condition using the remote switch. See the “Applications” section of this manual for more information on remote amplifier operation.

In multi-amp systems that have been configured to start up in Standby mode, when the Enable button is pressed on one amplifier, the amplifier will be placed in Standby mode and remain in Standby mode until all amplifiers in the system have been Enabled. The system will automatically proceed to Run mode when all amplifiers in the system achieve Standby mode.

Stop – For stand-alone amplifiers, Stop will place the amplifier in Stop mode (both Standby and Stop LEDs will be lit). When the amplifier is part of a multi-amp system, pressing the Stop button on any amplifier in the system will place that amplifier in Stop mode and all other amplifiers in the system in Standby mode. When an amplifier is in Stop or Standby mode, the low-voltage transformer is energized but the high-voltage transformers are not.

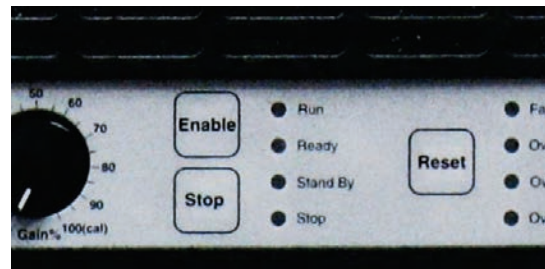

Figure 3.3 – Push Buttons

Reset – For stand-alone amplifiers, when a fault condition occurs, the amplifier may be placed in Standby mode (Standby LED will be lit), depending on the amplifier configuration and the fault condition. To release the amplifier from Standby mode, clear the fault condition and then press the Reset button. If the amplifier is in Run mode when the fault condition occurs, pressing the Reset button will return the amplifier to Run mode. If the amplifier is in Stop mode when the fault condition occurs, pressing the Reset button will return the amplifier to Stop mode.

When the amplifier is part of a multi-amp system, pressing the Reset button on the amplifier reporting the fault condition will clear the condition and return all amplifiers to Run or Stop mode; pressing the Reset button on other amplifiers in the system will NOT clear the fault condition.

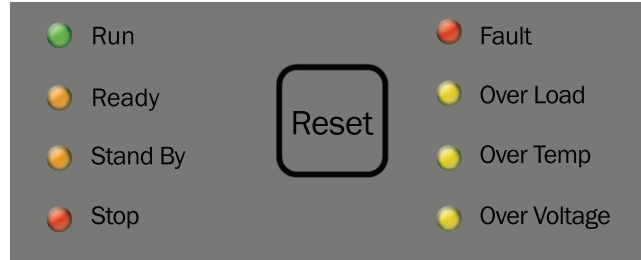

Figure 3.4 – Indicators

3.2 Front-Panel Indicators

3.2.1 Main Status Indicators

Four Main Status indicators are located on the amplifier's front-panel. These LEDs monitor the internal conditions of the amplifier and indicate the current state of operation. The chart below details the operational modes indicated by the Main Status indicators.

Figure 3.5 – Main Status Indicators for Stand-Alone Amplifiers

● ● ● ● Indicator is lit ● Indicator is not lit ○ Indicator may be lit

Main Status Indicators	State of Operation	Action Needed to Return to Run Mode
<ul style="list-style-type: none"> ● Run ● Ready ● Standby ● Stop 	<p>Run mode: The amplifier's high-voltage transformers are energized and the unit will amplify the input signal. Run mode is initiated by: (1) the Enable push button, or (2) when the amplifier powers up in Run mode (factory default). See the "Advanced Configuration" section for more information.</p>	N/A
<ul style="list-style-type: none"> ● Run ● Ready ● Standby ● Stop 	<p>Standby mode: Standby mode indicates that the amplifier is functioning properly and all Fault Status modes are clear, but it is being held in Standby by an external condition. As configured from the factory (Run mode on startup), the amplifier will enter Standby mode briefly after powering up, and then will move automatically into Run mode. In Standby mode, the amplifier's low-voltage transformer is energized but the high-voltage transformers are not.</p>	<p>If the amplifier remains in Standby mode, it is being held in Standby by remote control through the SIM Interlock I/O connector. Open the Enable/Standby switch to clear this remote Standby condition and return the amplifier to Run mode. See the "Applications" section of this manual for more information on remote amplifier operation.</p>
<ul style="list-style-type: none"> ● Run ● Ready ● Standby ● Stop 	<p>Stop mode: When the Stop button on the amplifier front panel is pressed, the amplifier will enter Stop mode. The amplifier may also enter Stop mode after powering up if the amplifier is configured to enter Stop mode on startup. In Stop mode, the amplifier's low-voltage transformer is energized but the high-voltage transformers are not.</p>	<p>To release the amplifier from Stop mode, press the Enable button.</p>

3.2.2 Fault Status Indicators

Four Fault Status indicators are located on the amplifier front panel. These LEDs monitor the internal conditions of the amplifier and will illuminate when a fault condition occurs. Depending on the

fault condition and the configuration of the unit, the amplifier may be placed in Standby mode when a fault condition occurs. Refer to the following chart to determine the fault condition being indicated and the action required to clear the fault condition.

Figure 3.6 – Fault Status Indicators for Stand-Alone Amplifiers

● ● ● ● Indicator is lit ● Indicator is not lit ○ Indicator may be lit

Main Status Indicators	Fault Status Indicators	State of Operation	Action Needed to Clear Fault Condition and Return to Run Mode
<ul style="list-style-type: none"> ● Run ● Ready ● Standby ● Stop 	<ul style="list-style-type: none"> ● Fault ● Over Load ● Over Temp ● Over Voltage 	<p>Output Fault status: This indicates that an Output Fault condition has occurred and the amplifier has been placed in Standby mode. The Fault indicator will light under two conditions: 1) High-frequency oscillation is causing high shoot-through current; or 2) An output transistor has shorted, causing the output fault condition.</p>	<p>This fault condition cannot be cleared using the front-panel Reset button. See the “Troubleshooting” section for more information on diagnosing and clearing this fault condition.</p>
<ul style="list-style-type: none"> ● Run ● Ready ○ Standby ● Stop 	<ul style="list-style-type: none"> ● Fault ● Over Load ● Over Temp ● Over Voltage 	<p>Over Load status: This indicates that the output of the amplifier could not follow the input signal due to voltage or current limits. Under normal operation with the factory-default settings, an Over Load condition will not place the amplifier in Standby mode. If the amplifier has been configured to be forced to Standby on Over Load, the amplifier will be placed in Standby mode when the Over Load indicator lights.</p>	<p>To remedy the Over Load fault during operation, turn down the level of the input signal until the Over Load indicator turns off. To clear an Over Load fault condition when the amplifier is forced to Standby, turn down the level of the input signal, then push the Reset button.</p>
<ul style="list-style-type: none"> ● Run ● Ready ● Standby ● Stop 	<ul style="list-style-type: none"> ● Fault ● Over Load ○ Over Temp ● Over Voltage 	<p>Over Temp status: The amplifier monitors the temperature inside the high-voltage transformers, low-voltage transformer and in the output stage heat sinks. The Over Temp indicator will light and the amplifier will be placed in Standby mode when the temperature sensors detect a condition that would damage the amplifier. If the Over Temp pulse is extremely short, as in the case of defective wiring or switches, the Over Temp LED may be lit too briefly to observe.</p>	<p>To reset after an Over Temp fault has occurred, make sure the fans are running, and then remove the input signal from the amplifier. Allow the fans to run for about 5 minutes until the amplifier automatically returns to Run mode. If the amplifier has been configured for Standby mode on Over Temp, then the amplifier will not automatically return to Run mode. In that case, push the Reset button to return the amplifier to Run mode. See the “Troubleshooting” section for information on correcting the cause of an Over Temp fault condition.</p>
<ul style="list-style-type: none"> ● Run ● Ready ● Standby ● Stop 	<ul style="list-style-type: none"> ● Fault ● Over Load ● Over Temp ● Over Voltage 	<p>Over Voltage status: This indicates that the AC mains voltage is more than +10% of nominal. The amplifier will be forced to Standby when an Over Voltage condition occurs. When the Over Voltage condition is cleared, the amplifier will automatically return to Run mode.</p>	<p>To clear an Over Voltage fault condition, the AC mains must be brought down to the nominal value. If the amplifier does not return to Run mode when the Over Voltage condition has cleared, the amplifier may require servicing. Please see the “Troubleshooting” section for more information.</p>

3.2.3 Main Status Indicators for **Multi-amplifier Systems**

The Main Status indicators on each amplifier in a multi-amp system are used to determine the

operational status of the amplifier. When evaluated along with the statuses of other amplifiers in the system, the Main Status indicators can be used to determine the system status and the action required to return the system to Run mode.

Figure 3.7 – Main Status Indicators for Multi-Amplifier Systems

● ● ● ● Indicator is lit ● Indicator is not lit ○ Indicator may be lit

Main Status of One or More Amps in the System	Main Status of Other Amps in the System	State of Operation	Action Needed to Return to Run Mode
<ul style="list-style-type: none"> ● Run ● Ready ● Standby ● Stop 	<ul style="list-style-type: none"> ● Run ● Ready ● Standby ● Stop 	Run mode: All of the amplifiers in the system are in Run mode. The amplifiers' high-voltage transformers are energized and the system will amplify the input signal.	N/A
<ul style="list-style-type: none"> ● Run ● Ready ● Standby ● Stop 	<ul style="list-style-type: none"> ● Run ● Ready ● Standby ● Stop 	Remote Standby Condition: All of the amplifiers in the system are being held in Standby mode by an external condition. In Standby mode, the amplifiers' low-voltage transformers are energized but the high-voltage transformers are not.	If the amplifiers remain in Standby mode, the system is being held in Standby by remote control through the SIM Interlock I/O connector. Open the Enable/Standby switch to clear this remote Standby condition and return the system to Run mode. See the "Applications" section of this manual for more information on remote amplifier operation.
<ul style="list-style-type: none"> ● Run ● Ready ● Standby ● Stop 	<ul style="list-style-type: none"> ● Run ● Ready ● Standby ● Stop 	System Not Ready: If one or more of the amplifiers has no LEDs lit, the amplifier has no power or has not been turned on, and the other amplifiers in the system will be held in Standby mode. In Standby mode, the amplifier's low-voltage transformer is energized but the high-voltage transformers are not.	Make sure all amplifiers have AC power and have been turned on. When all amplifiers attain Standby status, all amplifiers in the system will simultaneously be placed in Run mode.
<ul style="list-style-type: none"> ● Run ● Ready ● Standby ● Stop 	<ul style="list-style-type: none"> ● Run ● Ready ● Standby ● Stop 	Stop mode: When the Stop button on any amplifier in the system is pressed, that amplifier will enter Stop mode and all other amplifiers will enter Standby mode. The system may also enter Stop mode after powering up if one or more amplifiers in the system is configured to enter Stop mode on startup. In Stop mode, the amplifier's low-voltage transformer is energized but the high-voltage transformers are not.	To release the system from Stop mode, press the Enable button on the amplifier displaying the Stop mode status.

3.2.4 Fault Status Indicators for Multi-Amp Systems

The four Fault Status indicators located on each amplifier's front panel are used to monitor the internal conditions of the amplifier and will illuminate when a fault condition occurs. All amplifiers in the system may be placed in Standby mode when a fault condition occurs, depending on the

fault condition and the configuration of the system. Typically, the system can be released from Standby mode by pressing the Reset button on the amplifier displaying the Fault status. Refer to the chart below to determine the fault condition being indicated and the action required to clear the fault condition and return the system to Run mode.

Figure 3.8 – Fault Status Indicators for Multi-Amplifier Systems

● ● ● ● Indicator is lit ● Indicator is not lit ○ Indicator may be lit

One or More Amps in System		Other Amps in System		State of Operation	Action Needed to Clear Fault Condition and Return to Run Mode
Main Status Indicators	Fault Status Indicators	Main Status Indicators	Fault Status Indicators		
<ul style="list-style-type: none"> ● Run ● Ready ● Standby ● Stop 	<ul style="list-style-type: none"> ● Fault ● Over Load ● Over Temp ● Over Voltage 	<ul style="list-style-type: none"> ● Run ● Ready ● Standby ● Stop 	<ul style="list-style-type: none"> ● Fault ● Over Load ● Over Temp ● Over Voltage 	<p>Output Fault status: This indicates that an Output Fault condition has occurred in the amplifier displaying the Fault status, and the system has been placed in Standby mode. The Fault indicator will light under two conditions: 1) High-frequency oscillation is causing high shoot-through current; or 2) An output transistor has shorted, causing the output fault condition.</p>	<p>This fault condition cannot be cleared using the front-panel Reset button. See the “Troubleshooting” section for more information on diagnosing and clearing this fault condition.</p>
<ul style="list-style-type: none"> ● Run ● Ready ○ Standby ● Stop 	<ul style="list-style-type: none"> ● Fault ● Over Load ● Over Temp ● Over Voltage 	<ul style="list-style-type: none"> ● Run ○ Ready ○ Standby ● Stop 	<ul style="list-style-type: none"> ● Fault ● Over Load ● Over Temp ● Over Voltage 	<p>Over Load status: This indicates that the output of the system could not follow the input signal due to voltage or current limits. Under normal operation with the factory-default settings, an Over Load condition will not place the system in Standby mode. If the system has been configured to be forced to Standby on Over Load, the system will be placed in Standby mode when the Over Load indicator lights.</p>	<p>To remedy the Over Load fault during operation, turn down the level of the input signal until the Over Load indicator turns off. To clear an Over Load fault condition when the amplifier is forced to Standby, turn down the level of the input signal, then push the Reset button on the amplifier(s) displaying the Over Load status.</p>

One or More Amps in System		Other Amps in System		State of Operation	Action Needed to Clear Fault Condition and Return to Run Mode
Main Status Indicators	Fault Status Indicators	Main Status Indicators	Fault Status Indicators		
<ul style="list-style-type: none"> ● Run ● Ready ● Standby ● Stop 	<ul style="list-style-type: none"> ● Fault ● Over Load ○ Over Temp ● Over Voltage 	<ul style="list-style-type: none"> ● Run ● Ready ● Standby ● Stop 	<ul style="list-style-type: none"> ● Fault ● Over Load ● Over Temp ● Over Voltage 	<p>Over Temp status: Each amplifier in the system monitors the temperature inside the high-voltage transformers, low-voltage transformer and in the output stage heat sinks. The Over Temp indicator will light and the system will be placed in Standby mode when the temperature sensors detect a condition that would damage the amplifier system. If the Over Temp pulse is extremely short, as in the case of defective wiring or switches, the Over Temp LED may be lit too briefly to observe.</p>	<p>To reset after an Over Temp fault has occurred, make sure the amplifier fans in all amplifiers are running, and then remove the input signal from the system. Allow the fans to run for about 5 minutes until the system automatically returns to Run mode. If the system has been configured for Standby mode on Over Temp, then the system will not automatically return to Run mode. In that case, push and hold the Reset button on any amplifier displaying the Over Temp status until the Standby LED turns off, then release the Reset button to return the system to Run mode. Please see the “Troubleshooting” section for information on correcting the cause of an Over Temp fault condition.</p>
<ul style="list-style-type: none"> ● Run ● Ready ● Standby ● Stop 	<ul style="list-style-type: none"> ● Fault ● Over Load ● Over Temp ● Over Voltage 	<ul style="list-style-type: none"> ● Run ● Ready ● Standby ● Stop 	<ul style="list-style-type: none"> ● Fault ● Over Load ● Over Temp ● Over Voltage 	<p>Over Voltage status: This indicates that the AC mains voltage is more than +10% of nominal. All amplifiers in the system will be forced to Standby when an Over Voltage condition occurs. When the Over Voltage condition is cleared, the system will automatically return to Run mode.</p>	<p>To clear an Over Voltage fault condition, the AC mains must be brought down to the nominal value. If the system does not return to Run mode when the Over Voltage condition has cleared, one or more amplifiers may require servicing. Please see the “Troubleshooting” section for more information.</p>

3.3 Back-Panel Controls and Connectors

This section provides an overview of Back-Panel controls and connectors found on the 7224. Please refer to **Figure 3.5** for visual locations.

AC Supply – Standard 20 amp 3-pin IEC-type male connector.

Output Terminal Strip – Connect output lines from the load to this 3-position terminal strip with #8 screws. It accepts up to #10 AWG wire.

Unbalanced BNC Input Connector – This input option provides a standard unbalanced input.

Input Selector Switch – When in the LEFT position, the unbalanced BNC input connector is enabled. When in the RIGHT position, both unbal-

anced BNC and balanced Phoenix® input connectors are enabled. The Input Select switch also functions as a Ground Lift switch for the Unbalanced BNC input connector. If circulating currents/ground loops/60-Hz Hum occur when using the unbalanced input, move the Input Select switch to the right to lift the ground on the connector.

Balanced Phoenix® Input Connector – This input option provides a balanced input.

Interlock Connector – This 25-pin, D-sub connector is used for interlocking and combining functions in a system of multiple amplifiers. It can also be used for remote control and monitoring applications (see the “**Applications**” section for more information).

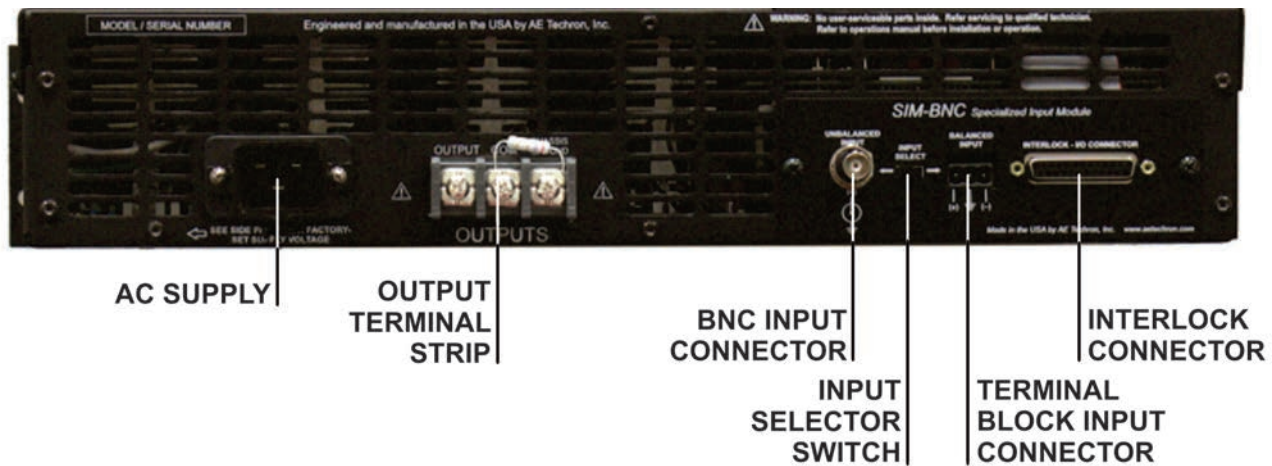

Figure 3.9 – Back Panel Controls and Connectors

4 Advanced Configuration

The 7224 amplifier was designed to offer exceptional versatility in operation. You can choose from a range of field-configurable options, including:

- Operate as a stand-alone amplifier or as part of a multiple-amplifier system.
- Operate with variable gain control or at a fixed gain setting of 20.
- Select Controlled-Current or Controlled-Voltage modes of operation.
- Trigger Standby mode when specified overload conditions occur during operation.
- Select the Stop mode state at power-up, or go immediately to the Run mode state at power-up.
- Configure for use in high voltage applications, high current applications, or for applications requiring mid-level amounts of both voltage and current.

Your 7224 amplifier has been pre-configured to your specifications before shipping from the factory. These initial settings are detailed on your 7224 Proof of Performance sheet and on a label located on the side of the amplifier.

If you need to make changes to your amplifier's configuration, please follow the instructions contained in this chapter.

4.1 Configuration Access Panel

The 7224 amplifier contains an Access Panel built into the top cover. Most configuration settings can be made through this Access Panel. For your convenience, a #2 Phillips screwdriver is provided in your Toolkit for use in this procedure.

IMPORTANT: Before removing the Access Panel, make sure the amplifier is turned off for at least 3-5 minutes and the AC mains are disconnected.

1. Locate the Access Panel as shown in **Figure 4.1**. Make sure that all 8 screws are accessible. Remove the unit from its rack, if necessary.
2. Using a #2 Phillips screwdriver (provided), remove the 8 screws located on the top and side of the amplifier.
3. Remove the Access Panel and set it aside.

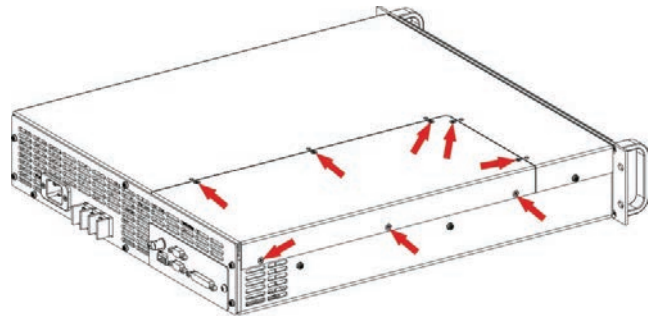

Figure 4.1 – Access Panel Screw Locations

	WARNING
Do not attempt to access the Main Board or Power Supply Board while the amplifier is running. Turn the amplifier off and disconnect the AC Mains before opening the Access Panel.	

	CAUTION
After turning the amplifier off, let the unit sit for 2 minutes before removing the Access Panel. This will allow the electrical charge in the Power Supply capacitors to discharge.	

4.2 Configuration Settings Located on the Main Board

The following custom settings can be made via jumper settings on the Main Board, which is located inside the Access Panel compartment, as shown in **Figure 4.2**.

- Master/Slave setting for stand-alone or multiple-amplifier systems.
- Variable or Fixed Gain setting.
- Controlled Current/Controlled Voltage setting.

- Compensation setting to select RC network when operating in Controlled Current mode.
- Stop Mode/Run Mode setting for selection of power-up state.
- Standby mode on Over Load setting to trigger Standby mode when amplifier senses an Over Load state.

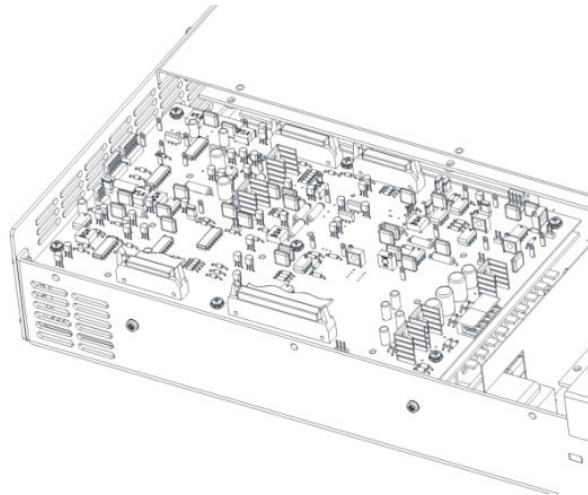

Figure 4.2 – Main Board Location Inside Access Panel

4.2.1 Master/Slave Setting

To enable the 7224 amplifier for use as a single amplifier or as the Master amplifier in a multi-amplifier system, set jumpers **P1** and **P2** in the **Master** position (jumpers across top two pins of each set). To enable the 7224 amplifier for use as a Slave amplifier in a multi-amplifier system, set jumpers **P1** and **P2** in the **Slave** position (jumpers across bottom two pins of each set). See **Figure 4.3**.

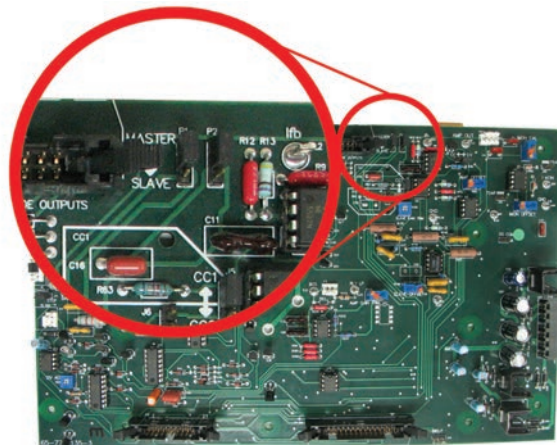

Figure 4.3 – Master/Slave Setting

4.2.2 Fixed Gain/Variable Gain Setting

The 7224 amplifier ships with an enabled Gain Control knob (located on the amplifier front panel). To disable the **Variable Gain** control and set for a **Fixed Gain of 20**, locate and unplug the red connector from jumper **J10**. Then place a **jumper on the left two pins** at that location. See **Figure 4.4**.

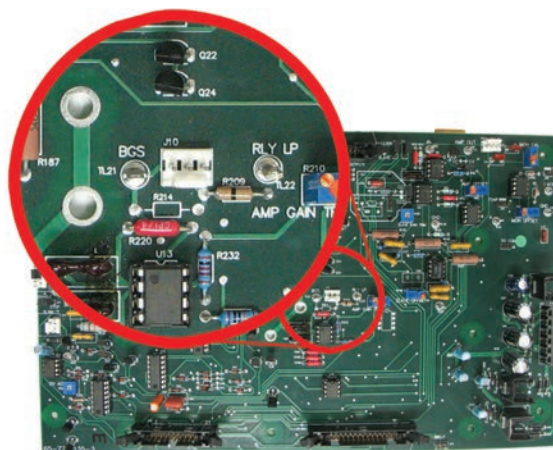

Figure 4.4 – Gain Trim Control

 **CAUTION**

In Controlled-Current Mode, the load is part of the amplifier circuit, and the relationship of the load to the amplifier is critical. For proper and safe operation in Controlled-Current mode, you must observe the following guidelines:

1. **Properly attach a load before operating the amplifier.**
2. **DO NOT use a blocking capacitor.** The load must have a DC path.

3. **Never leave the load open.** If you feel the load must be fused, which could lead to a potential open circuit, please contact AE Techron Application Engineering department.
4. **Check to make sure the load has some inductive component.**
5. **Provide appropriate Compensation for the load.**
6. **If oscillation occurs, turn of the amplifier immediately.**

Failure to follow these guidelines may result in damage to the amplifier or load.

4.2.3 Controlled-Voltage/
Controlled-Current Mode Setting

To allow the 7224 amplifier's output voltage to be controlled by its input voltage signal, place jumper **J4** in the **Right** position. To allow the 7224 amplifier's output current to be controlled by its input voltage signal, place jumper **J4** in the **Left** position. See **Figure 4.5**. For more information on Controlled-Current operation, see the “**Applications**” section of this manual.

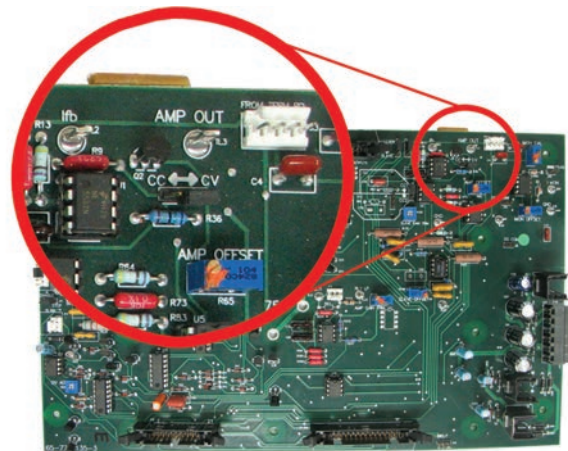

Figure 4.5 – Controlled-Voltage/
Controlled-Current Mode Setting

4.2.4 Compensation Setting
(Controlled-Current Mode)

When the 7224 amplifier is used in Controlled-Current mode, the current control loop is tuned with one of two available RC networks. Place jumper **J5** in the **Up** position to select **CC1** network. Place jumper **J5** in the **Down** position to select **CC2** network. See **Figure 4.6**. For more information on Controlled-Current operation, see the “**Applications**” section of this manual.

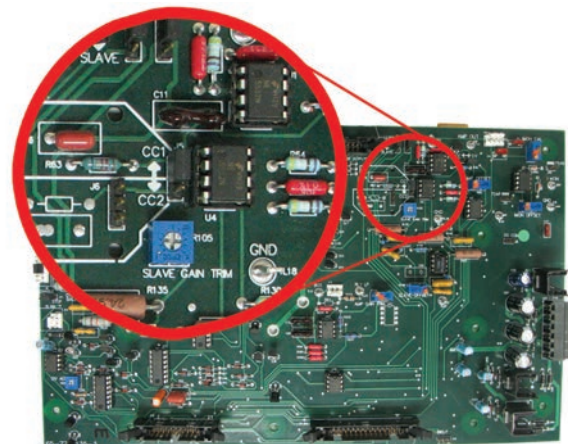

Figure 4.6 – Compensation Setting

4.2.5 Run Mode/Stop Mode on Power-Up Setting

The 7224 amplifier will power-up to **Run Mode** when jumper **J11** is in the **Left** position (default setting). To cause the 7224 amplifier to enter **Stop Mode** on power-up, place jumper **J11** in the **Right** position. See **Figure 4.7**.

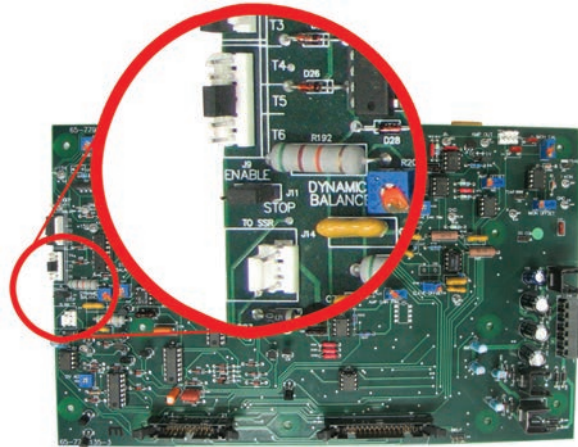

Figure 4.7 – Run Mode/Stop Mode on Power-Up Setting

4.2.6 Standby Mode on Over Load Setting

When enabled, the 7224 amplifier will move into Standby mode when it senses an activation of the IOC (Input/Output Comparator) Distortion Alert circuit. The IOC Distortion Alert circuit continuously compares the input waveform to the output waveform. When a distortion of more than 0.5% occurs, the IOC circuit will activate. The amplifier will remain in Standby Mode until the Reset switch on the front panel is pushed or a Reset signal is received on the Interlock – I/O Connector. Once reset, the amplifier will return to Run mode. To enable **Standby mode on Over Load**, place the jumper across the two pins labeled **J13**. See **Figure 4.9**.

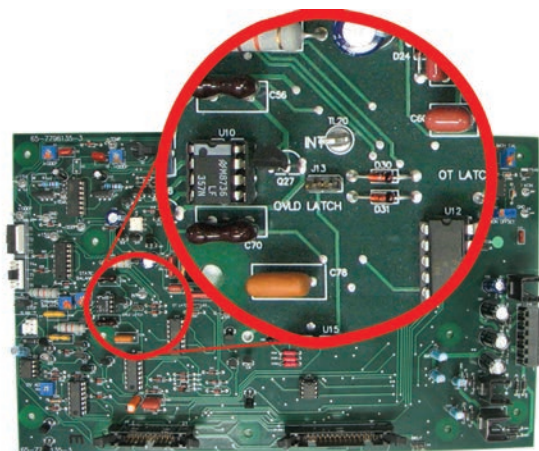

Figure 4.9 – Standby Mode on Over Load Setting

4.3 Configuration Settings Located on the Power Supply Board

The following custom settings can be made via plug-in connectors located on the Power Supply Board:

- Amplifier Voltage Potential setting (high current or high voltage)
- Bi-Level Power Supply setting

4.3.1 Selecting the Best Voltage Potential and Bi-Level Power Switch Settings for Your Application

The output of the amplifier will be determined by the combination of settings used for both Voltage Potential and Bi-Level Power Switch.

OUTPUT VOLTAGE		
Bi-Level Switch Setting	Voltage Potential Setting	
		90
Auto	45-90	90-180
High	90	180
Low	45	90

Use the following general guidelines to select the best combination of settings to fit your requirements:

OUTPUT	LOAD		Settings
	Continuous	Pulse	
High Voltage	16, 8 ohm	16, 8, 4 ohm	180 V
		Auto	
Mid-Level	4, 2 ohm	2, 1 ohm	90 V
		Auto	
High Current	1, 0.5 ohm	0.75 - 0.25 ohm	90 V
		Low	

Also see the “**Specifications**” section for more information.

4.3.2 Accessing the Power Supply Board

To access the Power Supply Board, follow the instructions given at the beginning of this Section to open the Configuration Access Panel. The Power Supply Board is located to the right of the Main Board, as shown in **Figure 4.10**.

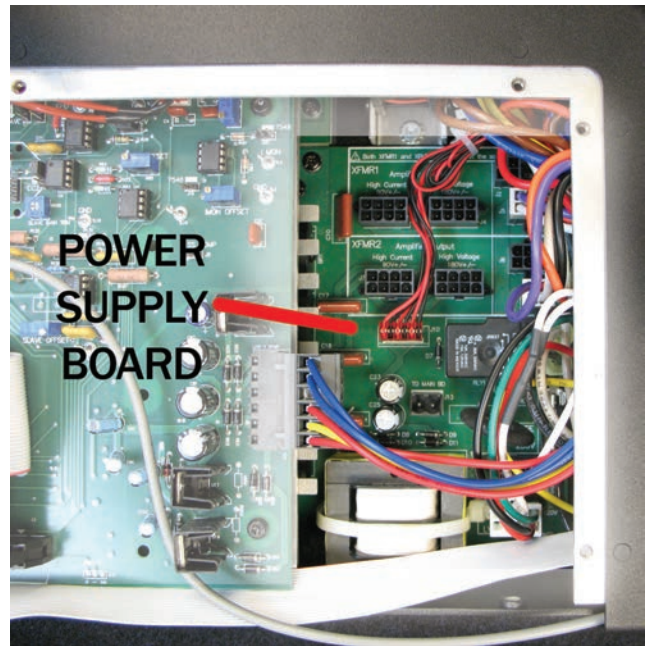

Figure 4.10 – Accessing the Power Supply Board

4.3.3 **Changing Amplifier Voltage Potential**

The 7224 can be configured for High Current (90V) or High Voltage (180V) operation via user-selectable plugs on the Power Supply Board. Complete the following steps to change the amplifier voltage potential.

1. Locate the two XFMR sections (left of Line Voltage sections) (see **Figure 4.11**).
2. For High Current (90V) Output (see **Figure 4.12**).
3. For High Voltage (180V) Output (see **Figure 4.13**).

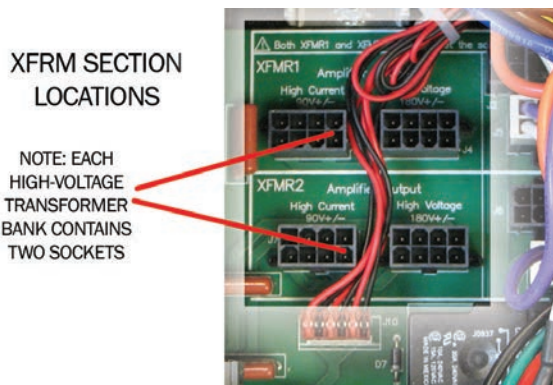

Figure 4.11 – Location of Amplifier High-Voltage Transformer Sockets

HIGH-CURRENT (90V) OUTPUT

- INSERT PLUG OF FIRST TRANSFORMER INTO J3 SOCKET
- INSERT PLUG OF SECOND TRANSFORMER INTO J7 SOCKET

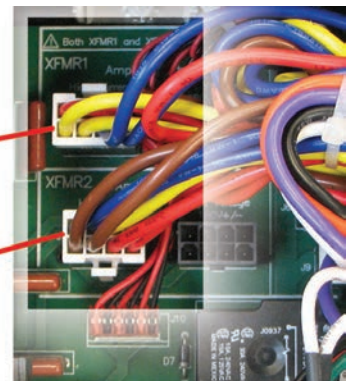

Figure 4.12 – J3 and J7 Plug Locations for High-Current Output

HIGH-VOLTAGE (180V) OUTPUT

- INSERT PLUG OF FIRST TRANSFORMER INTO J4 SOCKET
- INSERT PLUG OF SECOND TRANSFORMER INTO J8 SOCKET

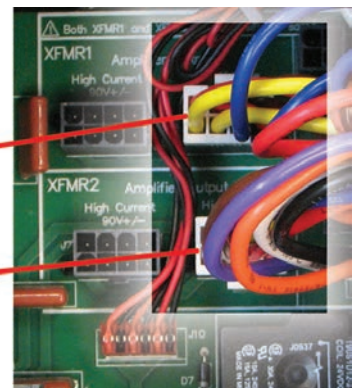

Figure 4.13 – J4 and J8 Plug Locations for High-Voltage Output

4.3.4 Changing Bi-Level Power Supply Function

The 7224 offers three Bi-Level switch settings: Automatic, High, or Low. The user can select between settings via a switch on the Power Supply Board.

To access and change the Bi-Level Power Switch, follow these steps:

1. Locate the SIM Input Card on the right side of the rear panel of the amplifier.
2. Using a #2 Phillips screwdriver (provided), remove the 2 screws located at the edges of the SIM card.
3. Keeping the ribbon cable attached, remove the SIM card from the amplifier until it is completely clear from the card bay.
4. Locate Bi-Level Power Switch, S1, a black, three-position switch at the rear of the card bay. (See **Figure 4.14**)
5. Move Black switch to desired setting. If necessary, use a pointed, non-metallic object (such as a pen) to help in moving the switch.
 - a. Automatic – Left
 - b. Low – Middle
 - c. High – Right

4.3.5 Selecting the Best Voltage Potential and Bi-Level Power Switch Settings for Your Application

The output of the amplifier will be determined by the combination of settings used for both Voltage



Figure 4.14 – Bi-Level Power Switch Location

Potential and Bi-Level Power Switch.

OUTPUT VOLTAGE

BI-LEVEL SWITCH SETTING	VOLTAGE POTENTIAL SETTING	
	High Current (90V)	High Voltage (180V)
AUTO	45 - 90	90 - 180
HIGH	90	180
LOW	45	90

Also see the **“Specifications”** section for more information.

5 Applications

5.1 Remote Status and Control using the SIM Interlock I/O Connector

The procedures outlined in this section assume competence on the part of the reader in terms of amplifier systems, electronic components, and good electronic safety and working practices.

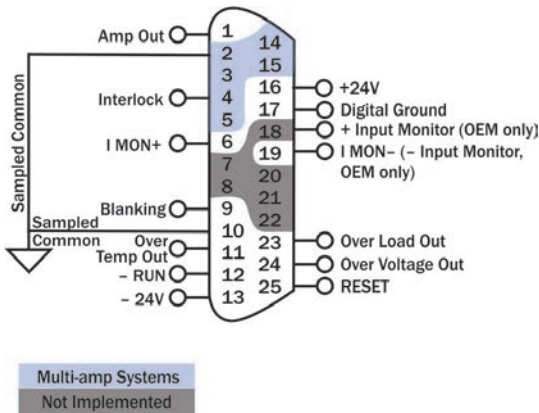

Figure 5.1 – Remote Status and Control Pinouts

AE Techron 7224 amplifiers come with a SIM-BNC input module that also contains a female, 25-pin D-Sub connector. This connector can be used to provide remote control and monitoring of the amplifier.

The information provided here will instruct you in the wiring of several control and status applications including:

- Remote Enable / Standby
- Over-temperature status
- Run status
- Overload status
- Overvoltage status
- Reset after Overload error
- Voltage monitor
- Current monitor

Figure 5.1 maps the pins used for these applications.

For a detailed chart of all DB-25 pinouts, see **“Appendix 1.”**

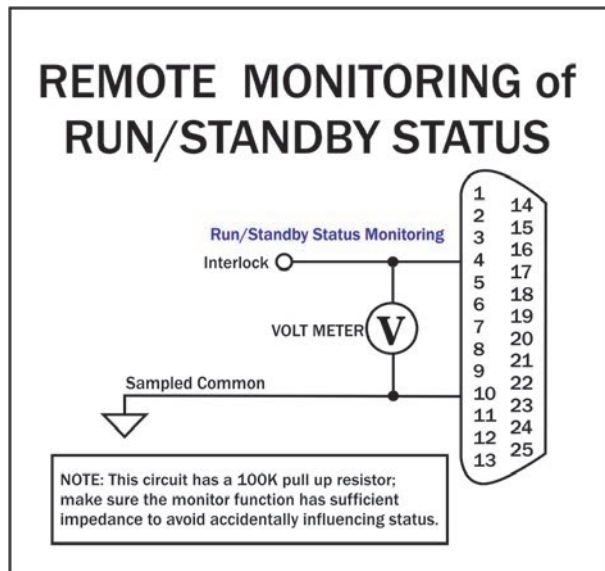

Figure 5.2 – Remote Run/Standby Monitor

5.1.1 Remote Run/Standby Status Monitor

Using the SIM-BNC Interlock connector located on the back panel of the amplifier, you can remotely monitor the Run/Standby status of the amplifier.

Remote Run/Standby Status

Purpose: Use a voltage meter to monitor the status of the amplifier to determine if the amplifier is in a “Run” or “Standby” state.

Method: Connect a voltage meter to monitor the circuit voltage. Connect across PIN 4 (Interlock) and PIN 10 (Sampled Common).

When the voltage meter reads greater than 10V, the amplifier is in the Run state; when the meter reads less than 10V, the amplifier is in the Standby state. See **Figure 5.2**.

Signal Type: DC

Level when Asserted: >10 V

Level when Deasserted: <10 V

IMPORTANT: This circuit has a 100K pull-up resistor. Make sure the monitor function has sufficient impedance to avoid accidentally influencing status.

5.1.2 **Remote Amplifier Status and Reset**

The SIM Interlock I/O Connector can be used to create a circuit to monitor remotely one or more amplifier conditions, including Run status, Over-temperature, Overload and Overvoltage. The circuit can also be constructed to allow remote reset of the amplifier when it is forced to Standby due to Over-load conditions.

Use a male, 25-pin D-Sub connector and high-quality wire to build the circuit. **Figure 5.3** schematic details the circuit and components required for all status and reset functions.

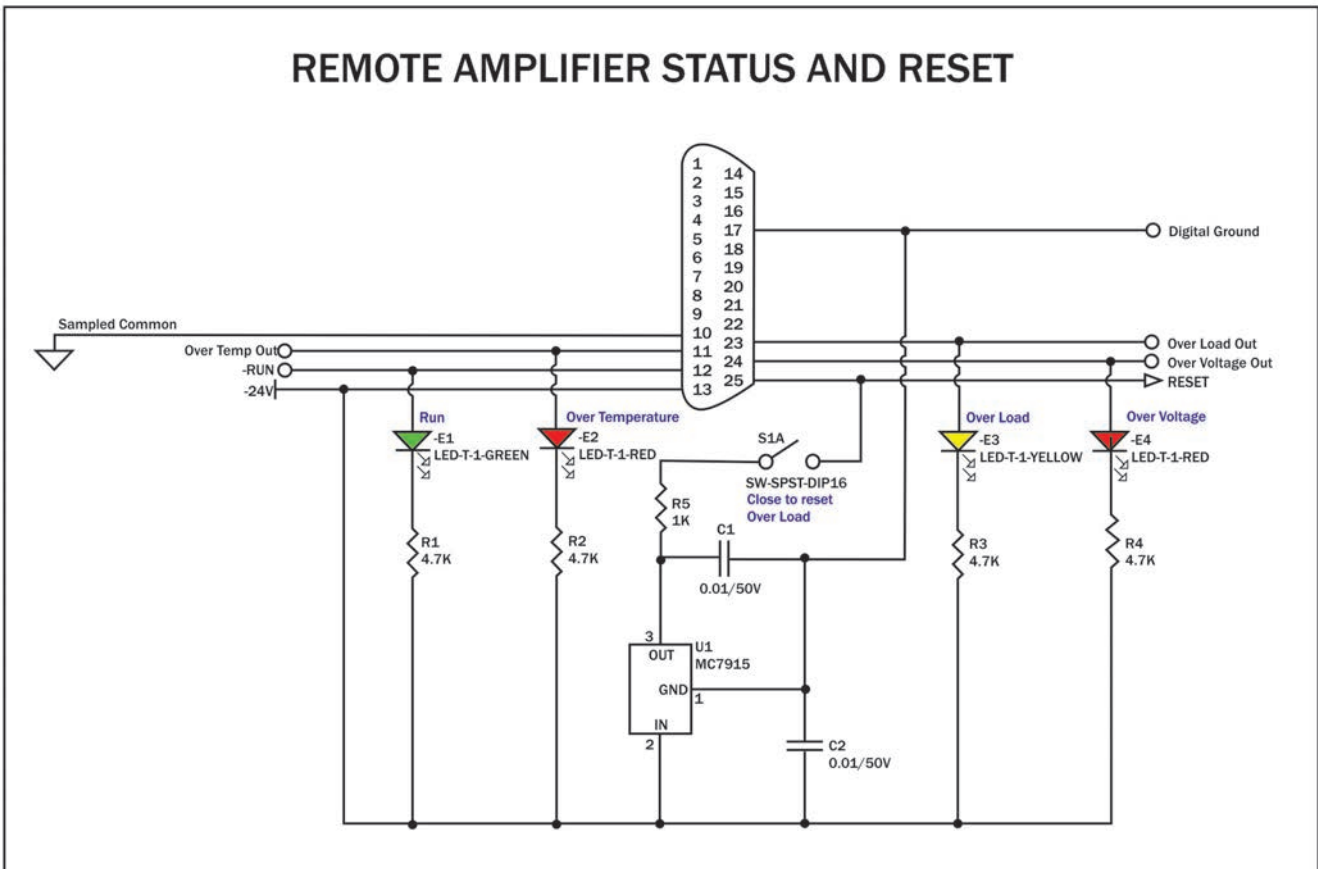

Figure 5.3 – Remote Status and Reset Schematic

Remote Signal of Over Temperature Condition

Purpose: LED, when lit, signals Over Temperature condition.

Method: Use a 6mA series resistor of 4.02 Kohm for LED or OPTO, tie OverTemp Out (PIN 11) to -24V source (PIN 13).

Signal Type: DC

Level when Asserted: -24V

Level when Deasserted: 0V

Note: When amp is normal, this pin is pulled to -24V through a 47.5K-ohm resistor; when amp is in OverTemp state, transistor Q37 turns on and sources chassis ground as an output. Do not exceed 20 milliamps.

An OverTemp condition will force the amp to Standby. The amplifier will automatically move to Run when temperature cools to operating levels.

Remote Signal of Run Condition

Purpose: LED, when lit, signals Run state.

Method: Use a 6mA series resistor of 4.02K-ohm for LED or OPTO, tie Run (PIN 12) to –24V source (PIN 13).

Signal Type: DC

Level when Asserted: –24V

Level when Deasserted: 0V

Remote Signal of OverLoad Condition

Purpose: LED, when lit, signals Overload condition.

Method: Use a 6mA series resistor of 4.02K-ohm for LED or OPTO, tie OverLoad Out (PIN 23) to –24V source (PIN 13).

Signal Type: DC

Level when Asserted: –24V

Level when Deasserted: 0V

Note: When amp is normal, this pin is pulled to –24V through a 47.5K-ohm resistor; when amp is in Overload state, transistor Q36 turns on and sources chassis ground as an output. Do not exceed 20 milliamps.

An Over Load condition will not place the amplifier in Standby when operating with the factory default settings. In order to clear the fault condition, reduce the input levels until the Over Load LED turns off. However, if the Standby Mode on Over Load option is set, an Over Load condition will force amp to Standby. To return the amplifier to Run mode, reduce the input signal level, then trigger a Reset command using the front-panel Reset button or a remote amplifier Reset command.

Remote Signal of OverVoltage Condition

Purpose: LED, when lit, signals Overvoltage condition.

Method: Use a 6mA series resistor of 4.02K-ohm for LED or OPTO, tie OverVoltage Out (PIN 24) to –24V source (PIN 13).

Signal Type: DC

Level when Asserted: –24V

Level when Deasserted: 0V

Note: When amp is normal, this pin is pulled to –24V through a 47.5K-ohm resistor; when amp is in Overvoltage state, transistor Q29 turns on and sources chassis ground as an output. Do not exceed 20 milliamps.

Reset from Standby

Purpose: Switch, when thrown, returns amp to Run condition after an Overload condition.

Method: Use a dry-contact switch, voltage regulator (MC7915), and two 0.01/50V capacitors; wire the circuit as shown (above). Assert 15V for at least 100 ms to clear the error condition.

Signal Type: DC

Level when Asserted: –15V

Level when Deasserted: 0V

Note: Tie to PIN 13 (–24V dc) and create a –15V dc source; <2mA required for reset. Connect the –15V dc source to PIN 25 (Reset) through a 1K buffer resistor to reset.

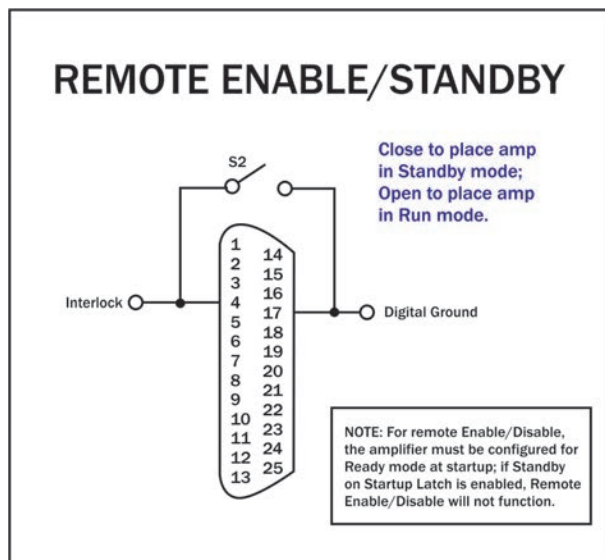

Figure 5.4 – Remote Enable/Standby

5.1.3 Remote Enable/Standby

Using the SIM-BNC Interlock connector located on the back panel of the amplifier, you can remotely Enable the amplifier and/or place the unit in Standby mode. See **Figure 5.4**.

Remote Enable/Standby

Purpose: Use a switch or optocoupler to remotely disable the amplifier and place it in Standby mode. Also, return the amplifier from Standby mode to the Run condition.

Method: Short PIN 4 of amplifier to Digital Ground (PIN 17) using a dry contact switch or optocoupler. In multi-amp applications, a switch can be used for Parallel systems, but an optocoupler must be used for Series systems. Multiple amplifiers (sharing the same Sampled Common power connections) can be simultaneously forced to Standby by daisy-

chaining Interlock (PIN 4) across amps.
 When Interlock (PIN 4) is shorted to Digital Ground (PIN 17), amplifier is placed in Standby mode.
 When switch is open, amplifier is released to the Run condition.

Signal Type: DC

Level when Asserted: 0 to 8 V

Level when Deasserted: 10 to 15 V

IMPORTANT: The amplifier must be configured for Ready mode at startup (factory default) or the Run button must be pressed at the amplifier front panel at startup. The Remote Enable/Standby circuit will not function if the Startup to Standby Latch has been activated on the amplifier.

5.1.4 Remote Monitoring of Voltage and Current

Using the SIM-BNC Interlock connector located on the back panel of the amplifier, you can remotely monitor both voltage and current output.

Use a male, 25-pin D-Sub connector and high-quality wire to build the desired circuits.

Remote Monitoring of Voltage Output

Purpose: Use a voltage meter to monitor output voltage.

Method: Connect a voltage meter to monitor the output voltage being produced by the amplifier. Connect across PIN 1 (Amp Out) and PIN 10 (Sampled Common). See **Figure 5.5**.

Signal Type: AC or DC

Level when Asserted: Can be greater than +/-200Vpeak

Level when Deasserted: 0V

Note: Used for monitoring amplifier output voltage; driving slave amplifiers in multi-amp systems. Wired to amplifier output. Do not connect to any im-

pedance of less than 10K ohm. High voltage output possible. Use appropriate safety precautions.

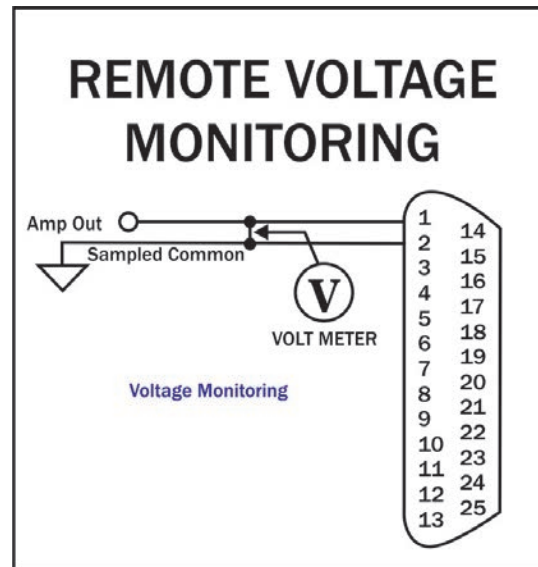

Figure 5.5 – Remote Voltage Monitoring

Remote Monitoring of Current Output

Purpose: Use a voltage meter to monitor output current.

Method: Connect a voltage meter to monitor the output current being produced by the amplifier. Connect across PIN 6 (I MON+) and PIN 10 (Sampled Common). See **Figure 5.6**.

Signal Type: DC

Level when Asserted: 7212/7224: 5A/V; /7796: 20A/V

Level when Deasserted: 0V

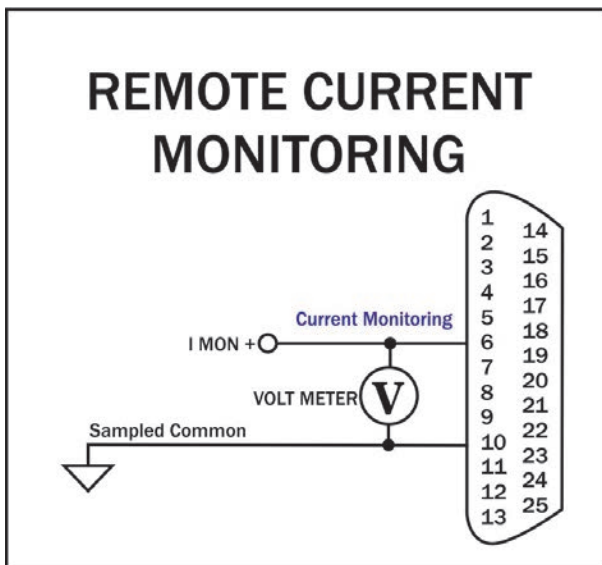

Figure 5.6 – Remote Current Monitoring

Remote Monitoring of Current Output - Alternate Method

Purpose: Use a voltage meter to monitor output current when output is not balanced.

Method: Connect a voltage meter to monitor the output current being produced by the amplifier. Connect across PIN 6 (IMON+) and PIN 19 (IMON-). See **Figure 5.7**.

Signal Type: AC

Level when Asserted: 7212/7224: 2.5A/V;
7548/7796: 10A/V

Level when Deasserted: 0V

CAUTION: To avoid ground loops, isolation from ground must be provided. Use of a differential probe is recommended.

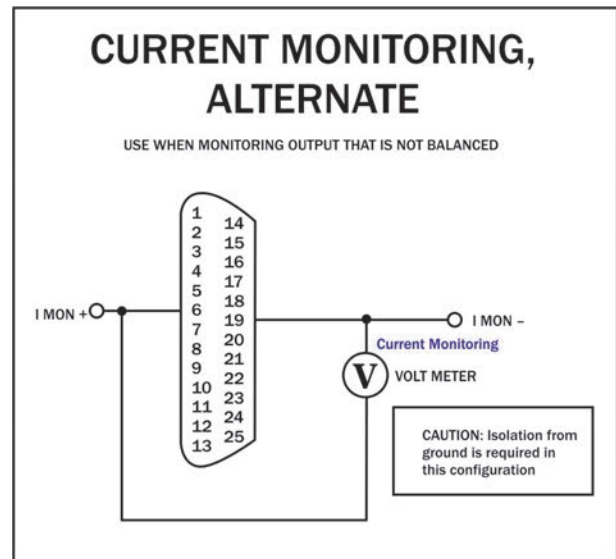

Figure 5.7 – Remote Current Monitoring, Alternate Method

5.2 Controlled Current Operation

The procedures outlined in this section assume competence on the part of the reader in terms of amplifier systems, electronic components, and good electronic safety and working practices.

5.2.1 Controlled-Voltage vs. Controlled-Current Modes of Operation

AE Techron 7224 amplifiers can be field-configured to operate as **Voltage Amplifiers** (Voltage-Controlled Voltage Source) or as **Transconductance Amplifiers** (Voltage-Controlled Current Source). The mode selection is made via a jumper setting located on the amplifier main board. See the “**Advanced Configuration**” section for more information.

When configured as a **Controlled-Voltage** source (voltage amplifier), the amplifier will provide an output voltage that is constant and proportional to the control (input) voltage. If the load's impedance changes, the amplifier will seek to maintain this ratio of input to output voltage by increasing or decreasing the current it produces, as long as it is within the amplifier's ability to create the required current. Use this mode if you want the output voltage waveform to be like the input waveform (see **Figure 5.8**).

CONTROLLED-VOLTAGE MODE

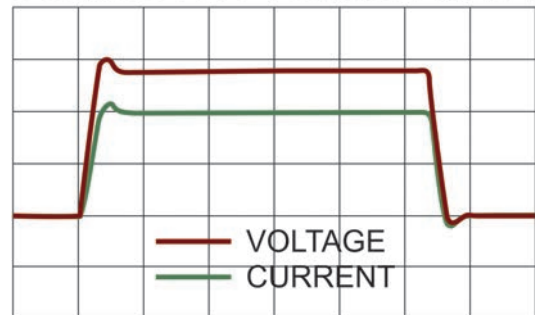

Figure 5.8 – Input to Output Comparison, Controlled-Voltage Operation

Conversely, when configured as a **Controlled-Current** source (transconductance amplifier), the amplifier will provide an output current that is constant and proportional to the control (input) voltage. If the load's impedance changes, the amplifier will seek to maintain this transconductance (ratio of input voltage to output current) by increasing or decreasing the voltage it produces, as long as it is within the amplifier's ability to create the required voltage. Use this mode if you want the output current waveform to be like the input waveform (see **Figure 5.9**).

CONTROLLED-CURRENT MODE

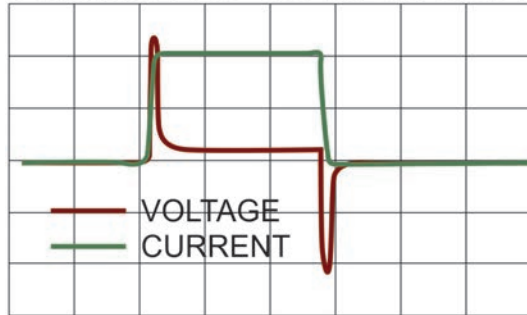

Figure 5.9 – Input to Output Comparison, Controlled-Current Operation

5.2.2 Safety and Operation Considerations for Controlled Current Operation

When an AE Techron amplifier is configured as a Controlled Current source, care needs to be exercised in its operation. **Any voltage controlled current source should never be turned on without a load, (with some impedance, real or effective) connected to its output terminals.** When asked to operate in this way, any current source (including an AE Techron amplifier) will increase its output voltage in an attempt to drive the requested current into the load. In an open-circuit condition, creating current flow will be impossible. The current source will increase its output voltage until it reaches its voltage limit. This is a potentially dangerous condition for both the AE Techron amplifier and for any user who might come in contact with the amplifier output terminals.

When operating in Controlled Current (CC) mode, a compensation circuit is required to ensure accurate output current. Since the load is a critical circuit component in CC mode, the inductive and resistive values of the load will determine the required compensation values. While the factory-default compensation setting will be sufficient for some applications, the compensation setting may also be adjusted in the field. The following section describes methods for determining and setting proper compensation when operating in Controlled-Current mode.

5.2.3 Controlling Compensation for CC Operation

AE Techron 7224 amplifiers can be configured for either Controlled Voltage (CV) or Controlled Current (CC) mode of operation. When operating the amplifier in Controlled Voltage (CV) mode, compensation is not required. However, when operating in Controlled Current (CC) mode, the amplifier load becomes an integral part of the system. In order to ensure system stability and to control available bandwidth, compensation via an RC network is required for CC operation. The following steps will allow you to compensate your amplifier for operation in CC mode safely and effectively.

STEP 1: Check Amplifier Operation in CV mode.

We recommend that you power-up and enable the amplifier in Controlled Voltage mode without attaching a load before configuring your amplifier for Controlled Current operation. This will allow you to verify that the input signal and the amplifier are operating correctly.

Once this initial check is completed, power down the amplifier and access the amplifier main board to place the amplifier in CC mode. (Refer to the “**Advanced Configuration**” section for more information.)

One of two compensation settings can be selected via jumpers on the main board: CC1 which enables the factory-installed RC network (see **Figure 5.10**), or CC2 which allows installation of a custom RC network.

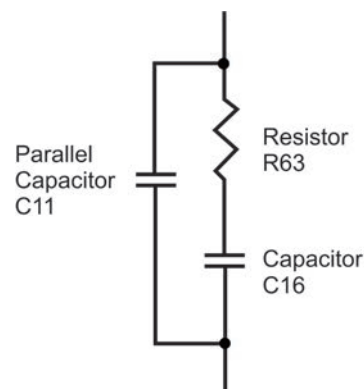

Figure 5.10 – Factory-installed Default RC Network

STEP 2: Determine Required Compensation.

When operating an amplifier in Controlled Current mode, the load becomes an integral part of the system. In order to determine the required compensation for your load, begin by consulting

the following table to determine the approximate compensation capacitance (C) required based on the inductance of your load:

	Load Inductance (L)		
	<200 μ H	<>200 μ H – <1 mH	>1 mH
Compensation Capacitance (CC)	0.001 μ F	0.01 μ F	0.1 μ F

NOTE: Load Resistance (R) is assumed to be <5 ohms.

STEP 3: Determine if Default or Custom Compensation is Required.

If your load inductance is between 200 microHenries and 1 milliHenry, and your load resistance is less than 5 ohms, then you can likely use the default compensation provided by the amplifier's factory-installed RC network. To select the factory-default compensation, please see **STEP 4** below.

If your load inductance falls outside of the mid-range, or if your load resistance is greater than 5 ohms, then you must calculate your required compensation. If, after calculating your required compensation, you determine that the default compensation will be insufficient for your load, then you will need to enable and install a custom RC network. See **STEP 6** below.

STEP 4: Enabling Your Compensation Setting.

AE Techron 7000 Series amplifiers can be enabled with one of two compensation settings: default RC network or custom RC network. The required network can be selected via jumpers on the main board. CC1 enables the default (factory-installed) RC network, while CC2 allows installation of a custom RC network. **Figure 5.10** describes the default RC circuit.

To select CC1, place jumper J5 in the UP position; to select CC2, place jumper J5 in the DOWN position. (For jumper location, see the "**Advanced Configuration**" section.)

IMPORTANT: If CC2 is selected, you must calculate the compensation requirements for your custom RC network and install the network on your amplifier main board before operating the amplifier in CC mode.

STEP 5: (Optional) Verify Suitability of Default Compensation (CC1)

If desired, the following values of the components contained in the default RC network can be used with the formulas provided in **STEP 6** below to verify the suitability of the default compensation for your uses.

Pins Jumped: 1 and 2 (UP)

Compensation Resistor: R63 (68 Kohms)

Compensation Capacitor: C16 (0.047 μ F)

Parallel Capacitor: C11 (47 pF)

STEP 6: Installing an RC Network for Custom Compensation

If the default RC network does not provide suitable compensation for your intended load, you will need to install a custom RC network that is matched to your load. This network will require two components (a resistor (R) and a capacitor (C)) to be installed on the main board. To calculate the approximate values required for each component, use the following formulas.

COMPENSATION FORMULAS:

To find the value for the resistor (Rc) in the RC network:

$$R_c = 20,000 \times 3.14 \times L \times BW$$

where:

Rc is compensation resistance in ohms.

L is load inductance in henries.

BW is bandwidth in hertz.

To find the value for the capacitor (Cc) in the RC network:

$$C_c = L / (R \times R_c)$$

where:

Cc is compensation capacitance in farads.

L is load inductance in henries.

R is resistance of load in ohms.

Rc is compensation resistance in ohms.

STEP 7: Optimizing the Compensation Values.

Once an approximate Rc and Cc have been computed, these values will need to be evaluated. To do this, install components with the required values in the main board at locations R82 and C25 as shown in **Figure 5.11**.

Remember the load you are connecting is a part of the system and the amplifier should not be turned on without the load being connected.

After installing the components, check to ensure that jumper J5 is correctly installed (see **STEP 4**), then power up the amplifier without signal input.

To begin testing, input a square wave with a frequency of 100 Hz to 1 kHz, or a squared pulse at a low level (typically 0.25 to 2.0 volts). A limited-rise-time, repetitive pulse of low duty cycle is preferred.

Observe the output current through a current monitor or current probe. Look for clean transition edges. The presence of ringing or rounding on the transition edges indicates compensation problems. (See **Figure 5.12**.)

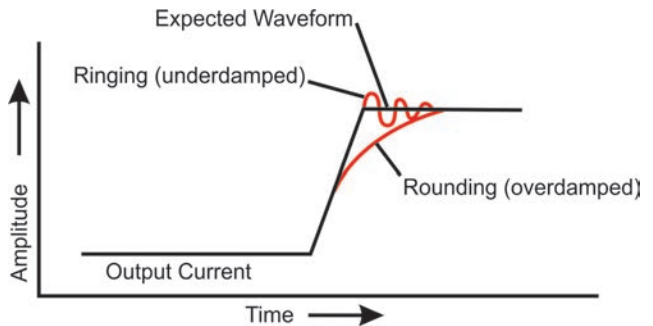

Figure 5.12 – Compensation Effects on Waveform

If a change in compensation is necessary, an adjustment to the resistor component of the Compensation circuit is probably required.

If the output current waveform is ringing, the circuit is underdamped: You have too much gain and should lower the resistance (see **Figure 5.13**).

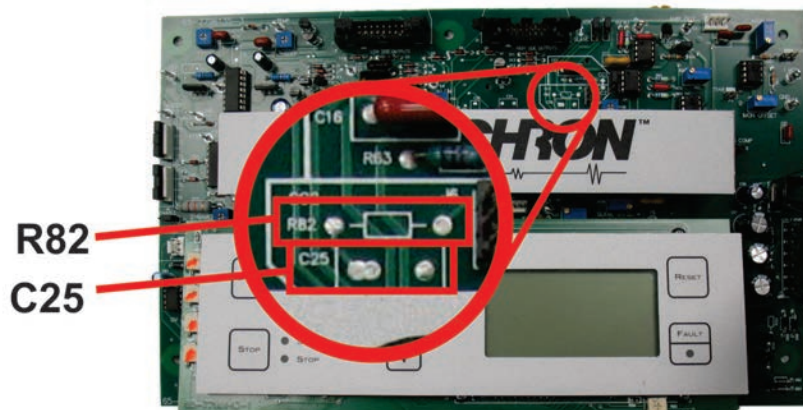
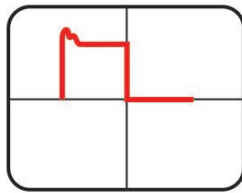

Figure 5.11 – Custom Compensation Location



Decrease R

Figure 5.13 – Square Wave Showing a Decrease in R is Required

If the output current waveform is rounded, the circuit is overdamped: You have too little gain and should increase resistance (see **Figure 5.14**).

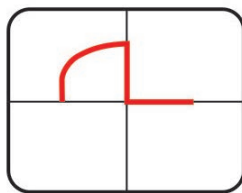

Increase R

Figure 5.14 – Square Wave Showing an Increase in R is Required

If the output current waveform is neither underdamped or overdamped, but the top of the square-wave is not level, then you should instead increase the capacitor value (see **Figure 5.15**).

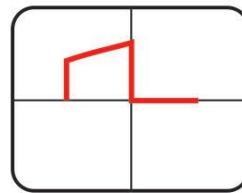

Increase C

Figure 5.15 – Square Wave Showing an Increase in C is Required

When making adjustments:

Resistor: Increase or decrease resistance values in increments of +/- 10%.

Capacitor: Incrementally increase capacitor values by a factor of 2 or 3.

After final adjustments have been made to the circuit, the final waveform for your planned application should be tested to confirm the amplifier's compensation setting.

NOTE:

- If possible, use 1% metal film resistors. AE Techron discourages installation of potentiometers in the resistor location of the compensation circuit because this can decrease stability and may increase inductance.
- The parallel capacitor in the RC network serves to increase stability but can be removed, if it is not required for system stability. If the parallel capacitor is used, it will usually decrease the value of resistance needed.
- In multiple amplifier systems, expect to decrease the value of R63 in series systems by 1/2.

5.3 Multi-amplifier Systems

The 7224 amplifier may be used with other 7224 amplifiers to increase voltage or current. Because the internal circuitry of a 7224 amplifier is not connected to chassis ground, the amplifier is well suited for use in series or parallel with other 7224 amplifiers.

Up to three 7224 amplifiers may be configured in series, and up to four may be configured in parallel. Configurations with more amplifiers may be possible, depending on the application. Please contact AE Techron **Application Support** for information on these more complex multi-amp systems.

For routine, controlled-voltage applications, Series or Parallel amplifier systems can be configured using the following accessories available from AE Techron:

SIM-OPTOC – The SIM-BNC-OPTOC Specialized Input Module allows multiple 7000-Series amplifiers to be configured as a series output system to increase the available output voltage to the load. The SIM-BNC-OPTOC kit also includes a BNC connector safety cover.

The SIM-BNC-OPTOC module is required for all Series configurations and should be used in conjunction with the DB9M CABLE (see below).

DB9M CABLE – The DB9M (OPTOC) CABLE is a high-voltage Interlock cable that provides superior insulation for multi-amp series systems running high-voltage applications.

The DB9M CABLE is required for all Series configurations and should be used in conjunction with the SIM-BNC-OPTOC module (see above)

BAL RES KIT – Three types available: 7224 BAL RES KIT, 7548 BAL RES KIT and 7796 BAL RES KIT. Ballast resistors are required for all Parallel configurations. The ballast resistor kits include one ballast resistor (two in the 7796 kit) with connection terminals and mounting hardware. The 7224 BAL RES KIT also contains the shunt required to defeat the amplifier's external level control.

PARALLEL WIRING KITS – Six types available: 7224 2-AMP, 7548/7796 2-AMP, 7224 3-AMP, 7548/7796 3-AMP, 7224 4-AMP, and 7548/7796 4-AMP. Parallel wiring kits include the DB-25 Interlock cable for system communication, BNC T-connectors and BNC patch cables for wiring parallel inputs through the BNC input connectors, and the output wiring for connecting system amplifiers to the load. The kits also include the wire(s) needed for wiring the parallel inputs through the Removable Barrier Block (WECO) connectors and the .input terminators required during system setup. Parallel wiring kits are recommended for all Parallel configurations.

To download the AE Techron **7000-Series Multi-Amp Configuration Guide** or for additional information, visit the AE Techron website at www.aetechron.com.

5.3.1 Accessory Recommendations by System Type

Series Systems

7224 Two in Series:

- (2) SIM-BNC-OPTOC input cards,
- (1) DB9M OPTOC cable

7224 Three in Series:

- (3) SIM-BNC-OPTOC input cards,
- (2) DB9M OPTOC cables

Parallel Systems

7224 Two in Parallel:

- (2) 7224 BAL RES kits,
- (1) 7224 2-AMP Parallel Wiring kit

7224 Three in Parallel:

- (3) 7224 BAL RES kits,
- (1) 7224 3-AMP Parallel Wiring kit

7224 Four in Parallel:

- (4) 7224 BAL RES kits,
- (1) 7224 4-AMP Parallel Wiring kit

5.3.2 Multi-Amp System Output Capabilities

Two 7224s in Series – High-Voltage Mode

Ohms	PEAK OUTPUT						RMS OUTPUT					
	40 mSec Pulse, 20% Duty Cycle		5 Minutes, 100% Duty Cycle		1 Hour, 100% Duty Cycle		5 Minutes, 100% Duty Cycle		1 Hour, 100% Duty Cycle			
	Volts	Amps	Volts	Amps	Volts	Amps	Volts	Amps	Volts	Amps	Watts	
32	316	9.8	316	9.8	316	9.8	223	6.9	223	6.9	1539	
16	308	19	272	16.3	272	16.3	192	11.5	192	11.5	2208	
8	248	31	216	25.7	122	14.5	153	18.2	86	10.3	886	
4	196	49										

Two 7224s in Series – Mid-Level Mode

Ohms	PEAK OUTPUT						RMS OUTPUT					
	40 mSec Pulse, 20% Duty Cycle		5 Minutes, 100% Duty Cycle		1 Hour, 100% Duty Cycle		5 Minutes, 100% Duty Cycle		1 Hour, 100% Duty Cycle			
	Volts	Amps	Volts	Amps	Volts	Amps	Volts	Amps	Volts	Amps	Watts	
8	144	18	138	16.4	138	16.4	98	11.6	98	11.6	1137	
4	122	30	114	26.2	114	26.2	81	18.5	81	18.5	1499	
2	94	47	86	39.6	42	21	61	28	30	14.8	444	
1	52	52										

Two 7224s in Series – High-Current Mode

Ohms	PEAK OUTPUT						RMS OUTPUT					
	40 mSec Pulse, 20% Duty Cycle		5 Minutes, 100% Duty Cycle		1 Hour, 100% Duty Cycle		5 Minutes, 100% Duty Cycle		1 Hour, 100% Duty Cycle			
	Volts	Amps	Volts	Amps	Volts	Amps	Volts	Amps	Volts	Amps	Watts	
2	*	*	58	29	58	29	41	20.5	41	20.5	841	
1.5	*	*	52	34	52	34	37	24	37	24	888	
1	*	*	46	45	46	45	33	31.8	33	31.8	1049	

Three 7224s in Series – High-Voltage Mode

Ohms	PEAK OUTPUT						RMS OUTPUT					
	40 mSec Pulse, 20% Duty Cycle		5 Minutes, 100% Duty Cycle		1 Hour, 100% Duty Cycle		5 Minutes, 100% Duty Cycle		1 Hour, 100% Duty Cycle			
	Volts	Amps	Volts	Amps	Volts	Amps	Volts	Amps	Volts	Amps	Watts	
48	474	9.8	474	9.8	474	9.8	335	6.9	335	6.9	2312	
24	462	16.3	408	16.3	408	16.3	288	11.5	288	11.5	3312	
12	372	31	324	25.7	183	14.5	229	18.2	129	10.3	1322	
6	294	49										

Three 7224s in Series – Mid-Level Mode

Ohms	PEAK OUTPUT						RMS OUTPUT					
	40 mSec Pulse, 20% Duty Cycle		5 Minutes, 100% Duty Cycle		1 Hour, 100% Duty Cycle		5 Minutes, 100% Duty Cycle		1 Hour, 100% Duty Cycle			
	Volts	Amps	Volts	Amps	Volts	Amps	Volts	Amps	Volts	Amps	Watts	
12	216	18	207	16.4	207	16.4	146	11.6	146	11.6	1693	
6	183	30	171	26.2	171	26.2	121	18.5	121	18.5	2241	
3	141	47	129	39.6	63	21	91	28	44.5	14.8	661	
1.5	78	52										

Three 7224s in Series – High-Current Mode

Ohms	PEAK OUTPUT						RMS OUTPUT				
	40 mSec Pulse, 20% Duty Cycle		5 Minutes, 100% Duty Cycle		1 Hour, 100% Duty Cycle		5 Minutes, 100% Duty Cycle		1 Hour, 100% Duty Cycle		
	Volts	Amps	Volts	Amps	Volts	Amps	Volts	Amps	Volts	Amps	Watts
3	*	*	87	29	87	29	61.5	20.5	61.5	20.5	1261
2.25	*	*	78	34	78	34	55	24	55	24	1322
1.5	*	*	69	45	69	45	49	31.8	49	31.8	1559

Two Paralleled 7224s – High-Voltage Mode

Ohms	PEAK OUTPUT						RMS OUTPUT				
	40 mSec Pulse, 20% Duty Cycle		5 Minutes, 100% Duty Cycle		1 Hour, 100% Duty Cycle		5 Minutes, 100% Duty Cycle		1 Hour, 100% Duty Cycle		
	Volts	Amps	Volts	Amps	Volts	Amps	Volts	Amps	Volts	Amps	Watts
8	158	19.6	158	19.6	158	19.6	112	13.9	112	13.9	1557
4	154	38	136	32.6	136	32.6	96	23	96	23	2213
2	124	62	108	51.4	61	29	76	36.3	43	20.5	882
1	98	98									

Two Paralleled 7224s – Mid-Level Mode

Ohms	PEAK OUTPUT						RMS OUTPUT				
	40 mSec Pulse, 20% Duty Cycle		5 Minutes, 100% Duty Cycle		1 Hour, 100% Duty Cycle		5 Minutes, 100% Duty Cycle		1 Hour, 100% Duty Cycle		
	Volts	Amps	Volts	Amps	Volts	Amps	Volts	Amps	Volts	Amps	Watts
2	144	18	69	32.8	69	32.8	49	23.2	49	23.2	1136
1	122	30	57	54.4	57	54.4	40	38.5	40	38.5	1538
0.5	94	47	43	79.2	21	42	30.4	14.9	14.8	29.7	439
0.25	52	52									

Two Paralleled 7224s – High Current Mode

Ohms	PEAK OUTPUT						RMS OUTPUT				
	40 mSec Pulse, 20% Duty Cycle		5 Minutes, 100% Duty Cycle		1 Hour, 100% Duty Cycle		5 Minutes, 100% Duty Cycle		1 Hour, 100% Duty Cycle		
	Volts	Amps	Volts	Amps	Volts	Amps	Volts	Amps	Volts	Amps	Watts
0.5	*	*	29	58	29	58	20.5	41	20.5	41	841
0.375	*	*	26	68	26	68	18.4	48.1	18.4	48.1	885
0.25	*	*	22.7	90	22.7	90	16	63.6	16	63.6	1018

Three Paralleled 7224s – High-Voltage Mode

Ohms	PEAK OUTPUT						RMS OUTPUT				
	40 mSec Pulse, 20% Duty Cycle		5 Minutes, 100% Duty Cycle		1 Hour, 100% Duty Cycle		5 Minutes, 100% Duty Cycle		1 Hour, 100% Duty Cycle		
	Volts	Amps	Volts	Amps	Volts	Amps	Volts	Amps	Volts	Amps	Watts
5.34	158	29.4	158	29.4	158	29.4	112	20.8	112	20.8	2328
2.67	1574	57	136	48.9	136	48.9	96	34.6	96	34.6	3319
1.34	124	93	108	77.1	61	43.5	76	54.5	43	30.8	1322
0.67	98	147									

Three Paralleled 7224s – Mid-Level Mode

Ohms	PEAK OUTPUT						RMS OUTPUT				
	40 mSec Pulse, 20% Duty Cycle		5 Minutes, 100% Duty Cycle		1 Hour, 100% Duty Cycle		5 Minutes, 100% Duty Cycle		1 Hour, 100% Duty Cycle		
	Volts	Amps	Volts	Amps	Volts	Amps	Volts	Amps	Volts	Amps	Watts
1.34	144	54	69	49.2	69	49.2	49	34.8	49	34.8	1704
0.67	122	90	57	78.6	57	78.6	40	55.6	40	55.6	2223
0.34	94	141	43	118.8	21	63	30.4	84	14.8	44.5	659
0.167	52	156									

Three Paralleled 7224s – High-Current Mode

Ohms	PEAK OUTPUT						RMS OUTPUT				
	40 mSec Pulse, 20% Duty Cycle		5 Minutes, 100% Duty Cycle		1 Hour, 100% Duty Cycle		5 Minutes, 100% Duty Cycle		1 Hour, 100% Duty Cycle		
	Volts	Amps	Volts	Amps	Volts	Amps	Volts	Amps	Volts	Amps	Watts
0.34	*	*	29	87	29	87	20.5	61.5	20.5	61.5	1261
0.25	*	*	26	102	26	102	18.4	72.1	18.4	72.1	1327
0.167	*	*	22.7	135	22.7	135	16	95.5	16	95.5	1527

Four Paralleled 7224s – High-Voltage Mode

Ohms	PEAK OUTPUT						RMS OUTPUT				
	40 mSec Pulse, 20% Duty Cycle		5 Minutes, 100% Duty Cycle		1 Hour, 100% Duty Cycle		5 Minutes, 100% Duty Cycle		1 Hour, 100% Duty Cycle		
	Volts	Amps	Volts	Amps	Volts	Amps	Volts	Amps	Volts	Amps	Watts
4	158	39.2	158	39.2	158	39.2	112	27.7	112	27.7	3104
2	154	76	136	65.2	136	65.2	96	46.1	96	46.1	4425
1	124	124	108	102.8	61	58	76	72.7	43	41	1763
0.5	98	196									

Four Paralleled 7224s – Mid-Level Mode

Ohms	PEAK OUTPUT						RMS OUTPUT				
	40 mSec Pulse, 20% Duty Cycle		5 Minutes, 100% Duty Cycle		1 Hour, 100% Duty Cycle		5 Minutes, 100% Duty Cycle		1 Hour, 100% Duty Cycle		
	Volts	Amps	Volts	Amps	Volts	Amps	Volts	Amps	Volts	Amps	Watts
1	144	72	69	65.6	69	65.6	49	46.4	49	46.4	2273
0.5	122	120	57	104.8	57	104.8	40.3	74.1	40.3	74.1	2986
0.25	94	188	43	158.4	21	84	30.4	112	14.8	59.4	879
0.125	52	208									

Four Paralleled 7224s – High-Current Mode

Ohms	PEAK OUTPUT						RMS OUTPUT				
	40 mSec Pulse, 20% Duty Cycle		5 Minutes, 100% Duty Cycle		1 Hour, 100% Duty Cycle		5 Minutes, 100% Duty Cycle		1 Hour, 100% Duty Cycle		
	Volts	Amps	Volts	Amps	Volts	Amps	Volts	Amps	Volts	Amps	Watts
0.25	*	*	29	116	29	116	20.5	82	20.5	82	1681
0.1875	*	*	26	136	26	136	18.4	96.2	18.4	96.2	1769
0.125	*	*	22.7	180	22.7	180	16	127.3	16	127.3	2036

6 Amplifier Signal Flow

6.1 Input Signals

The input signal is routed from the SIM (Specialized Input Module) on the back panel to the Main board. From there, the signal is amplified through low-noise operational amplifier gain stages, compensation networks, and current limiting/ODEP and then final gain stage to the Output board. At the Output board, the signal is sent through pre-drivers, output stage drivers, then to the Output stage whose topology is a full-complimentary, full-bridge, AB+B mode transistor design. Amplifier control and status is handled by logic circuits tied to the Display/Control board on the front panel. Protection is provided by current limiting circuits and special junction temperature simulation circuits using thermal feedback from the main heat sinks on the Output board.

6.2 AC Mains Power

Power to the amplifier is connected through a 20-amp IEC-type inlet connector with an integral EMI filter network on the back panel. AC mains power is first routed through the front panel switch/breaker, then to the Power Supply board. From there, the AC mains are distributed to the main power transformers, and then from the transformers back through the Power Supply board to the Main board.

The Power Supply board allows for easy configuration of primary and secondary voltages. The Power Supply board also performs the “bi-level” function. This allows the power supply rails to the Output section to increase or decrease depending on demand and keeps the voltage dropped across the outputs to a minimum, thereby decreasing heat dissipation.

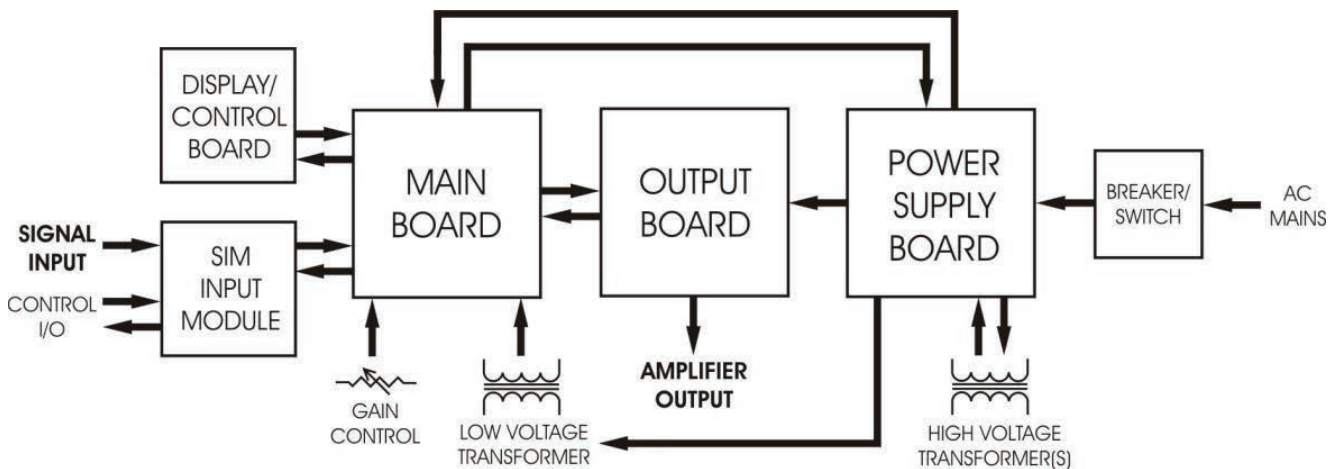
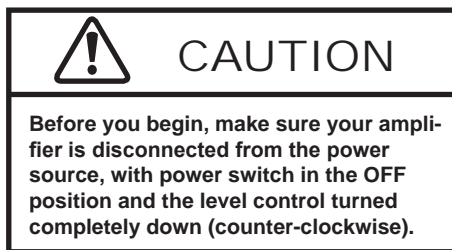

Figure 6.1 – Board-Level Functional Block Diagram

7 Maintenance

Simple maintenance can be performed by the user to help keep the equipment operational. The following routine maintenance is designed to prevent problems before they occur. See Section 8, Troubleshooting, for recommendations for restoring the equipment to operation after an error condition has occurred.

Preventative maintenance is recommended after the first 250 hours of operation, and every three months or 250 hours thereafter. If the equipment environment is dirty or dusty, preventative maintenance should be performed more frequently.



7.1 Clean Amplifier Filter and Grills

7.1.1 Tools Required

The recommended equipment and supplies needed to perform the functions required for this task are described below.

- Vacuum cleaner
- Damp cloth (use water only or a mild soap diluted in water)

To ensure adequate cooling and maximum efficiency of the internal cooling fans, the amplifier's front and rear grills should be cleaned periodically. To clean the amplifier grills and filter, complete the following steps:

1. Turn completely down (counter-clockwise) all level controls and turn the amplifier OFF. Disconnect the amplifier from its power source.
2. Using a vacuum cleaner, vacuum the front ventilation grill, including the filter behind the grill, and the back ventilation exit grill.
3. Using a damp cloth, clean the front and rear ventilation grills. Dry with a clean cloth or allow to air dry. **IMPORTANT: Grills should be completely dry before plugging in or restarting amplifier.**

8 Troubleshooting

8.1 Introduction & Precautions

This section provides a set of procedures for identifying and correcting problems with the 7224 amplifier. Rather than providing an exhaustive and detailed list of troubleshooting specifications, this section aims to provide a set of shortcuts intended to get an inoperative amplifier back in service as quickly as possible.

The procedures outlined in this section are directed toward an experienced electronic technician; it assumes that the technician has knowledge of typical electronic repair and test procedures.

Please be aware that the 7224 will undergo frequent engineering updates. As a result, modules and electronic assemblies may not be interchangeable between units. Particularly, the Main board undergoes periodic engineering modifications that may make interchangeability between units impossible.

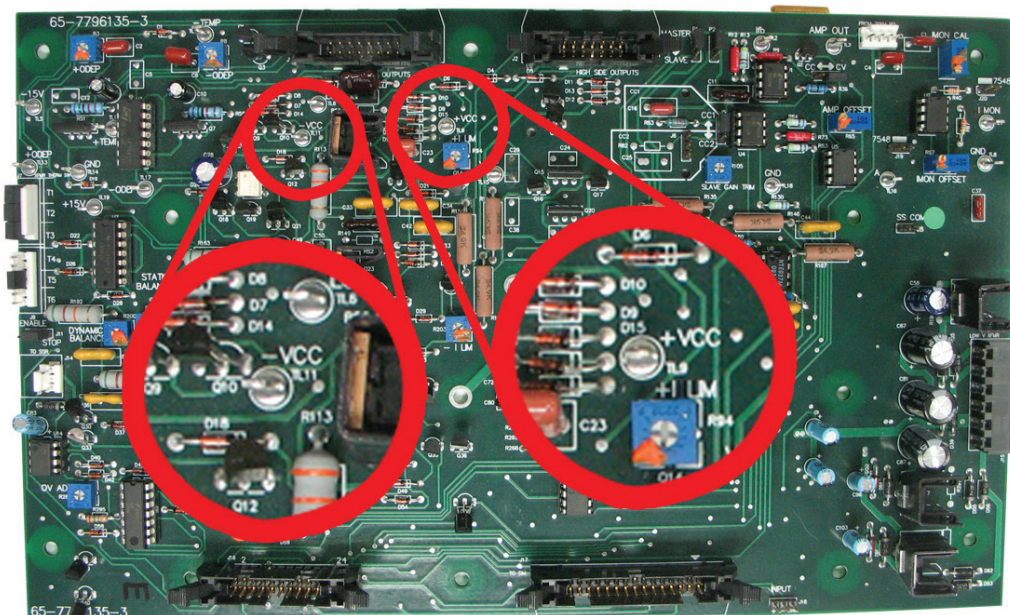
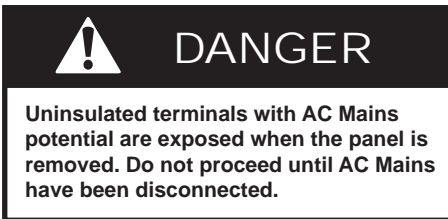

Figure 8.1 – +Vcc and –Vcc Point Locations

8.2 Visual Inspection

Before attempting to troubleshoot the amplifier while it is operating, please take time to complete a visual inspection of the internal components of the amplifier.

1. To perform a Visual Inspection, first turn the Breaker/Switch to the Off (O) position.
2. Disconnect the AC mains plug from the amplifier.
3. Wait three to five minutes for the Power Supply capacitors to discharge. You can verify the capacitor discharge by connecting a voltmeter across +Vcc and –Vcc test points on the main board (see **Figure 8.1**). Verify a reading of less than 50 volts before proceeding.
4. Inspect the amplifier's internal components. Check the following:
 - Inspect modules for charring, breaks, deformation or other signs of physical damage.
 - Look for any foreign objects lodged inside the unit.
 - Inspect the entire lengths of wires and ribbon cables for breaks or other physical damage.

If there is any physical damage to the amplifier, please return it to AE Techron or an AE Techron Service Center for repair.

8.3 No Signal

Missing Output signal may be caused by one of the following:

1. Master/Slave Jumpers are set to the Slave (down) position. The amplifier should only be configured for Slave mode if it is in a multi-amplifier system; otherwise it should be set for Master mode. See the **“Advanced Configuration”** section in this manual for more information.
2. Signal is not connected to any inputs on the SIM card. See the **“Amplifier Setup”** section in this manual for more information.

8.4 No LEDs Illuminated or No Fans

If none of the LEDs on the Display Panel are illuminated and/or the fans are inoperative, check the following:

1. The AC mains are not connected or not on (see the **“Amplifier Setup”** section for more information).
2. Front Panel Breaker/Switch has been tripped. Reset by turning the unit Off (O) and then On.
3. Fuse F1 is open.

To Inspect Fuse F1 follow these steps:

1. Turn Off (O) the amplifier and disconnect the AC mains.
2. Remove Access Panel (see **“Advanced Configuration”**).
3. Locate Fuse F1 (see **Figure 8.2**). Remove fuse and inspect. Replace, if necessary, with same type fuse (T1.6A L 250V).

8.5 OverVoltage LED Lit

The amplifier will protect itself from AC mains voltage that is 10% above the voltage indicated on the back panel. If the AC mains voltage is more than 10% above the operating voltage, reduce the AC mains voltage to the proper level. When the line voltage condition is corrected, the amplifier will automatically reset. If the amplifier does not automatically reset, the amplifier's three internal transformers may need to be rewired. Please see **Section 8.9** for Factory Service information.

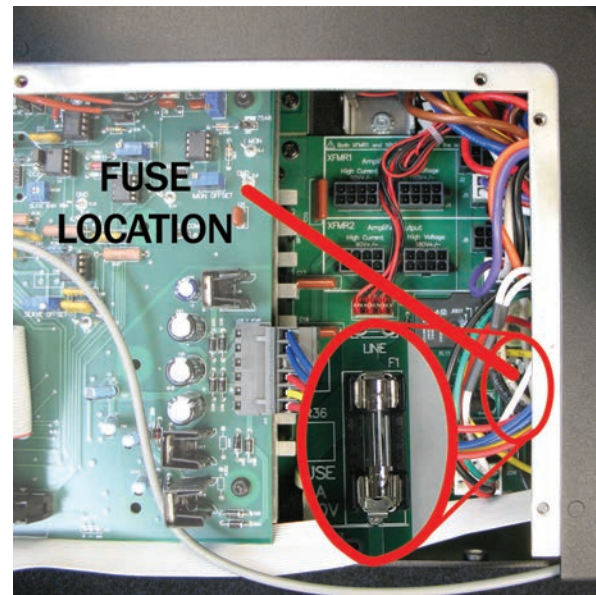

Figure 8.2 – Fuse F1 Location

8.6 Standby LED Remains Illuminated

The Standby indicator may remain illuminated under three conditions:

1. If the output wells or power transformer have overheated. If overheating is the problem, see the following topic (**“Amplifier Overheats”**).
2. If both the Standby and Ready LEDs remain illuminated and the Interlock I/O Cable is being used, the amplifier is being held in Remote Standby mode by another device (see **Figure 8.3**). For more information on 7224 Remote Operation, see the **“Applications”** section in this manual.
3. If the connection to the Interlock – I/O Connector or other input/output connection isn't fully secure. Check all wiring and connections.



Figure 8.3 – Interlock I/O Connector

8.7 Amplifier Overheats (Over Temp Fault Condition)

There are two possible reasons why the 7224 amplifier is overheating:

1. Excessive Power Requirements
2. Inadequate Airflow

8.7.1 Excessive Power Requirements

An amplifier will overheat if the required power exceeds the amplifier's capabilities. High duty cycles and low-impedance loads are especially prone to cause overheating. To see if excess power requirements are causing overheating, check the following:

1. The application's power requirements fall within the specifications of the amplifier. See the "**Specifications**" section.
2. Faulty output connections and load.
3. Undesired DC offset at the Output and Input signal.

If the amplifier chronically overheats with suitable power/load conditions, then the amplifier may not be receiving adequate airflow. To check for adequate airflow, proceed with the following step:

8.7.2 Check for Inadequate Airflow

1. Check air filters. Over time they can become dirty and worn out. It is a good idea to clean the air filters periodically with a mild detergent and water.
2. Visually inspect fans to assure correct operation while amplifier is On (I).

Any inoperative, visibly slow, or reverse-spinning fan should be replaced. Please see the Factory Service information at the end of this section.

An OverTemp condition places the amplifier in Standby mode. If the OverTemp pulse is extremely short, as in the case of defective wiring or switches, the OverTemp pulse may be too brief to observe.

8.7.3 Resetting After OverTemp

When the amplifier has cooled enough to eliminate the OverTemp condition, it should automatically return to Run mode. If the amplifier fails to return to Run mode, make sure fans are running, then remove the input signal from the amplifier. Allow the fans to run for five minutes, and then push the Reset button to reset the amplifier. If the amplifier does not reset, it may require servicing. Please contact AE Techron Technical Support.

8.8 Fault LED is Illuminated

The 7224 contains protection circuitry that disables the amplifier if an output stage is behaving abnormally. This usually indicates an output transistor has shorted.

To clear the Fault condition, follow these steps:

1. Turn off the signal source.
2. Turn off the AC mains.
3. Turn AC mains power back on. If the Fault LED doesn't illuminate again, turn the signal source on.

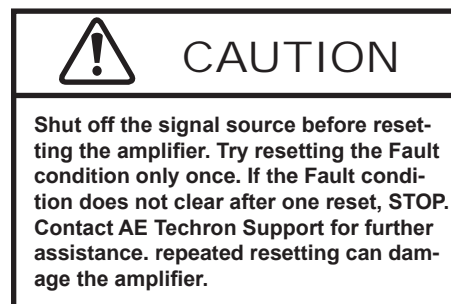

4. If the Fault LED is still illuminated and the Fault condition doesn't clear, return the amplifier for Factory Service. Please see the Factory Service information at the end of this section.

8.9 Factory Service

If the troubleshooting procedures are unsuccessful, the amplifier may need to be returned for Factory Service. All units under warranty will be serviced free of charge (customer is responsible for one-way shipping charges as well as any cus-

tom fees, duties, and/or taxes). Please review the Warranty at the beginning of this manual for more information.

All service units must be given Return Authorization by AE Techron, Inc. before being returned. Return Authorizations can be requested on our website or by contacting our Customer Service Department.

Please take extra care when packaging your amplifier for repair. It should be returned in its original

packaging or a suitable alternative. Replacement packaging materials can be purchased for a nominal fee.

Please send all service units to the following address and be sure to include your Return Authorization Number on the box.

AE Techron, Inc.
Attn: Service Department / RMA#
2507 Warren Street
Elkhart, IN 46516

9 Specifications

Performance

Testing was done at 100 Hz. Continuous DC power levels are lower. See DC Specifications chart.

7224P accuracy was measured when driven into a 10-ohm load with between 0.1VDC and 6VDC or between 0.2VAC and 5VAC presented at its inputs.

Small Signal Frequency Response:

DC - 300 kHz, +0.0 to -1.0 dB

8-Ohm Power Response:

± 140 Vpk DC to 60 kHz

± 50 Vpk DC to 180 kHz

± 30 Vpk DC to 300 kHz

Slew Rate:

75 V/μSec

Residual Noise:

10 Hz to 300 kHz: 950 μV (0.95 mV)

10 Hz to 80 kHz: 300 μV (0.3 mV)

Signal-to-Noise Ratio:

10 Hz - 30 kHz: -113 dB

10 Hz - 80 kHz: -106.6 dB

10 Hz - 300 kHz: -99.9 dB

Unit to Unit Phase Error:

± 0.1 degrees at 60 Hz

THD:

DC - 30 kHz, less than 0.1%

Output Offset:

7724: Less than ±5 mV

7224P: Less than ±400 μV

DC Drift:

7224: <±1.5 mV

7224P: <±200 μV

(after 20 minutes of operation)

Output Impedance:

5.3 mOhm in Series with 0.95 μH

Phase Response:

± 5 degrees (10 Hz - 10 kHz) plus 560 nsec propagation delay

Input Characteristics

Balanced with ground:

Three terminal barrier block connector, 20k ohm differential

Unbalanced:

BNC connector, 10k ohm single ended. Fixed or variable gain

Gain:

Voltage Mode: 20 volts/volt

Current Mode: 5 amperes/volt

Gain Linearity (over input signal, from 0.2V to 5V):

7224: 0.15%

7224P: 0.02% (DC); 0.05% (AC)

Max Input Voltage:

± 10 V balanced or unbalanced

Common Mode Rejection:

-58 dB with 5 V input

Display, Control, Status, I/O

Front Panel LED Displays indicate:

Ready, Standby, Fault, Over Temp, Over Voltage, Overload

Soft Touch Switches for:

Run, Stop, Reset

Gain Control, when enabled:

Voltage gain adjustable from 20 to 0

On/Off Breaker

Back Panel Power Connection:

25 Amp IEC (with retention latch)

Signal Output:

Three-position terminal strip (OUTPUT/COM/CHASSIS GROUND); resistor between COM and CHASSIS GROUND terminals is a 2.7-ohm, 2W, 5%, metal-oxide resistor

Signal Input:

User Selectable BNC or Barrier Strip Balanced

Communication Capabilities

Current Monitor:

± 1 V / 5 A ± 1%

Reporting:

System Fault, Over Temp, Over Voltage, Over Load

Control:

Force to Standby, Reset after a fault

Multiple Unit Configuration

Series Operation:

Total Voltage (1, 2, or 3-7224's): 150 V_{pk}, 300 V_{pk}, or 450 V_{pk}; Increased slew rate up to 150 V/μSec

Parallel Operation:

Total Current (1, 2, 3, or 4-7224's): 50 A_{pk}, 100 A_{pk}, 150 A_{pk} or 200 A_{pk}

Physical Characteristics

Chassis:

The Amplifier is designed for stand-alone or rack-mounted operation. The Chassis is black aluminum with a powder coat finish. The unit occupies two EIA 19-inch-wide units.

Weight:

41 lbs (18.6 kg), Shipping 51 lbs (23.2 kg)

AC Power:

Single phase, 120 VAC, 60 Hz, 20 Amp service; (220-240 VAC, 50-60 Hz, 10 Amp service model available)

Operating Temperature:

10°C to 50°C (50°F to 122°F), maximum output Power de-rated above 30°C (86°F.)

Humidity:

70% or less, non-condensing

Cooling:

Forced air cooling from front to back through removable filters.

Airflow:

180CFM

Dimensions:

19" x 22.75" x 3.5" (48.3 cm x 57.8 cm x 8.9 cm)

Protection

Over/Under Voltage:

± 10% from specified supply voltage amplifier is forced to Standby

Over Current:

Breaker protection on both main power and low voltage supplies

Over Temperature:

Separate Output transistor, heat sink, and transformer temperature monitoring and protection

DC Specifications – High-Current Mode

Volts DC	5 Minutes		1 Hour	
	Amps DC		Amps DC	
24.0	26	20	20	16
13.5	20	16	16	16
3.0*	25	25	25	25

* A 120VAC-only special configuration.

AC Specifications – High-Voltage Mode

Ohms	PEAK OUTPUT						RMS OUTPUT					
	40 mSec Pulse, 20% Duty Cycle		5 Minutes, 100% Duty Cycle		1 Hour, 100% Duty Cycle		5 Minutes, 100% Duty Cycle		1 Hour, 100% Duty Cycle		Watts	
	Volts	Amps	Volts	Amps	Volts	Amps	Volts	Amps	Volts	Amps		
16	158	9.8	158	9.8	158	9.8	112	6.9	112	6.9	773	
8	154	19	136	16	136	16	96	11.5	96	11.5	1104	
4	124	31	108	25.7	61	14.5	76	18.2	43	10.3	443	
2	98	49										

AC Specifications – Mid-Level Mode

Ohms	PEAK OUTPUT						RMS OUTPUT					
	40 mSec Pulse, 20% Duty Cycle		5 Minutes, 100% Duty Cycle		1 Hour, 100% Duty Cycle		5 Minutes, 100% Duty Cycle		1 Hour, 100% Duty Cycle		Watts	
	Volts	Amps	Volts	Amps	Volts	Amps	Volts	Amps	Volts	Amps		
4	72	18	69	16.4	69	16.4	49	12	49	11.6	568	
2	61	30	57	26.2	57	26.2	40	19	40	18.5	740	
1	47	47	43	39.6	21	21	30	28	15	14.8	222	
0.5	26	52										

AC Specifications – High-Current Mode

Ohms	PEAK OUTPUT						RMS OUTPUT					
	40 mSec Pulse, 20% Duty Cycle		5 Minutes, 100% Duty Cycle		1 Hour, 100% Duty Cycle		5 Minutes, 100% Duty Cycle		1 Hour, 100% Duty Cycle		Watts	
	Volts	Amps	Volts	Amps	Volts	Amps	Volts	Amps	Volts	Amps		
1			29	29	29	29	21	21	20.5	20.5	420	
0.75			26	34	26	34	18	24	18	24	432	
0.5			22.7	45	22.7	45	16	32	16	32	512	

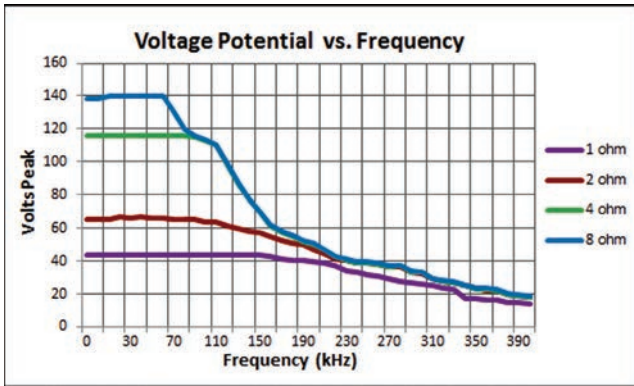

Figure 9.1 – Voltage Potential vs. Frequency

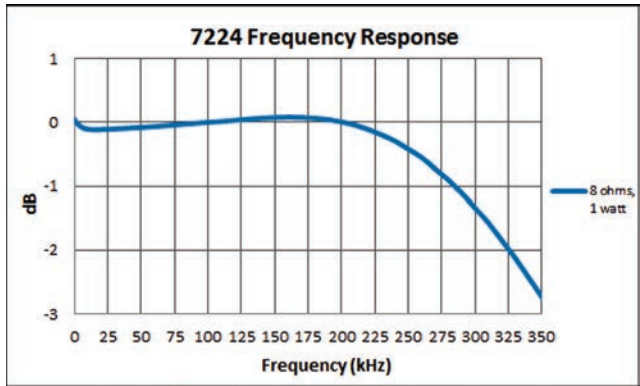

Figure 9.2 – Frequency Response

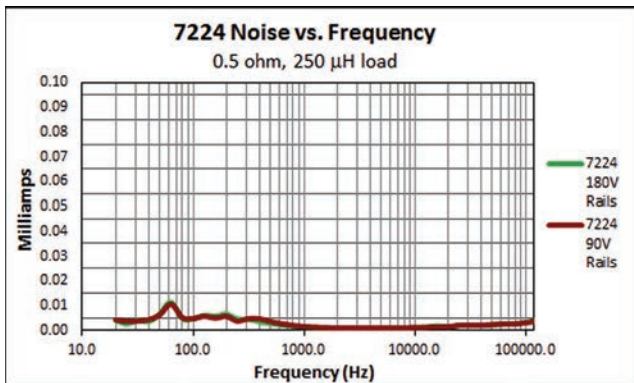

Figure 9.3 – Noise vs. Frequency

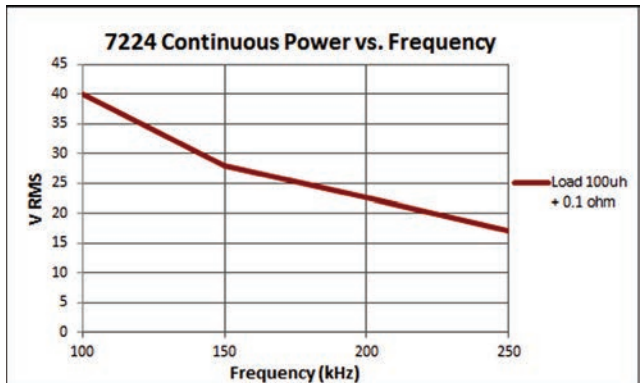

Figure 9.4 – Continuous Power vs. Frequency

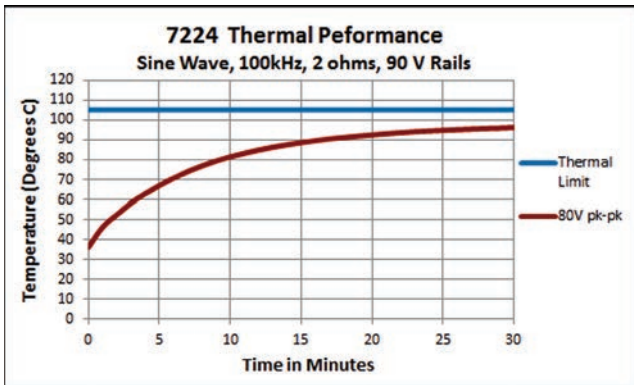

Figure 9.5 – Thermal Performance

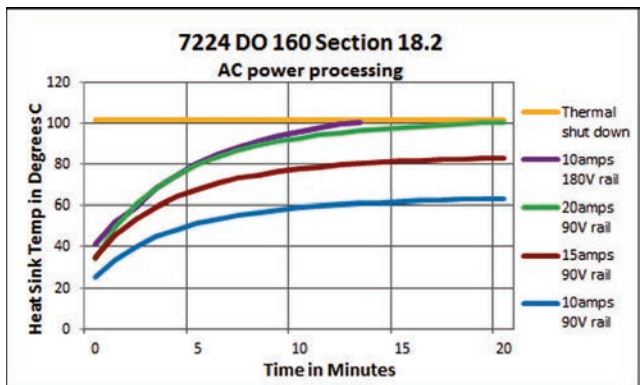

Figure 9.6 – DO 160 Section 18.2 AC Power Processing

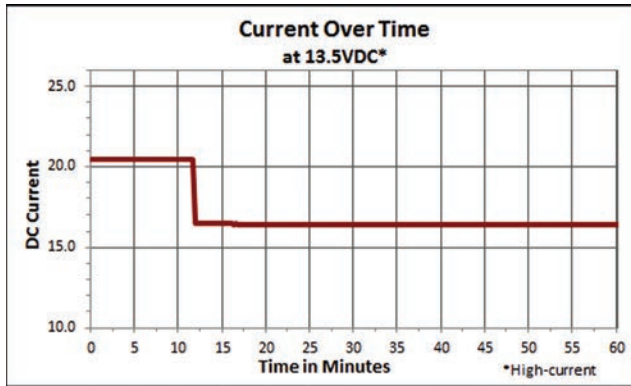

Figure 9.7 – DC Current Over Time at 13.5 VDC

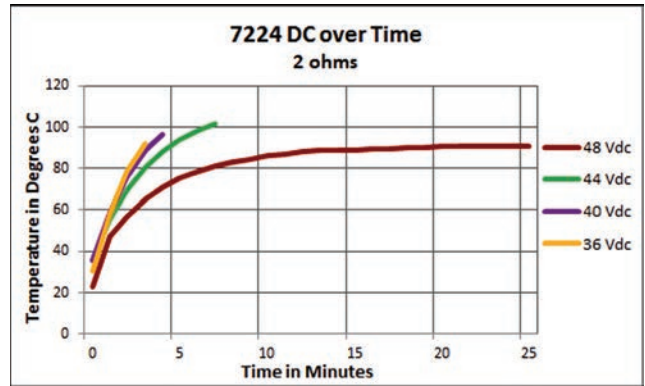

Figure 9.8 – DC Current Over Time 2-ohm Load

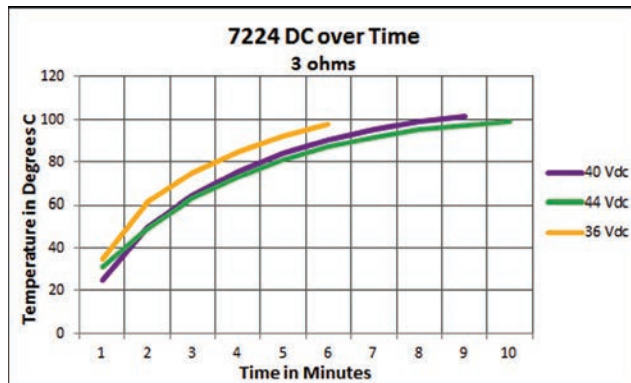

Figure 9.9 – DC Current Over Time 3-ohm Load

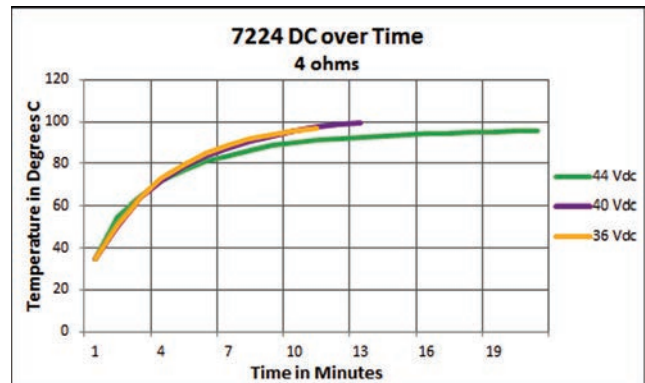

Figure 9.10 – DC Current Over Time 4-ohm Load

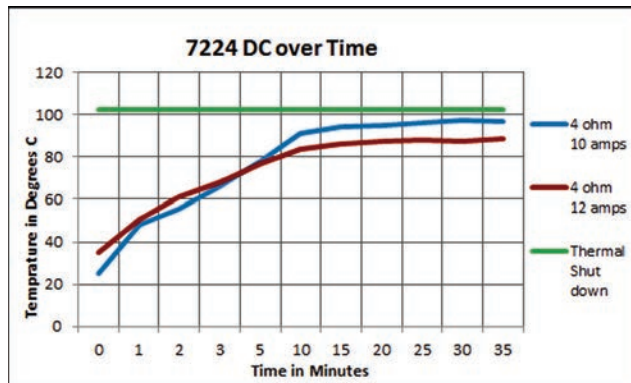

Figure 9.11 – DC Current Over Time Comparison with 4-ohm Load

Appendix A: SIM - Interlock I/O Connector Pinouts and Functions

Pin #	Function	Description	Signal Type	Level when Asserted	Level when Deasserted	Notes	Applications
1	Amplifier Output	Used for driving slave amplifiers; monitoring amplifier output voltage	AC or DC	Can be greater than $\pm 200V$ peak	0V	Used for monitoring amplifier output voltage; driving slave amplifiers in multi-amp systems. Wired to amplifier output. Do not connect to any impedance of less than 10K ohm.	Voltage Monitoring: Connect a voltage meter to monitor the output voltage being produced by the amplifier. Connect across PIN 1 (Amp Out) and PIN 10 (Sampled Common).
2	Sampled Common	Load connected here for Current sense	AC or DC	Up to $\pm 2V$ peak relative to Common	0V	Used for driving slave amplifiers in multi-amp systems, controlled voltage or controlled current mode.	Driving Slave Amplifiers: Amplifier External Reference, 2V peak maximum from PIN 14 (Common).
3	+1 IN	Differential Slave input	AC or DC	Can be greater than $\pm 200V$ peak	0V	Only used in multiple amplifier configurations - Series mode.	Can accept output of PIN 1 (Amplifier Output) OR PIN 2 (Sampled Common) from Master device when in Slave mode.
4	Interlock	Amplifier Interlock input	DC	0V to 8V	10V to 15V	When "low", forces to Standby; when allowed to float, allows Run (if amplifier is "Ready"). IMPORTANT: amplifiers must be configured for Run mode at startup (factory default) or the Run button must be pressed at the amplifier front panel at startup.	Remote to Standby: Short PIN 4 of amplifier to Digital Ground (PIN 17) using dry contact switch or optocoupler. When closed, places amplifier in Standby. Multi-amplifier Systems, Simultaneous Enable or Disable of amplifiers: Daisy-chain Interlock (PIN4) across amps (if sharing the same Sampled Common power connections). Optocoupler must be used for multi-amps in series.
5	Amp Ready	Ready output of amplifier	DC	0V	-14V	Normally reserved for OPTOC use; not recommended for normal customer use. Line has series resistor and unloaded will go from 0V (not ready) to -15V (ready), with an OPTOC BNC card the signal will go from 0V (not ready) to -1.2Vdc (ready)	Not recommended for normal customer use.
6	I MON +	Differential Current Monitor +	AC or DC	7212/7224: 5A/V 7548/7796: 20A/V		Output current produced per voltage detect.	Current Monitoring: Connect a voltage meter to monitor the output current being produced by the amplifier. For unbalanced, for each 1V detected, current output is 5A (7212/7224) or 20A (7548/7796).
7	None	No connection					Not currently used.
8	None	No connection					Not currently used.
9	Blanking input	Blanking control	DC	0 - 1Vdc allows normal operation	3.5 - 5Vdc output is muted	Used in amplifiers with blanking feature included for blanking control.	Blanking Control: Use an external isolated 5V power supply to mute the output of the amplifier.
10	Sampled Common	Amp Analog Ground; Blanking Ground				Amplifier ground.	Can be used as Blanking return or as a reference of the amplifier for status reporting applications. See Over-Temp (PIN 11), Run (PIN 12), Overload (PIN 23), and OverVoltage (PIN 24).

Pin #	Function	Description	Signal Type	Level when Asserted	Level when Deasserted	Notes	Applications
11	OverTemp Out	Over-temperature output	DC	-24V	0V	When amp is normal, this pin is pulled to -24V through a 47.5K-ohm resistor; when amp is in OverTemp state, this pin is grounded. Do not exceed 7 milliamps.	Remote Signal of Over-Temperature Condition: LED, when lit, signals Over Temperature condition. Use a 6 mA series resistor of 4.7K-ohm for LED or OPTO, tie to -24V source (PIN 13).
12	Run	Amplifier Run output	DC	-24V	0V	When amp is in Standby mode, this pin is pulled to -24V; when amp is in Run mode, this pin is grounded, energizing Mains Relays and allowing drive for an external LED. DO NOT exceed 7mA; DO NOT ground this pin as this will enable Main Power Relays.	Remote Signal of Run Condition: LED, when lit, signals Run state. Use a 6mA series resistor of 4.7K-ohm for LED or OPTO, tie to -24V source (PIN 13).
13	-24V	-24V Power Output	DC			-24V dc, 30 mA max	Internally tied for use in status reporting applications. See OverTemp (PIN 11), Run (PIN 12), Overload (PIN 23), and OverVoltage (PIN 24).
14	Common	Ground before Sense Resistors				Current monitor reference. Voltage between Common and Sampled Common is voltage on the Current Sense resistor.	Possibly series amplifiers will not need current reporting on the High side amp, since its current will be same as Master.
15	-1 IN	Differential Slave Input	AC or DC	Up to 200V peak	0V	Only used in multiple amplifier configurations, Series mode.	Can accept output of PIN 1 (Amplifier Output) OR PIN 2 (Sampled Common) from Master device when in Slave mode.
16	+24V	+24V Power Output	DC			+24V dc, 30 mA max.	Used in status reporting applications. See OverTemp (PIN 11), Run (PIN 12), Overload (PIN 23), and OverVoltage (PIN 24).
17	Digital Ground	Digital circuitry ground - Interlock Common	DC	0V	0V		Used with PIN 25 (Reset) for Remote Reset from Standby or Stop after Error. Used with PIN 4 (Interlock) for simultaneous remote to Standby of all amps in a multi-amplifier system.
18	OEM App	Input Monitor (OEM only)				Used to monitor the input signal from an OEM DAC card; this is the actual input signal.	OEM modification only; normally no connection.
19	I MON - (alt.: OEM App)	Differential Current Monitor - ; (- Input Monitor, OEM only)	AC or DC	7212/7224: 5A/V 7548/7796: 20A/V		Inverted I MON+ (PIN 6). Output current produced per voltage detect.	Current Monitoring: Connect a voltage meter to monitor the output current being produced by the amplifier. For each 1V detected, current output is 5A (7212/7224) or 20A (7548/7796).
20	I SUM1-	Multiple Amplifier Summing, Amplifier 1	DC			Planned for use in multiple amplifier configurations - paralleled and running Controlled Current Mode	Currently not used.

Pin #	Function	Description	Signal Type	Level when Asserted	Level when Deasserted	Notes	Applications
21	I SUM2-	Multiple Amplifier Summing, Amplifier 2	DC			Planned for use in multiple amplifier configurations - paralleled and running Controlled Current Mode	Currently not used.
22	I SUM3-	Multiple Amplifier Summing, Amplifier 3	DC			Planned for use in multiple amplifier configurations - paralleled and running Controlled Current Mode	Currently not used.
23	OverLoad Out	Overload output (amplifier output is clipping).	DC	-24V	0V	When amp is normal, this pin is pulled to -24V through a 47.5K-ohm resistor; when amp is in Overload state, this pin is grounded. Do not exceed 6 milliamps.	Remote Signal of Overload Condition: LED, when lit, signals Overload condition. Use a 6mA series resistor of 4.7K-ohm for LED or OPTO, tie to -24V source (PIN 13).
24	OverVoltage Out	Overvoltage output (High AC line voltage).	DC	-24V	0V	When amp is normal, this pin is pulled to -24V through a 47.5K-ohm resistor; when amp is in Overvoltage state, this pin is grounded. Do not exceed 6 milliamps.	Remote Signal of Overvoltage Condition: LED, when lit, signals Overvoltage condition. Use a 6mA series resistor of 4.7K-ohm for LED or OPTO, tie to -24V source (PIN 13).
25	Reset	Reset	DC	-15V	0V	Tie to PIN 13 (-24V dc) and create a -15V dc source; <2mA required for reset. Connect the -15V dc source to PIN 25 (Reset) through a 1K buffer resistor to reset.	Reset from Standby: Use a dry contact switch and voltage regulator to return amp to Ready/Run condition after Overload conditions. Assert -15V for at least 100 ms to clear error condition.
Gray shaded areas indicate pin not used / feature not implemented.						Blue shaded areas indicate used only in multi-amplifier systems.	