

Keysight Model E4356A

Telecommunications

DC Power Supply

Operating and
Programming Guide

NOTICE: This document contains references to Agilent Technologies. Agilent's former Test and Measurement business has become Keysight Technologies. For more information, go to www.keysight.com.



CERTIFICATION

Keysight Technologies Company certifies that this product met its published specifications at time of shipment from the factory. Keysight Technologies further certifies that its calibration measurements are traceable to the United States National Bureau of Standards, to the extent allowed by the Bureau's calibration facility, and to the calibration facilities of other International Standards Organization members.

WARRANTY

This Keysight Technologies hardware product is warranted against defects in material and workmanship for a period of three years from date of delivery. Keysight Technologies software and firmware products, which are designated by Keysight Technologies for use with a hardware product and when properly installed on that hardware product, are warranted not to fail to execute their programming instructions due to defects in material and workmanship for a period of 90 days from date of delivery. During the warranty period Keysight Technologies Company will, at its option, either repair or replace products which prove to be defective. Keysight Technologies does not warrant that the operation of the software, firmware, or hardware shall be uninterrupted or error free.

For warranty service, with the exception of warranty options, this product must be returned to a service facility designated by Keysight Technologies. Customer shall prepay shipping charges by (and shall pay all duty and taxes) for products returned to Keysight technologies for warranty service. Except for products returned to Customer from another country, Keysight Technologies shall pay for return of products to Customer.

Warranty services outside the country of initial purchase are included in Keysight Technologies' product price, only if Customer pays Keysight Technologies international prices (defined as destination local currency price, or U.S. or Geneva Export price).

If Keysight Technologies is unable, within a reasonable time to repair or replace any product to condition as warranted, the Customer shall be entitled to a refund of the purchase price upon return of the product to Keysight Technologies.

LIMITATION OF WARRANTY

The foregoing warranty shall not apply to defects resulting from improper or inadequate maintenance by the Customer, Customer-supplied software or interfacing, unauthorized modification or misuse, operation outside of the environmental specifications for the product, or improper site preparation and maintenance. NO OTHER WARRANTY IS EXPRESSED OR IMPLIED. KEYSIGHT TECHNOLOGIES SPECIFICALLY DISCLAIMS THE IMPLIED WARRANTIES OF MERCHANTABILITY AND FITNESS FOR A PARTICULAR PURPOSE.

EXCLUSIVE REMEDIES

THE REMEDIES PROVIDED HEREIN ARE THE CUSTOMER'S SOLE AND EXCLUSIVE REMEDIES. KEYSIGHT TECHNOLOGIES SHALL NOT BE LIABLE FOR ANY DIRECT, INDIRECT, SPECIAL, INCIDENTAL, OR CONSEQUENTIAL DAMAGES, WHETHER BASED ON CONTRACT, TORT, OR ANY OTHER LEGAL THEORY.

ASSISTANCE

The above statements apply only to the standard product warranty. Warranty options, extended support contracts, product maintenance agreements and customer assistance agreements are also available. Contact your nearest Keysight Technologies Sales and Service office for further information on Keysight Technologies' full line of Support Programs.

Safety Summary

The following general safety precautions must be observed during all phases of operation, service, and repair of this instrument. Failure to comply with these precautions or with specific warnings elsewhere in this manual violates safety standards of design, manufacture, and intended use of the instrument. Keysight Technologies Company assumes no liability for the customer's failure to comply with these requirements.

GENERAL.

This product is a Safety Class 1 instrument (provided with a protective earth terminal).

Any LEDs used in this product are Class 1 LEDs as per IEC 825-1.

This ISM device complies with Canadian ICES-001. Cet appareil ISM est conforme à la norme NMB-001 du Canada.

ENVIRONMENTAL CONDITIONS

With the exceptions noted, all instruments are intended for indoor use in an installation category II, pollution degree 2 environment.

They are designed to operate at a maximum relative humidity of 95% and at altitudes of up to 2000 meters. Refer to the specifications tables for the ac mains voltage requirements and ambient operating temperature range.

BEFORE APPLYING POWER.

Verify that the product is set to match the available line voltage and the correct fuse is installed.

GROUND THE INSTRUMENT.

To minimize shock hazard, the instrument chassis and cabinet must be connected to an electrical ground. The instrument must be connected to the ac power supply mains through a three-conductor power cable, with the third wire firmly connected to an electrical ground (safety ground) at the power outlet. For instruments designed to be hard-wired to the ac power lines (supply mains), connect the protective earth terminal to a protective conductor before any other connection is made. Any interruption of the protective (grounding) conductor or disconnection of the protective earth terminal will cause a potential shock hazard that could result in personal injury. If the instrument is to be energized via an external autotransformer for voltage reduction, be certain that the autotransformer common terminal is connected to the neutral (earthed pole) of the ac power lines (supply mains).

FUSES.

Only fuses with the required rated current, voltage, and specified type (normal blow, time delay, etc.) should be used. Do not use repaired fuses or short circuited fuseholders. To do so could cause a shock or fire hazard.

DO NOT OPERATE IN AN EXPLOSIVE ATMOSPHERE.

Do not operate the instrument in the presence of flammable gases or fumes.

KEEP AWAY FROM LIVE CIRCUITS.

Operating personnel must not remove instrument covers. Component replacement and internal adjustments must be made by qualified service personnel. Do not replace components with power cable connected. Under certain conditions, dangerous voltages may exist even with the power cable removed. To avoid injuries, always disconnect power, discharge circuits and remove external voltage sources before touching components.

DO NOT SERVICE OR ADJUST ALONE.

Do not attempt internal service or adjustment unless another person, capable of rendering first aid and resuscitation, is present.

DO NOT EXCEED INPUT RATINGS.





















This instrument may be equipped with a line filter to reduce electromagnetic interference and must be connected to a properly grounded receptacle to minimize electric shock hazard. Operation at line voltages or frequencies in excess of those stated on the data plate may cause leakage currents in excess of 5.0 mA peak.

DO NOT SUBSTITUTE PARTS OR MODIFY INSTRUMENT.

Because of the danger of introducing additional hazards, do not install substitute parts or perform any unauthorized modification to the instrument. Return the instrument to a Keysight Technologies Sales and Service Office for service and repair to ensure that safety features are maintained.

Instruments which appear damaged or defective should be made inoperative and secured against unintended operation until they can be repaired by qualified service personnel.

Safety Symbol - Definitions

Symbol	Description	Symbol	Description
	Direct current		Terminal for Line conductor on permanently installed equipment
	Alternating current		Caution, risk of electric shock
	Both direct and alternating current		Caution, hot surface
	Three-phase alternating current		Caution (refer to accompanying documents)
	Earth (ground) terminal		In position of a bi-stable push control
	Protective earth (ground) terminal		Out position of a bi-stable push control
	Frame or chassis terminal		On (unit)
	Terminal for Neutral conductor on permanently installed equipment		Off (unit)
	Terminal is at earth potential (Used for measurement and control circuits designed to be operated with one terminal at earth potential.)		Standby (unit) Units with this symbol are not completely disconnected from ac mains when this switch is off. To completely disconnect the unit from ac mains, either disconnect the power cord or have a qualified electrician install an external switch.
	The WARNING sign denotes a hazard. It calls attention to a procedure, practice, or the like, which, if not correctly performed or adhered to, could result in personal injury. Do not proceed beyond a WARNING sign until the indicated conditions are fully understood and met.		The CAUTION sign denotes a hazard. It calls attention to an operating procedure, or the like, which, if not correctly performed or adhered to, could result in damage to or destruction of part or all of the product. Do not proceed beyond a CAUTION sign until the indicated conditions are fully understood and met.

Acoustic Noise Information

Herstellerbescheinigung

Diese Information steht im Zusammenhang mit den Anforderungen der Maschinenläminformationsverordnung vom 18 Januar 1991. * Schalldruckpegel $L_p < 70$ dB(A) * Am Arbeitsplatz * Normaler Betrieb * Nach EN 27779 (Typprüfung).

Manufacturer's Declaration

This statement is provided to comply with the requirements of the German Sound Emission Directive, from 18 January 1991. * Sound Pressure $L_p < 70$ dB(A) * At Operator Position * Normal Operation * According to EN 27779 (Type Test).

Printing History

The edition and current revision of this manual are indicated below. Reprints of this manual containing minor corrections and updates may have the same printing date. Revised editions are identified by a new printing date. A revised edition incorporates all new or corrected material since the previous printing date. Changes to the manual occurring between revisions are covered by change sheets shipped with the manual. In some cases, the changes apply to specific instruments. Instructions provided on the change sheet will indicate if a particular change applies only to certain instruments.

© Copyright 1999, 2015 Keysight Technologies Company

Edition 1 - August, 1999
Updated: March, 2000; Sept. 2004
Edition 2 - January 2015

This document contains proprietary information protected by copyright. All rights are reserved. No part of this document may be photocopied, reproduced, or translated into another language without the prior consent of Keysight Technologies Company. The information contained in this document is subject to change without notice.

Declaration Page

To obtain the latest Declaration of Conformity, go to <http://www.keysight.com/go/conformity> and click on "Declarations of Conformity."

Table of Contents

Safety Summary	3
Safety Symbol - Definitions	4
Acoustic Noise Information	4
Printing History	4
Declaration Page	5
Table of Contents	6
1 - GENERAL INFORMATION	13
Introduction	13
Safety Considerations	13
Options	14
Accessories	14
Operator Replaceable Parts List	14
Description	15
Front Panel Programming	15
Remote Programming	15
Analog Programming	15
Output Characteristic	16
Output Ranges	16
Downprogramming	16
2 - INSTALLATION	17
Inspection	17
Damage	17
Packaging Material	17
Items Supplied	17
Location and Temperature	18
Bench Operation	18
Rack Mounting	18
Temperature Performance	18
Input Power Source	18
Installing the Power Cord	18
VXI <i>plug&play</i> Power Products Instrument Drivers	20
Downloading and Installing the Driver	20
Accessing Online Help	20
3 - TURN-ON CHECKOUT	21
Introduction	21
Preliminary Checkout	21
Power-On Checkout	21
Using the Keypad	22
Shifted Keys	22
Backspace Key	22
Output Checkout	22
Checking the Voltage Function	22
Checking the Current Function	23
Checking The Save And Recall Functions	24
Determining The GPIB Address	24
In Case Of Trouble	24
Line Fuse	24
Error Messages	25

Selftest Errors	25
Power-On Error Messages	25
Checksum Errors.	26
Runtime Error Messages	26
4 - USER CONNECTIONS	27
Rear Panel Connections	27
Load Wire Selection	27
Analog Connector	27
Connecting the Power supply to the Load	28
Output Isolation	28
Capacitive Loads	28
Inductive Loads	29
Battery Charging	29
Local Voltage Sensing	30
Remote Voltage Sensing	30
Setting Up Remote Sense Operation	30
Connecting the Sense Leads	30
CV Regulation	30
Output Rating	30
Output Noise	30
OVP Considerations	31
Stability	31
Operating Configurations	31
Connecting One Power supply to a Single Load	31
Connecting One Power supply To Multiple Loads	32
Connecting Units in Auto-Parallel	32
Connecting Units in Series	33
External Voltage Control	34
Controller Connections	35
Stand-Alone Connections	35
Linked Connections	35
5 - FRONT PANEL OPERATION	37
Introduction	37
Getting Acquainted	37
Programming The Output	40
Establishing Initial Conditions	40
Programming Voltage	40
Programming Overvoltage Protection	40
Programming Current	41
Programming Overcurrent Protection	42
CV Mode vs. CC Mode	42
Unregulated Operation	42
Saving and Recalling Operating States	43
Turn-On Conditions	43
Setting The GPIB Address	43
Types of Power supply GPIB Addresses	43
Changing the Power supply GPIB Address	44
6 - REMOTE PROGRAMMING	45
Prerequisites for Remote Programming	45
External Documents	45
SCPI References	45

GPIB References	45
GPIB Capabilities of the Power supply	46
Introduction To SCPI	46
Conventions	46
Types of SCPI Commands	46
Traversing the Command Tree	47
Active Header Path	47
The Effect of Optional Headers	47
Moving Among Subsystems	48
Including Common Commands	48
SCPI Queries	48
Value Coupling	48
Types of SCPI Messages	49
Structure of a SCPI Message	49
SCPI Data Formats	51
Numerical Data	51
Boolean Data	51
Character Data	51
SCPI Command Completion	52
Programming Examples	52
Programming Voltage and Current	53
Programming Protection Circuits	53
Changing Outputs by Trigger	53
Saving and Recalling States	54
Writing to the Display	54
Programming Status	54
Detecting Events via SRO	54
Reading Specific Registers	54
Programming the Digital I/O Port	55
System Considerations	55
Setting the GPIB Address	55
Changing the Power supply GPIB Address	55
Assigning the GPIB Address In Programs	56
DOS Drivers	57
Types of Drivers	57
Error Handling	57
Keysight BASIC Controllers	57
Sample Program Code	57
SCPI Confirmed Commands¹	62
NON-SCPI Commands	62

7 - LANGUAGE DICTIONARY

63

Introduction	63
Parameters	63
Related Commands	63
Order of Presentation	63
Common Commands	63
Subsystem Commands	63
Description Of Common Commands	64
*CLS	64
*ESE	65
*ESR?	65
*IDN?	66
*OPC	66
*OPC?	67
*OPT?	67

*RCL	68
*RST	69
*SAV	69
*SRE	70
*STB?	70
*TRG	71
*TST?	71
*WAI	71
Description Of Subsystem Commands	72
ABOR	72
Calibration Commands	72
Current Subsystem	73
CURR CURR:TRIG	73
CURR:PROT:STAT	73
Digital Subsystem	74
DIG:DATA	74
Display Subsystem	74
DISP	74
DISP:MODE	75
DISP:TEXT	75
Initiate Subsystem	76
INIT INIT:CONT	76
Measure Subsystem	76
MEAS:CURR? MEAS:VOLT?	76
Output Subsystem	77
OUTP	77
OUTP:PROT:CLE OUTP:PROT:DEL	77
OUTP:REL	78
OUTP:REL:POL	78
Status Subsystem	78
STAT:PRES	78
Status Operation Registers	79
STAT:OPER?	79
STAT:OPER:COND?	79
STAT:OPER:ENAB	79
STAT:OPER:NTR STAT:OPER:PTR	80
Status Questionable Registers	80
STAT:QUES?	80
STAT:QUES:COND?	81
STAT:QUES:ENAB	81
STAT:QUES:NTR STAT:QUES:PTR	81
System Commands	82
SYST:ERR?	82
SYST:LANG	82
SYST:VERS?	82
Trigger Subsystem	83
TRIG	83
TRIG:SOUR	83
Voltage Subsystem	83
VOLT VOLT:TRIG	83
VOLT:PROT	84
Command Summary	85
Programming Parameters	86

8 - STATUS REPORTING

87

Power supply Status Structure

87

Operation Status Group	87
Register Functions	87
Register Commands	87
Questionable Status Group	89
Register Functions	89
Register Commands	89
Standard Event Status Group	89
Register Functions	89
Register Commands	89
Status Byte Register	90
The MSS Bit	90
The RQS Bit	90
Output Queue	90
Service Request Enable Register	90
Inhibit/Fault Indicator	90
RI (Remote Inhibit)	90
DFI (Discrete Fault Indicator)	90
Initial Conditions At Power On	91
Status Registers	91
The PON (Power-On) Bit	91
Status Register Programming Examples	91
Determining the Cause of a Service Interrupt	91
Servicing an Operation Status Mode Event	92
Adding More Operation Events	92
Servicing Questionable Status Events	92
Monitoring Both Phases of a Status Transition	92

A - SPECIFICATIONS **93**

B - CALIBRATION **97**

Introduction	97
Equipment Required	97
General Procedure	97
Parameters Calibrated	97
Test Setup	97
Front Panel Calibration	98
Entering the Calibration Values	98
Saving the Calibration Constants	98
Disabling the Calibration Mode	98
Changing the Calibration Password	98
Recovering From Calibration Problems	100
Calibration Error Messages	100
Calibration Over The GPIB	100
Calibration Example	100
Calibration Language Dictionary	101
CAL:CURRE	101
CAL:CURRE:LEV	101
CAL:PASS	101
CAL:SAVE	101
CAL:STAT	102
CAL:VOLT	102
CAL:VOLT:LEV	102
CAL:VOLT:PROT	102
BASIC Calibration Program	103

C - VERIFICATION	105
Introduction	105
Test Equipment Required	105
List of Equipment	105
Current Monitoring Resistor	105
Performing The Tests	106
General Measurement Techniques	106
Programming the Power supply	106
Order of Tests	106
Turn-on Checkout	106
Voltage Programming and Readback Accuracy	106
Current Programming and Readback Accuracy	107
D - ERROR MESSAGES	109
Power supply Hardware Error Messages	109
Calibration Error Messages	109
System Error Messages	109
E - LINE VOLTAGE CONVERSION	111
F - DIGITAL PORT FUNCTIONS	113
Digital Connector	113
Fault/Inhibit Operation	113
Changing The Port Configuration	115
Digital I/O Operation	116
Relay Link Operation	116
G - COMPATIBILITY LANGUAGE	119
Introduction	119
Parallel Polling	119
H - SERVICE ADDENDUM	123
Introduction	123
Areas of Difference	123
Chapter 2 Differences	123
Voltage and Current Values – page 2-4	123
Verification Test Record – page 2-19	124
Chapter 3 Differences	125
Initialization Program Listing - page 3-38	125
Chapter 5 Differences	125
INDEX	127
KEYSIGHT SALES AND SUPPORT OFFICES	132
Manual Updates	133

General Information

Introduction

The following Getting Started Map will help you find the information you need to complete the specific task that you want to accomplish. Refer to the table of contents or index of each guide for a complete list of the information contained within.

Table 1-1. Getting Started Map

Task	Where to find information
General information Capabilities and characteristics	Chapter 1
Installing the unit Location Line connections	Chapter 2
Checking out the unit Verifying proper operation Using the front panel	Chapter 3
Making Connections Load connections Computer connections Application Information	Chapter 4
Using the front panel Front panel keys Front panel examples	Chapter 5
Using the programming interface GPIB interface	Chapter 6
Programming the unit using SCPI (and COMPatibility) commands SCPI commands SCPI programming examples SCPI language dictionary	Chapters 7 and 8 for SCPI commands. Appendix G for COMPatibility commands
Installing the Keysight VXI <i>plug&play</i> instrument driver NOTE: The driver must be installed on your pc to access the on-line information. Drivers are available on the web at www.keysight.com/go/drivers .	Chapter 2

Safety Considerations

This power supply is a Safety Class 1 instrument, which means it has a protective earth terminal. That terminal must be connected to earth ground through a power source equipped with a 3-wire ground receptacle. Refer to the Safety Summary page at the beginning of this guide for general safety information. Before installation or operation, check the power supply and review this guide for safety warnings and instructions. Safety warnings for specific procedures are located at appropriate places in the guide.

Options

Table 1-2. List of Options

Option	Description
230	Input power 230 Vac, nominal
200	Input power 200 Vac, nominal
831	Power cord, 12 AWG, UL listed, CSA certified, without plug
832	Power cord, 4 mm ² , harmonized, without plug
834	Power cord, 10 AWG, UL listed, CSA certified, without plug
842	Power cord, 4 mm ² , harmonized, with IEC 309 32A/220V plug
844	Power cord, 10 AWG, UL listed, CSA certified, with NEMA L6-30P-30A/250V locking plug
908	Rack mount kit (Keysight 5062-3977) Support rails (E3663A) are required.
909	Rack mount kit with handles (Keysight 5062-3983) Support rails (E3663A) are required.
0B3	Service addendum

Accessories

Table 1-3. List of Accessories

Description Keysight No.	Keysight No.
GPIB cable (all models)	
0.5 meters (1.6 ft)	10833D
1.0 meter (3.3 ft)	10833A
2.0 meters (6.6 ft)	10833B
4.0 meters (13 .2 ft)	10833C
Serial link cable 2.0 meters (6.6 ft)	5080-2148
Accessory slide mount kit	1494-0059

Operator Replaceable Parts List

Table 1-4. Operator Replaceable Parts List

Description	Keysight Part No.	Description	Keysight Part No.
Cable assembly, GPIB	(see Table 1-3)	Power cord assembly	(see Table 1-2)
Cable assembly, serial link	(see Table 1-3)	Rack mount kit	(see Table 1-2)
Collar, rotary output control	5040-1700	Resistor, calibration	(Appendix B)
Cover, ac input safety	5040- 1676		
Cover, dc output	5040- 1674	Screw, ac input safety cover (M4.0 x 60 mm long)	0515-0156
Flatwasher, ac input safety cover	3050-1053	Screw, carrying strap (M5x0.8x10 mm)	0515-1384
Foot, cabinet	5041-8801		
Fuse, power 25A, 250V (this is an internal fuse).	2110-0849		
Knob, rotary output control	0370-1091	Screw, output bus bar, 1/4-20x1/2	2940-0103
Lockwasher, ac input safety cover	2190-0484	Screw, outer cover, (M5 x 0.8 mm)	0515-0073
Lockwasher, output bus bar, 1/4 spring	3050-1690	Screw, output sense terminal (M3x0.5x8mm)	0515-0104
Keysight 59510/11A Relay Accessories	5957-6382	Slide mount kit	(see Table 1-3)
Keysight Series 667xA Service Manual	5961-2583	Standoff, GPIB	0380-0643
Keysight E4356A Service Addendum	5964-8170		
Nut, output bus bar, hex 1/4-20x1/2	2950-0084	Terminal, crimp, ac power cord	
Nut, power ground, hex w/lw 3/8x32	0590-0305	L or N terminal	0362-0681
Plug, analog connector (7-terminal)	1252-3698	Gnd terminal	0362-0207
Plug, digital connector (4-terminal)	1252-1488		

Description

The Keysight E4356A is a unipolar, GPIB programmable power supply, which is programmable locally from the front panel or remotely via a rear-panel analog control port. Operational features include:

- Constant voltage (CV) or constant current (CC) output over the rated output range.
- Built-in overvoltage (OV), overcurrent (OC), and overtemperature (OT) protection.
- Automatic turn-on selftest.
- Pushbutton nonvolatile storage and recall of up to 5 operating states.
- Local or remote sensing of output voltage.
- Auto-parallel operation for increased total current.
- Series operation for increased total voltage.
- Analog input for remote programming of voltage and current.
- Voltage output for external monitoring of output current.
- User calibration from the front panel.

Front Panel Programming

The front panel has both rotary (RPG) and keypad controls for setting the output voltage and current. The panel display provides digital readouts of the output voltage and current. Other front panel controls permit:

- Enabling or disabling the output.
- Setting the overvoltage protection (OVP) trip voltage.
- Enabling or disabling the overcurrent protection (OCP) feature.
- Saving and recalling operating states.
- Setting the GPIB address.
- Reading GPIB error message codes.
- Calibrating the power supply, including changing the calibration protection password.

Remote Programming

The power supply may be remotely programmed via the GPIB bus and/or from an analog input port. GPIB programming is with SCPI (Standard Commands for Programmable Instruments) commands that make the power supply programs compatible with those of other GPIB instruments. (A software Compatibility mode also permits programming in the command set of the Keysight 6030xA Autoranging Series.) In addition to control functions, SCPI programming permits writing to the front panel LCD and complete calibration functions. Power supply status registers permit remote monitoring of the following conditions:

- Overvoltage, overcurrent, overtemperature, and unregulated states.
- Operating mode (constant voltage or constant current).
- State of the RI (remote inhibit) input signal.
- Power-on status (PON).
- Status of the output queue (QYE).
- Pending triggers (WTG).
- GPIB interface programming errors (CME, DDE, and EXE).
- Calibration state (enabled or disabled).

The status registers can be programmed to generate an output fault signal (FLT) upon the occurrence of one or more selected status events.

Analog Programming

The power supply has an analog port for remote programming. The output voltage and/or current of the power supply may be controlled by individual dc programming voltages applied to this port. The port also provides a monitor output that supplies a dc voltage proportional to the output current.

Output Characteristic

The power supply can operate in either CV (constant voltage) or CC (constant current) over its output voltage and current ratings (see Figure 1-1). Although the power supply can operate in either mode, it is designed as a constant voltage source. This means that the unit turns on in constant voltage mode with the output voltage rising to its V_{set} value. There is no command for constant current operation. The only way to turn the unit on in constant current mode is by placing a short across the output and then enabling or turning the output on.

Note that the power supply cannot be programmed to operate in a specific mode. After initial turn-on, the operating mode of the unit will be determined by the voltage setting (V_s), the current setting (I_s), and the load impedance (R_L). In Figure 1-1, operating point 1 is defined by the load line cutting the operating locus in the constant-voltage region. This region defines the CV mode. Operating point 2 is defined by the load line cutting the operating locus in the constant-current region. This region defines the CC mode.

Appendix A lists the specifications and supplemental characteristics.

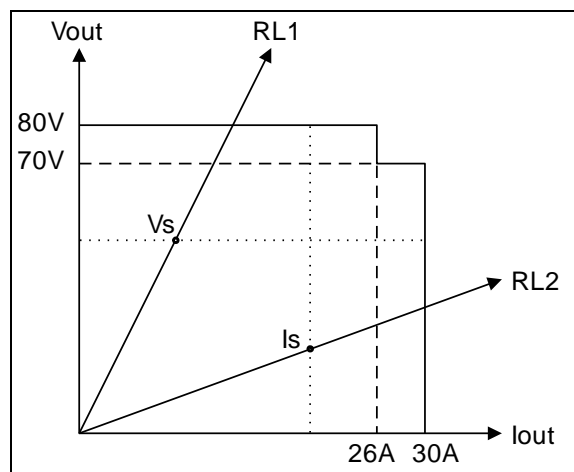

Figure 1-1. Output Characteristic Curve

Output Ranges

Figure 1-1 shows two output ranges: 80V, 26A and 70V, 30A. The step in the output characteristic indicates that the power supply cannot simultaneously output 80V and 30A. No separate command is required to select a range, the power supply automatically selects one of the operating ranges based on the *last* parameter (either voltage or current) that is programmed. For example, if you program 80V and 30A, the power supply will select the 70V, 30A range based on the last parameter that was programmed: 30A.

Downprogramming

The power supply can sink current for more rapid down programming in the CV mode. This is an uncharacterized current-sinking area that provides a limited downprogramming capability.

Installation

Inspection

Damage

When you receive your power supply, inspect it for any obvious damage that may have occurred during shipment. If there is damage, notify the shipping carrier and the nearest Keysight Sales and Support Office immediately. Warranty information is printed in the front of this guide.

Packaging Material

Until you have checked out the power supply save the shipping carton and packing materials in case the power supply has to be returned to Keysight Technologies. If you return the power supply for service, attach a tag identifying the model number and the owner. Also include a brief description of the problem.

Items Supplied

In addition to this manual, check that the following items in Table 2-1 are included with your power supply (see Table 1-6 for part numbers):

Table 2-1. Items Supplied

Power cord	Your power supply was shipped with a power cord appropriate for your location. The cord may or may not be terminated in a power plug (see "Options" in Chapter 1). If the cord is not included, contact your nearest Keysight Sales and Support Office (see end of this guide) to obtain the correct cord. These models also include a power input safety cover with strain relief connector. It is required to secure the power cord to the power supply.
Analog connector	A 7-terminal analog plug (see Table 1-4) that connects to the back of the unit. Analog connections are described in Chapter 4.
Digital connector	A 4-terminal digital plug (see Table 1-4) that connects to the back of the unit. Digital connections are described in "Appendix D - Digital Port Functions"
Serial cable	A 2-meter cable (see "Accessories" in Chapter 1) that connects to the control bus (next to the GPIB connector). This cable is used to serially connect multiple power supplies as described under "Controller Connections" in Chapter 4.
Output hardware	Output hardware (screws with nuts and lockwashers) for securing your load wires to the output bus bars (see Table 1-4).
Guide change page	If applicable, change sheets may be included with this guide. If there are change sheets, make the indicated corrections in this guide.

Location and Temperature

Bench Operation

The Table A-2 in Appendix A gives the dimensions of your power supply. The cabinet has plastic feet that are shaped to ensure self-alignment when stacked with other Keysight System II cabinets. The feet may be removed for rack mounting. Your power supply must be installed in a location that allows sufficient space at the sides and rear of the cabinet for adequate air circulation. Minimum clearances are 1 inch (25 mm) along the sides. Do not block the fan exhaust at the rear of the unit.

Rack Mounting

The power supply can be mounted in a standard 19-inch rack panel or cabinet. Rack mounting kits are available as Option 908 or 909 (with handles). Installation instructions are included with each rack mounting kit.

CAUTION

This power supply requires instrument support rails for non-stationary installations. These are normally ordered with the cabinet and are not included with the rack mounting kits.

Temperature Performance

A variable-speed fan cools the unit by drawing air through the sides and exhausting it out the back. Using Keysight rack mount or slides will not impede the flow of air. The temperature performance is as follows:

The unit operates without loss of performance within the temperature range of 0 °C to 45 °C.

Input Power Source

Do not apply power to the power supply until directed to do so in Chapter 3.

CAUTION

Check the line **Rating** label on the rear of your unit and verify that the voltage shown there corresponds to the nominal line voltage of your power source. If it does not, see Appendix E - "Line Voltage Conversion" for instructions on changing the power supply's line voltage configuration.

Note This product requires single-phase input voltage.

You can operate your unit from a nominal 200 V or a 230 V single-phase power source, or from the line-to-line voltage of a 208-volt, 3-phase source. The proper source is indicated on the rear **Rating** label (4), Figure 2-2). See "AC Input Ratings" in Table A-2 for the voltage and frequency range for each type of power source.

Note The power source must be a dedicated line with no other devices drawing current from it.

The line fuse is located inside the power supply. Table 1-4 identifies the replacement fuse. See "In Case of Trouble" in Chapter 3 for instructions on fuse replacement.

Installing the Power Cord

WARNING

Installation of the power cord must be done by a qualified electrician and in accordance with local electrical codes.

The power cord supplied with power supply may or may not include a power plug (see "Options" in Chapter 1) at one end of the cord. Terminating connections and a ground lug are attached to the other end of the cord. See Figure 2-2 and proceed as follows:

1. If they are not already in place, position the strain relief connector (11), safety cover (5), rubber boot (9), and connector nut (8) on the power cord (7).
2. Secure the ground wire (2) to the chassis earth ground stud.
3. For single-phase operation, connect the neutral wire (1) to the N input terminal and the line wire (3) to the L input terminal (this line is fused inside the unit).
4. For line-to-line operation from a three-phase source as shown in Figure 2-3, connect one phase to the N input terminal and another phase to the L input terminal (this line is fused inside the unit).

Note The N terminal is not internally grounded.

5. Position the safety cover over the power input terminals and tighten the cover screws (10) and strain relief connector screws (6).

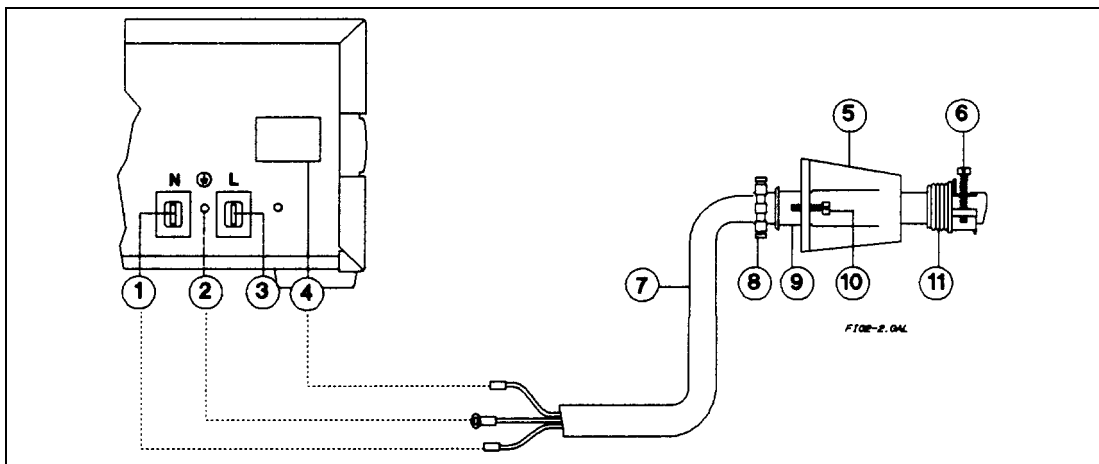

Figure 2-2. Connecting Power Cord

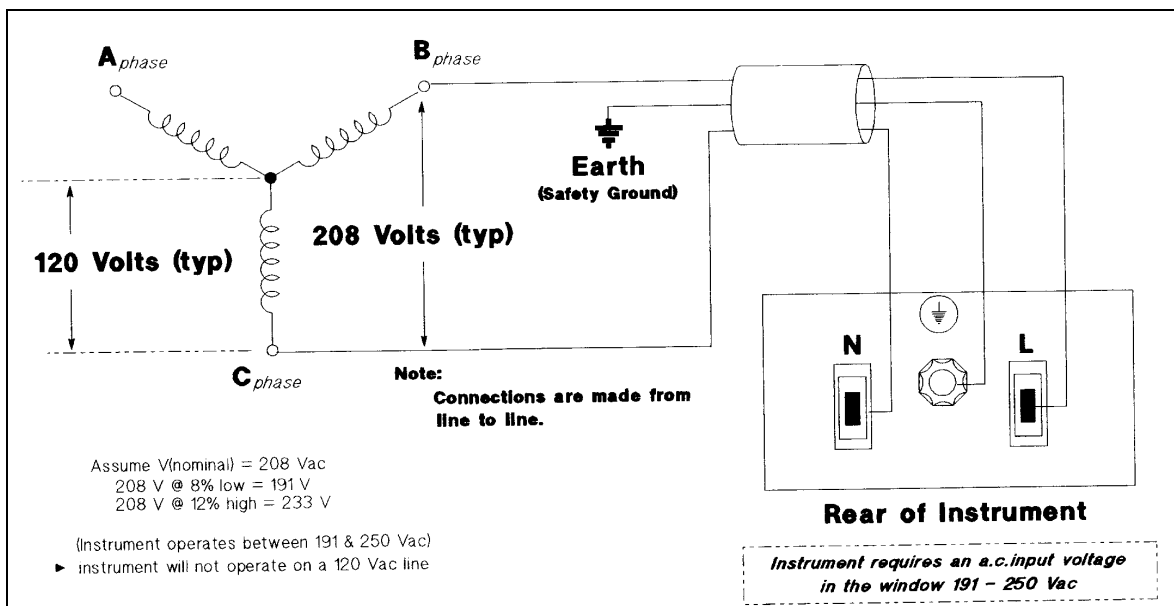

Figure 2-3. Connection to a 3-Phase Line

VXI *plug&play* Power Products Instrument Drivers

VXI *plug&play* Power Products instrument drivers for Microsoft Windows 95 and Windows NT are now available on the Web at <http://www.keysight.com/find/drivers>. These instrument drivers provide a high-level programming interface to your Keysight Power Products instrument. VXI *plug&play* instrument drivers are an alternative to programming your instrument with SCPI command strings. Because the instrument driver's function calls work together on top of the VISA I/O library, a single instrument driver can be used with multiple application environments.

Supported Applications

- Keysight VEE
- Microsoft Visual BASIC
- Microsoft Visual C/C++
- Borland C/C++
- National Instruments LabVIEW
- National Instruments LabWindows/CVI

System Requirements

The VXI *plug&play* Power Products instrument driver complies with the following:

- Microsoft Windows 95
- Microsoft Windows NT 4.0
- HP VISA revision F.01.02
- National Instruments VISA 1.1

Downloading and Installing the Driver

NOTE: Before installing the VXI *plug&play* instrument driver, make sure that you have one of the supported applications installed and running on your computer.

1. Access Keysight Technologies' Web site at <http://www.keysight.com/find/drivers>.
2. Select the instrument for which you need the driver.
3. Click on the driver, either Windows 95 or Windows NT, and download the executable file to your pc.
4. Locate the file that you downloaded from the Web. From the **Start** menu select **Run** <path>:\agxxxx.exe - where <path> is the directory path where the file is located, and agxxxx is the instrument driver that you downloaded .
5. Follow the directions on the screen to install the software. The default installation selections will work in most cases. The readme.txt file contains product updates or corrections that are not documented in the on-line help. If you decide to install this file, use any text editor to open and read it.
6. To use the VXI *plug&play* instrument driver, follow the directions in the VXI *plug&play* online help under "Introduction to Programming".

Accessing Online Help

A comprehensive online programming reference is provided with the driver. It describes how to get started using the instrument driver with Keysight VEE, LabVIEW, and LabWindows. It includes complete descriptions of all function calls as well as example programs in C/C++ and Visual BASIC.

- To access the online help when you have chosen the default Vxipnp start folder, click on the Start button and select Programs | Vxipnp | Agxxxx Help (32-bit).
- where Agxxxx is the instrument driver.

Turn-On Checkout

Introduction

Note This chapter provides a preliminary introduction to the power supply front panel. See Chapter 5 - "Front Panel" for more details.

Successful tests in this chapter provide a high degree of confidence that the power supply is operating properly. For verification tests, see Appendix C - "Operation Verification". Complete performance tests are given in the service manual.

Do not apply ac power to the power supply until told to do so.

Preliminary Checkout

1. Make certain that the front panel switch is off.
 2. Examine the Line Voltage Rating or Line And Fuse Rating label (see Chapter 2 - "Installation")
Verify that the line voltage rating agrees with your power source. If it does not, see Appendix E - "Line Voltage Conversion".
 3. Check the sense wiring as follows:
Remove the output safety cover and examine the output sense terminals. They should be wired for local sensing as follows:
 1. The **+LS** sense terminal wired to the **+S** terminal of the analog connector.
 2. The **-LS** sense terminal wired to the **-S** terminal of the analog connector.
 3. If the power supply is not wired for local sensing, make the above connections, using small-capacity wire (AWG #22 is sufficient).
 4. Make sure that there is no load connected to the output terminals or bus bars.
-

Power-On Checkout

1. Connect the power cord to the power supply .
 2. Turn the front panel power switch to ON (1).
 3. The power supply undergoes a self-test when you turn it on. If the test is normal, the following sequence appears on the LCD:
The GPIB address (factory default is 5).
This is then followed by **PWR ON INIT** for approximately 10 seconds.
 4. The display then goes into the meter mode with the **Dis** annunciator on and all others off. "Meter mode" means that the **VOLTS** digits indicate the output voltage and the **AMPS** digits indicate the output current. These values will be at or near zero.
 5. Verify that the power supply fan is on by placing your hand near the rear grill to feel the air flow. You may also be able to hear the fan operating.
 6. Press **Output on/off** once. The **Dis** annunciator will go off and the CV annunciator will go on .
-

Note If the power supply detects an error during self-test, the display will show an error message. Go to "In Case of Trouble" at the end of this chapter.

Using the Keypad

Shifted Keys

Some of the front panel keys perform two functions, one labeled in black and the other in blue. You access the blue function by first pressing the blue **Shift** key, which is not labeled. When the **Shift** annunciator is on, you will know you have access to the key's shifted (blue) function.

Backspace Key

The **←** key is an erase key. If you make a mistake entering a number and have not yet entered it (have not pressed **Enter**), you can delete the number by pressing **←**. You may delete as many numbers as you wish by repeatedly pressing this key.

Output Checkout

Important When the power supply is turned on, it asserts the state stored in EEPROM memory location 0. For a new unit, this is the factory default (*RST) state. The following procedures assume that the factory default state is still in location 0 (**Turn-On Conditions** in Chapter 5 for details).

Checking the Voltage Function

The tests in Table 3-1 check the basic voltage functions with no load connected to the power supply. The **VOLTS** display will show various readings. Ignore the **AMPS** display.

Table 3-1. Checking the Voltage Functions (Output Terminals Open)

Procedure	Display	Explanation
Output Terminals Open or Connected to a Voltmeter		
If Dis is on, turn it off by pressing Output on/off		
Press Voltage key	VOLT 0.000	Default voltage setting. CV annunciator should be on. (If CC annunciator is on, increase the current by pressing ↑Current one or more times until CC turns off and CV turns on.)
Press 4 0	VOLT 40	Program output to 40 volts.
Press Enter	40.00	Enter the voltage. Meter mode displays output voltage. During these tests, there may be a small (relative to full output) AMPS reading that will be ignored.
Press ↓Voltage several times		Voltage decreases several millivolts each time you press the key.*
Press ↑Voltage the same number of times		Voltage increases several millivolts each time you press the key.*
Rotate Voltage control first counterclockwise and then clockwise		* The number of millivolts change is determined by the voltage programming resolution of your power supply (see Appendix A - "Supplemental Characteristics"). Control operates similarly to ↓Voltage and ↑Voltage keys. The control is rate sensitive. Turning it more quickly causes a more rapid change in voltage.
Press Voltage 4 0 Enter	40.00	Program output to 40 volts.
Press OV		Display shows default OVP (overvoltage protection) trip voltage for your unit (see Appendix A - "Supplemental Characteristics").

Press 3 0	OV 30	Program the OVP to 30 volts, which is less than the output voltage.
Press Enter	0.000	OVP voltage entered is less than the output voltage. This causes the OVP circuit to trip. The output drops to zero, CV turns off, and Prot turns on.
Press Protect	OV - - - -	Shows that the power supply shuts down because the OVP circuit has tripped.
Press ←		Return display to meter mode (optional step).
Press OV 4 5 Enter	0.000	Program the OVP to 45 volts, which is greater than the output voltage. Note: You cannot clear an OVP trip until you have first removed the cause of the condition.
Press Prot Clear (Shift Protect)*	40.00	The OVP circuit is cleared, restoring the output. Prot turns off and CV turns on.
* Shift is the unlabeled blue key.		

Checking the Current Function

The tests in Table 3-2 check the basic current functions with a short connected across the power supply output. **Do not program maximum output currents unless the shorting wire is capable of handling the current** (see "Supplemental Characteristics" and Table 4-2). The **AMPS** display will show various readings. Ignore the **VOLTS** display.

Table 3-2. Checking the Current Functions (Output Terminals Shorted)

Procedure	Display	Explanation
Turn off the power supply and connect a #14 AWG or larger wire across the output (+) and (-) terminals. If you intend to test at full-rated output current, use a wire or wires of sufficient size to carry the maximum current of the unit (see "Supplemental Characteristics" in Chapter 1 and Table 4-2 in Chapter 4).		
Turn on the unit.	Meter mode	Essentially zero output with Dis annunciator on.
Press Voltage 8 0 Enter	VOLT 80.00	Program output to 80 volts.
Press Current 1 Enter	CURR 1.000	Program output to 1 ampere.
Press Output on/off	1.000	Dis annunciator turns off, CC annunciator turns on, and AMPS display shows the programmed current.
Press ↓Current several times		*Current decreases several milliamperes each time you press the key.
Press ↑Current the same number of times		*Current increases several milliamperes each time you press the key.
Rotate the Current control counterclockwise and then clockwise		*The number of milliamperes is determined by the current programming resolution of the power supply (see "Supplemental Characteristics" in Chapter 1). Control operates similarly to the ↓Current and ↑Current keys. The control is rate sensitive. Turning it more quickly causes a more rapid change in current.
Press OCP		You have enabled the overcurrent protection circuit. The circuit then tripped because of the output short. The CC annunciator turns off and the OCP and Prot annunciators come on. Output current is near zero.

Press Output on/off		Dis annunciator turns on.
Press OCP		You have disabled the overcurrent protection circuit. The OCP annunciator turns off.
Press Prot Clear (Shift) Protect)**		You have cleared the overcurrent protection circuit. The Prot annunciator turns off.
Press Output on/off		Dis turns off and CC turns on. The output current is restored.
If you have a shorting wire of sufficient capacity , you may continue testing up to the maximum rated current of the power supply (see "Performance Specifications"). When finished, go to the next step.		
Press Output on/off		Dis turns on and output current drops to zero.
Turn off the power supply and remove the short from the output terminals.		

Checking The Save And Recall Functions

Keysight E4356A power supplies have five nonvolatile memory storage locations (0 through 4). Proceed as follows:

- Make certain that the output is on (**Dis** annunciator is off).
- Set the voltage output to 5 by pressing **Voltage 5 Enter**.
- Save this value to location 1 by pressing **Shift Save 1 Enter**.
- Return the output voltage to 0 by pressing **Recall 0 Enter** (This step is based on the fact that a newly shipped power supply has the *RST parameters stored in location 0 (see "Chapter 5 - Front Panel" for more information).
- Press **Recall 1 Enter** and notice that the output voltage returns to the value stored in location 1.

Determining The GPIB Address

When the power supply is turned on, the display shows ADDR n, where n is the power supply GPIB address. Any time you want to see the address, press **Address**.

The display will indicate **ADDR 5**, which is the factory default. If the address has been changed, then a different number will appear (see "Setting the GPIB Address" in "Chapter 5 - Front Panel").

In Case Of Trouble

Line Fuse

If the power supply appears "dead" with a blank display and the fan not running, first check your power source to be certain line voltage is being supplied to the power supply. If the power source is normal, the power supply line fuse may be defective. If the unit has a defective fuse, replace it only once. If it fails again, investigate the reason for the failure. Proceed as follows:

WARNING

Hazardous voltage can remain inside the power supply even after it has been turned off. Fuse replacement should be done only by qualified electronics personnel.



The line fuse is located inside the power supply. To change it, proceed as follows:

1. Turn off the front panel power switch and unplug the line cord from the power source.
2. Remove the power supply dustcover as follows:
 - a. Remove the four screws securing the carrying straps and dustcover.
 - b. Spread the bottom rear of the dustcover and pull it back to disengage it from the front panel.
 - c. Slide the dustcover back far enough to expose the line fuse (1).
3. Observe the input rail LED under the RFI shield (see Figure E-3 in Appendix E). **If the LED is on, there is still hazardous voltage inside the unit.** Wait until the LED goes out (this may take several minutes) before proceeding.
4. Connect a dc voltmeter across test points TP1 and TP2 (Figure E-3). It may be necessary to remove the RFI shield in order to reach these test points. (The shield is secured by four screws on each side.) When the voltmeter indicates 60 volts or less, it is safe to work inside the power supply.
5. Replace the fuse with one of the same type (see Table 1-4 in Chapter 1). **Do not use a slow-blow type fuse.**
6. If you removed it in step b, be sure to replace the RFI shield.
7. Replace the dust cover.
8. Connect the line cord to the power source.
9. Turn on the front panel power switch and check the operation.

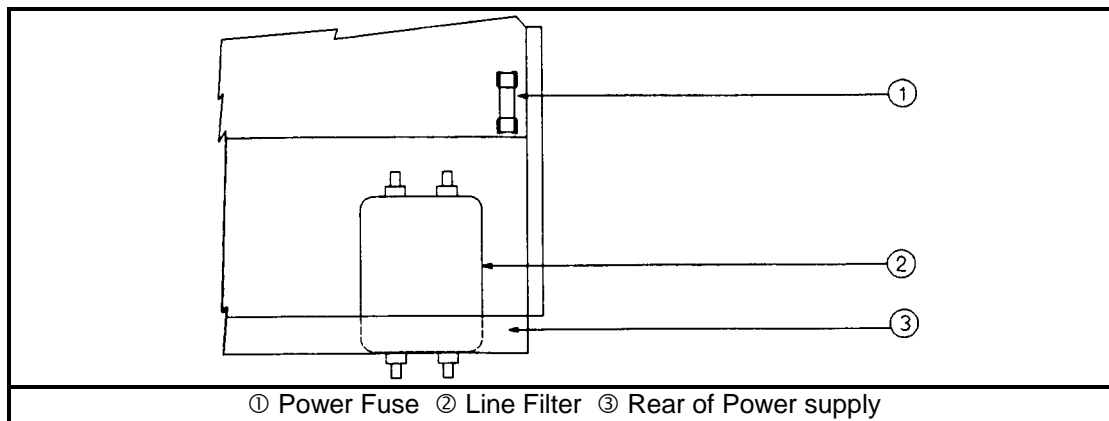

Figure 3-1. Line Fuse Location

Error Messages

Power supply failure may occur during power-on selftest or during operation. In either case, the display may show an error message that indicates the reason for the failure.

Selftest Errors

When a selftest error occurs, it prevents all front panel operation. The display may show either a power-on error message or a checksum error message.

Power-On Error Messages

Power-on messages appear as:

En- - - - -

Where "n" is a number listed in Table 3-3. If this occurs, turn the power off and then back on to see if the error persists. It is possible to recover from the EE CHKSUM error (see "Checksum Errors"). If any other message persists, the power supply requires service.

Table 3-3. Power-On Selftest Errors

Error No.	Display	Failed Test	Error No.	Display	Failed Test
E1	FP RAM	Front Panel RAM	E8	SEC RAM	Secondary RAM
E2	FP ROM	Front Panel ROM checksum	E9	SEC ROM	Secondary ROM checksum
E3	EE	EEPROM	E10	SEC 5V	Secondary 5 V ADC reading
	CHKSUM		E11	TEMP	Secondary ambient thermistor reading
E4	PRI XRAM	Primary external RAM	E12	DACS	Secondary VDAC/IDAC readback
E5	PRI IRAM	Primary internal RAM			
E6	PRI ROM	Primary ROM checksum			
E7	GPIB	GPIB R/W to serial poll			

Checksum Errors.

If the display shows **EE CHKSUM**, the power supply has detected an EEPROM checksum error. A checksum error can occur due to the following conditions:

- Excessive number of write cycles to an EEPROM (see "Nonvolatile Memory Write Cycles" in "Supplemental Characteristics" tables). This condition, which would appear only after extended use, is not recoverable and requires service.
- Loss of ac input power during a checksum calculation. This condition, which is very unlikely, is recoverable.

You may be able to recover from a checksum error by writing to the EEPROM while the power supply is in the calibration mode. To do this, proceed as follows:

1. Enable the calibration mode by pressing **Shift Cal Enable 1 Enter**.
2. **PASWD** will appear on the display.
3. Press the number keys corresponding to the password, followed by **Enter**. The **Cal** annunciator will go on.

Note On new equipment, the calibration password corresponds to the four-digit model number (such as **6651**). See "Appendix A - Calibration" for more information about the calibration password.

4. Save any operating state (for example, press **Shift Save 0 Enter**).
5. Turn the power off and then back on.

A normal display free of error messages should appear. If not, the power supply requires service.

Runtime Error Messages

Under unusual operating conditions, the **VOLT** or **AMPS** display may show **+OL** or **-OL**. This indicates that the output voltage or current is beyond the range of the meter readback circuit. Table 3-4 shows other error messages that may appear at runtime.

Table 3-4. Runtime Errors

Display	Meaning	Display	Meaning
EE WRITE ERR	EEPROM status timeout	UART FRAMING	UART byte framing error
SBUB FULL	Message too long for buffer	UART OVERRUN	Overfilled UART receive buffer
SERIAL DOWN	Failed communication with front	UART PARITY	UART byte parity error panel
STK OVERFLOW	Front panel stack overflow		

User Connections

Rear Panel Connections

Make application load connections to the output terminals or bus bars, analog connector, and digital connector as shown on the rear-panel drawing for your model power supply. Make controller connections (GPIB and serial link) as shown in Figure 4-6 at the end of this chapter.

Load Wire Selection

WARNING

Fire Hazard To satisfy safety requirements, load wires must be large enough not to overheat when carrying the maximum short-circuit current of the power supply. If there is more than one load, then any pair of load wires must be capable of safely carrying the full-rated current of the unit.

Table 4-1 lists the characteristics of AWG (American Wire Gauge) copper wire.

Table 4-1. Stranded Copper Wire Capacity and Resistance

AWG No.	Ampacity ¹	Resistance ² (Ω/m)	AWG No.	Ampacity ¹	Resistance ² (Ω/m)
14	25	0.0103	8	60	0.0025
12	30	0.0065	6	80	0.0016
10	40	0.0041	4	105	0.0010

NOTES:

- Ampacity is based on 30 °C ambient temperature with conductor rated at 60 °C. For ambient temperature other than 30 °C, multiply the above ampacities by the following constants:

Temp (°C)	Constant	Temp (°C)	Constant
21-25	1.08	41-45	0.71
26-30	1.00	46-50	0.58
31-35	0.91	51-55	0.41
36-40	0.82		
- Resistance is nominal at 75 °C wire temperature.

Analog Connector

This connector, which is on the rear panel, is for connecting remote sense leads, external current monitors, and external programming sources. The connector accepts wires sizes from AWG 22 to AWG 12.

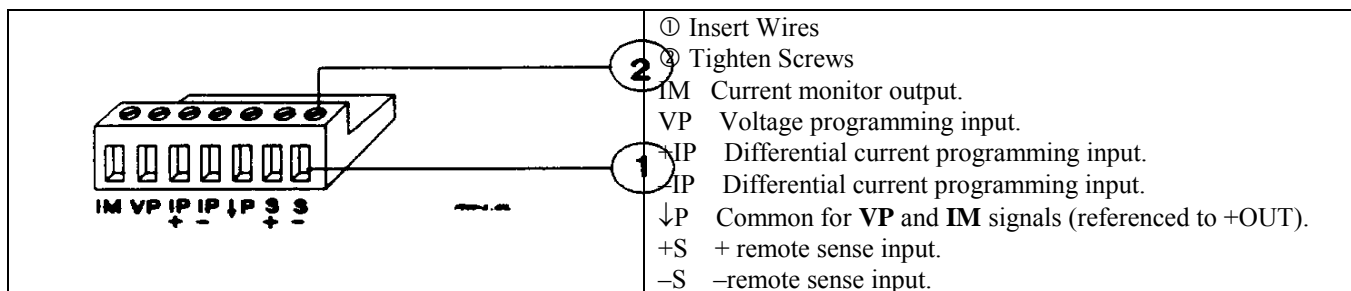

Figure 4-1. Rear Panel Analog Connector

Note It is good engineering practice to twist and shield all signal wires to and from the analog and digital connectors

Digital Connector

This connector, which is on the rear panel, is for connecting fault/inhibit, digital I/O, or relay link signals. The connector accepts wires sizes from AWG 22 to AWG 12.

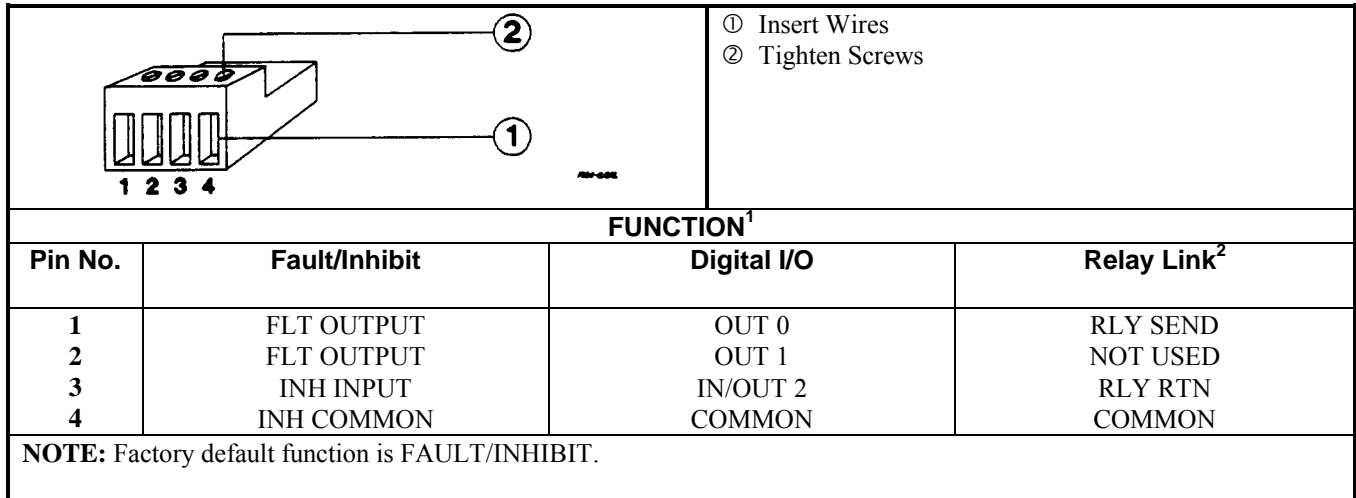

Figure 4-2. Rear Panel Digital Connector

Connecting the Power supply to the Load

Output Isolation

The output of the power supply is isolated from earth ground. Either output terminal may be grounded, or an external voltage source may be connected between either output and ground. However, both output terminals must be kept within ± 240 Vdc of ground. An earth ground terminal is provided on the rear panel for convenience, such as grounding wire shields.

WARNING

The earth ground terminal on the rear panel is a low-noise signal ground for convenience only. It is not designed to function as a safety ground.

Capacitive Loads

In most cases, the power supply will continue to be stable with additional external load capacitors. However, large load capacitors may cause ringing in the unit's transient response. It is possible that certain combinations of load capacitance, equivalent series resistance, and load lead inductance will result in instability. If you need help in solving a stability problem, contact a Keysight service engineer through your local Sales and Support Office (see end of this guide).

If the power supply output is rapidly programmed into capacitive loads, the unit may momentarily cross into constant current (CC) mode. This extends the CV programming time and limits the maximum slew rate to the programmed current divided by the total internal and external capacitance. These momentary crossovers into CC mode will not damage the unit.

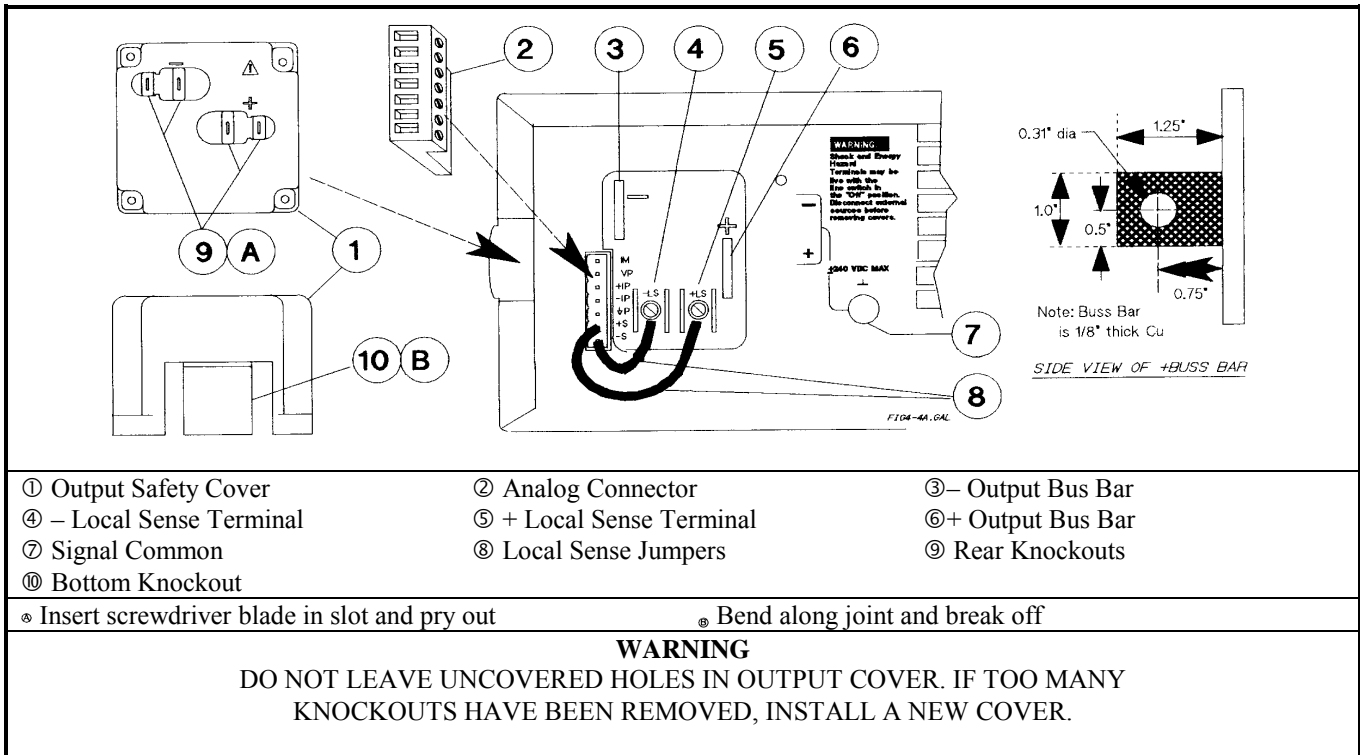

Figure 4-3. Rear Panel Output Connections

Inductive Loads

Inductive loads provide no loop stability problems in CV mode. However, in CC mode inductive loads will form a parallel resonance network with the power supply's output capacitor. Generally, this will not affect the stability of the unit, but it may cause ringing of the current in the load. Ringing will not occur if the Q (quality factor) of the parallel resonant network is ≤ 1.0 . Use the following formula to determine the Q of your output.

$$Q = \frac{1}{R_{int} + R_{ext}} \sqrt{\frac{L}{C}}$$

where: C = model-dependent internal capacitance (see below); L = inductance of the load; R_{ext} = equivalent series resistance of the load; R_{int} = model-dependent internal resistance (see below):

$$C = 7,000 \mu\text{F}$$

$$R_{int} = 14 \text{ m}\Omega$$

If the Q is greater than 0.5, inductive loads will ring with the output capacitance and will be damped according to the following equation:

$$\left[e \left(\frac{-i}{2Q} \right) \sin \omega t \sqrt{1 - \left(\frac{1}{2Q} \right)^2} \right]$$

Battery Charging

The power supply's OVP circuit has a downprogrammer FET that discharges the power supply output whenever OVP trips. If a battery (or other external voltage source) is connected across the output and the OVP is inadvertently triggered or the output is programmed below the battery voltage, the power supply will sink current from the battery. To avoid this, insert a reverse blocking diode in series with the \oplus output of the unit. Connect the diode cathode to the + battery terminal and the diode anode to the \oplus output terminal of the unit. The diode may require a heat sink.

Local Voltage Sensing

Your power supply was shipped set up for local sensing. This means that the unit will sense and regulate its output at the output terminals, not at the load. Since local sensing does not compensate for voltage drops across screw terminals, bus bars, or load leads, local sensing should only be used in applications that require low output current or where load regulation is not critical.

Local sensing is obtained by connecting the **+LS** sense terminal to the **+S** analog connector pin and the pin and the **-LS** sense terminal to the **-S** analog connector pin. The power supply is shipped with these connections made.

Note If the sense terminals are left unconnected, the voltage at the bus bars will increase approximately 3 to 5% over the programmed value. Since it is measured at the sense terminals, the voltage readback will not reflect this increase.

Remote Voltage Sensing

The dashed lines in the wiring diagrams illustrate remote voltage sensing. The remote sense terminals of the power supply are connected directly to the load rather than to the output terminals. This allows the unit to automatically compensate for the voltage drop in the load leads as well as to accurately read back the voltage directly across the load.

Setting Up Remote Sense Operation

Remote sensing is obtained by removing the jumpers connecting the **+LS** sense terminal to the **+S** analog connector pin and the **-LS** sense terminal to the **-S** analog connector pin. The power supply is shipped with these jumpers connected.

Connecting the Sense Leads

You must connect the positive side of the load to the **+S** analog connector pin and the negative side of the load to the **-S** analog connector pin (see Figure 4-1). Connect the sense leads carefully so that they do not become open-circuited. If sense leads are left open during operation, the unit will regulate at the output terminals instead of at the load. Remember to bundle or tie wrap the load leads to minimize inductance and reduce noise pickup.

CV Regulation

The voltage load regulation specification in Table A-1 applies at the output terminals of the power supply. When remote sensing, this specification must be compensated. Add an increment to the voltage load regulation specification as specified by “ ΔmV ” in the equation given under *Load regulation* in Table A-2.

Output Rating

The rated output voltage and current specification in Table A-1 applies at the output terminals of the power supply. With remote sensing, any voltage dropped in the load leads causes the unit to increase the voltage at the output terminals so it can maintain the proper voltage at the load. When you attempt to operate at the full-rated output at the load, this forces the voltage at the output terminals to exceed the unit's rated output. This will not damage the unit, but may trip the OVP (overvoltage protection) circuit, which senses the voltage at the output bus bars. When operated beyond its rated output, the unit's performance specifications are not guaranteed, although typical performance may be good. If the excessive demand on the unit forces it to lose regulation, the **Unr** annunciator will indicate that the output is unregulated.

Output Noise

Any noise picked up on the sense leads also appears at the output of the power supply and may adversely affect the load voltage regulation. Be sure to twist the sense leads to minimize external noise pickup and route them parallel and close to the load leads. In noisy environments, it may be necessary to shield the sense leads. Ground the shield only at the power supply. *Do not use the shield as one of the sense conductors.*

Note The signal ground binding post on the rear panel is a convenient place to ground the sense shield.

OVP Considerations

The OVP circuit senses the voltage near the output terminals and not at the sense terminals. Depending on the voltage drop between the output terminals and the load, the voltage sensed by the OVP circuit can be significantly higher than actually being regulated at the load. You must program the OVP trip high enough to compensate for the expected higher voltage at the output terminals.

Stability

Using remote sensing under unusual combinations of load-lead lengths and large load capacitances may cause your application to form a low-pass filter that becomes part of the voltage feedback loop. The extra phase shift created by this filter can degrade the unit's stability and result in poor transient response. In severe cases, this may cause output oscillations. To minimize this possibility, keep the load leads as short as possible and tie wrap them together.

In most cases, following the above guidelines will prevent problems associated with load lead inductance. However, if a large bypass capacitor is required at the load and load-lead length cannot be reduced, then a sense-lead bypass network may be needed to ensure stability (see Figure 4-4). The voltage rating of the 33 μF capacitors should be about 50% greater than the anticipated load-lead drop. Addition of the 20- Ω resistors will cause a slight voltage rise at the remote sensing points. For utmost voltage programming accuracy, the unit should be recalibrated with the DVM at the remote sensing points (see "Appendix B - Calibration").

Note If you need help in solving a stability problem with the power supply, contact a Keysight Service Engineer through your local Keysight Sales and Support Office.

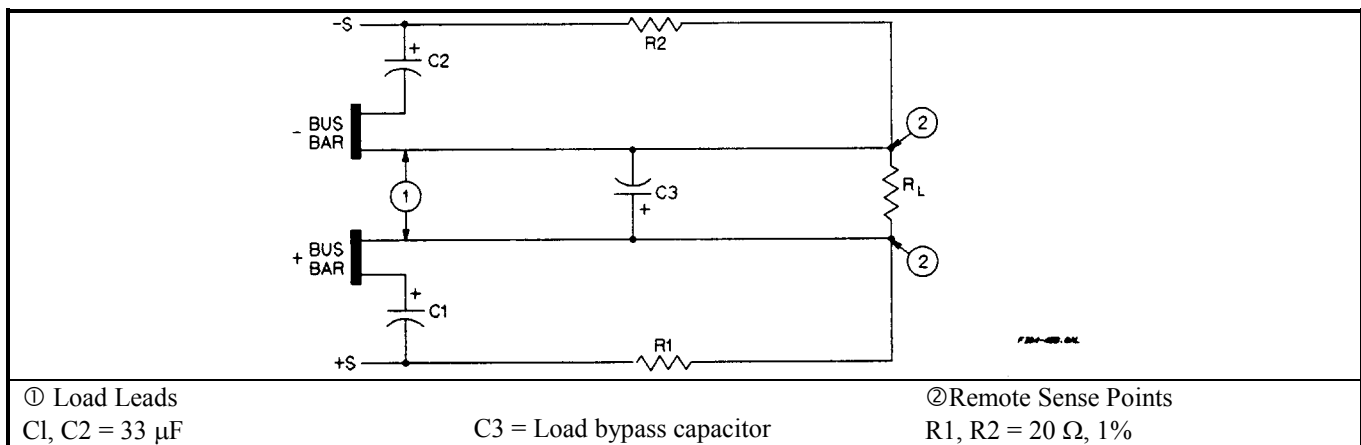

Figure 4-4. Sense Lead Bypass Network

Operating Configurations

Figures 4-5 through Figure 4-8 show the various configurations for connecting to the load. Figure 4-9 shows how to connect an external voltage source for analog programming.

Connecting One Power supply to a Single Load

Figure 4-5 shows how to connect a single power supply to one load. Keep output load leads close together (small loop area) to obtain a low inductance and low impedance connection to the load. If you wish to use remote sensing, connect the sense leads at the load as shown in the figures.

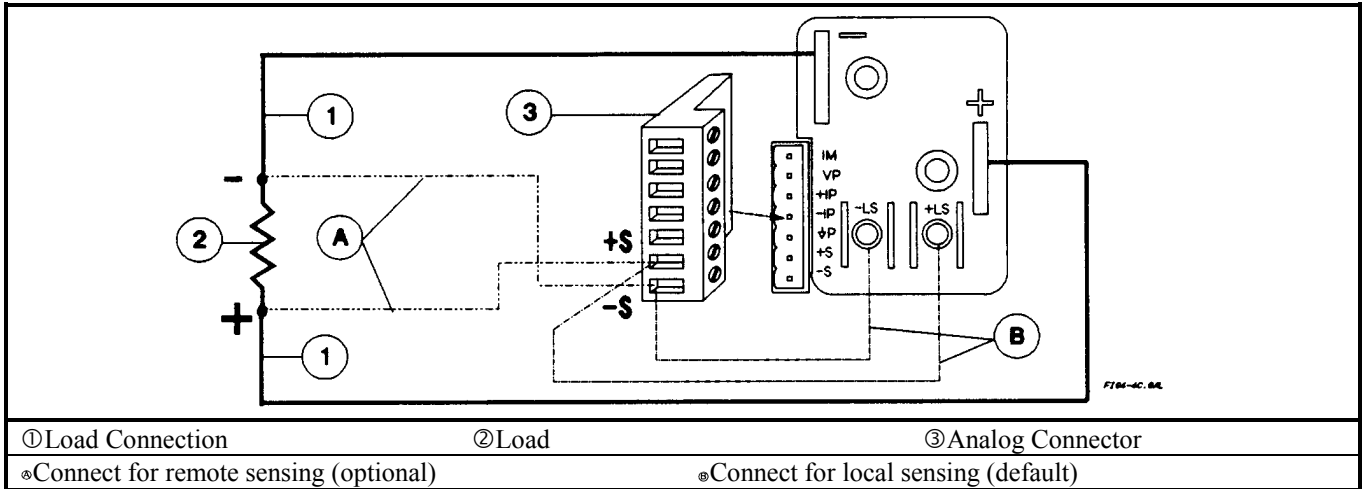

Figure 4-5. Single Load Connection (Remote Sensing Optional)

Connecting One Power supply To Multiple Loads

Figure 4-6 shows how to connect a single power supply to more than one load. When connecting multiple loads to the power supply with local sensing, connect each load to the output bus bars with separate connecting wires. This minimizes mutual coupling effects and takes full advantage of the unit's low output impedance. Keep each pair of load wires as short as possible and twist or bundle them to reduce lead inductance and noise pickup.

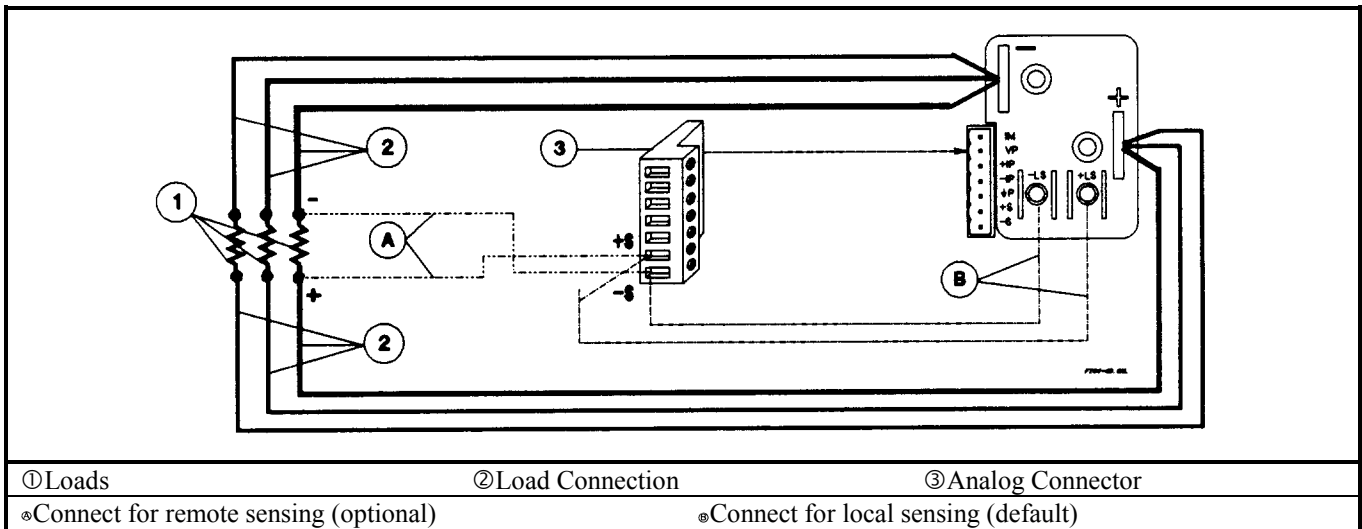

Figure 4-6. Multiple Load Connection (Remote Sensing Optional)

Connecting Units in Auto-Parallel

Figure 4-7 illustrates how power supplies can be connected in auto-parallel for increased current output. You can connect up to five units of the *same model*.

Use load leads of a sufficient wire size so that the absolute voltage difference between the + output terminal of the "master" unit and the + output terminal of the first "slave" unit is kept under 2 V at rated current. This also applies to the voltage difference between the + output terminals of the first and second slave units. If remote sensing is required, connect the load to the remote sense terminals *of the master unit*, as shown by the dashed lines in Figure 4-7.

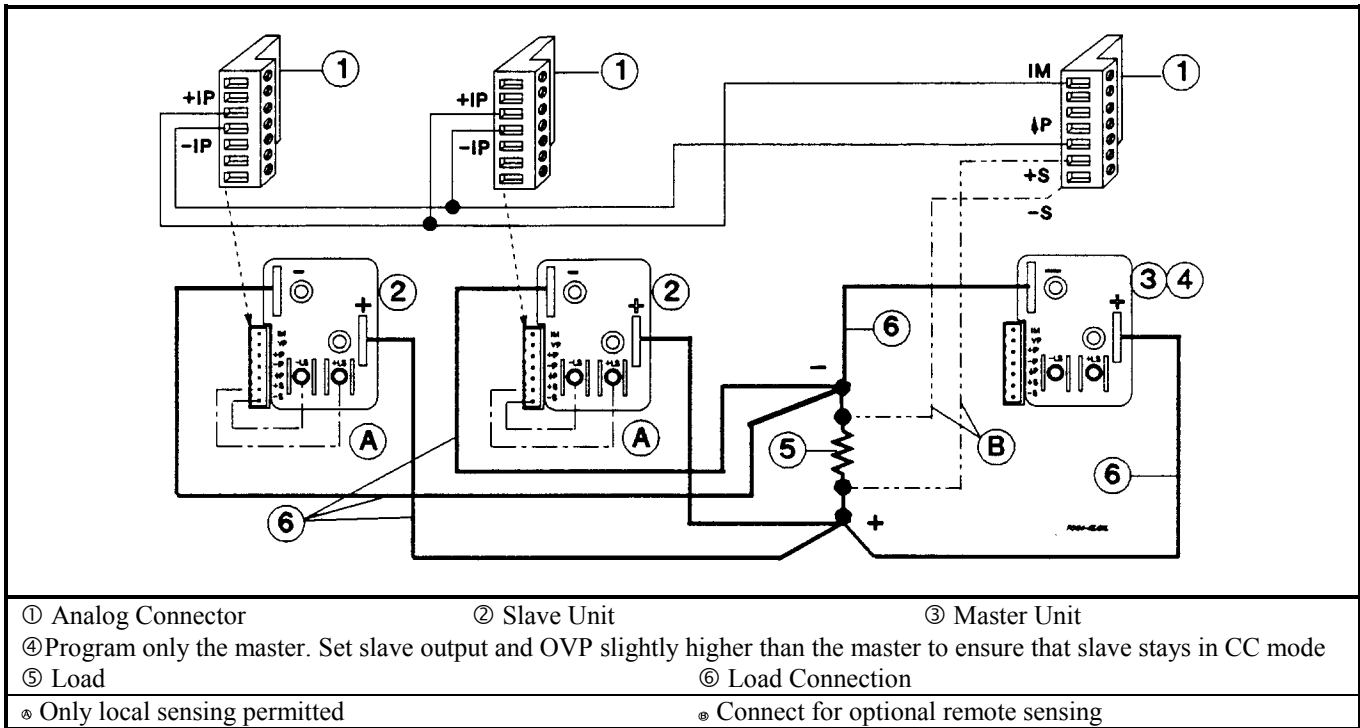

Figure 4-7. Auto-Parallel Connection (Remote Sensing Optional)

Auto-Parallel Programming. Program only the first ("master") unit in the series; the "slave" units automatically track the master's output. However, the voltage and OVP settings of the slave units must be set higher than the operating voltage of the master unit. This ensures that the slave units will operate in CC mode. Functions such as status, voltage readback, and current readback can still be read back individually for each unit.

If a "slave" unit experiences a desired shutdown condition (such as overtemperature or overcurrent), it will not automatically shut down all other units. You must first enable remote inhibit (RI) and discrete fault indicator (DFI) operation. See "Fault/Inhibit Operation" in Appendix F for wiring information and "Questionable Status Group" in Chapter 8 for programming information.

Connecting Units in Series

WARNING

Floating voltages must not exceed 240 Vdc. No output terminal may be more than 240 V from chassis ground.

Figure 4-8 shows how power supplies can be connected in series for higher voltage output. Series connections are straightforward in this case.

Program each power supply independently. If two units are used in the series configuration, program each unit for 50% of the total output voltage. Set the current limit of each unit to the maximum that the load can handle without damage.

CAUTION

Each power supply has a reverse voltage protection diode across its output. If a reverse voltage is applied, the unit cannot control the current conducted through this diode. To avoid damaging the unit, never connect it in such a way that a reverse voltage can force it to conduct current in excess of the unit's maximum reverse diode current (see Table A-2).

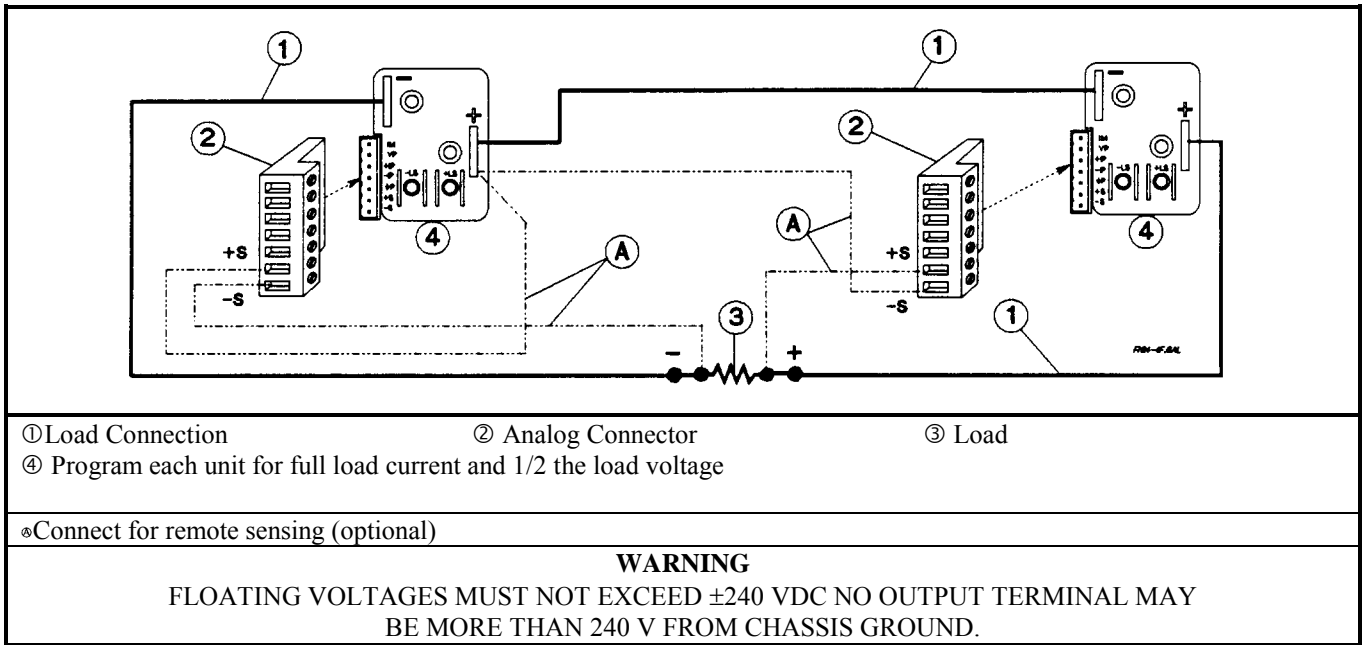

Figure 4-8. Series Connection (Remote Sensing Optional)

External Voltage Control

The setup shown in Figure 4-9 allows an external dc voltage to program the power supply output. A voltage applied to the voltage programming input programs the output voltage and a voltage applied to the current programming input programs the output current. See Figure 4-1 for an explanation of these programming input connections.

Wiring Considerations. The input impedance of the analog input is over 30 k Ω . If the output impedance of your programming source is not negligible with this, programming errors will result. Larger output impedances result in proportionally greater errors.

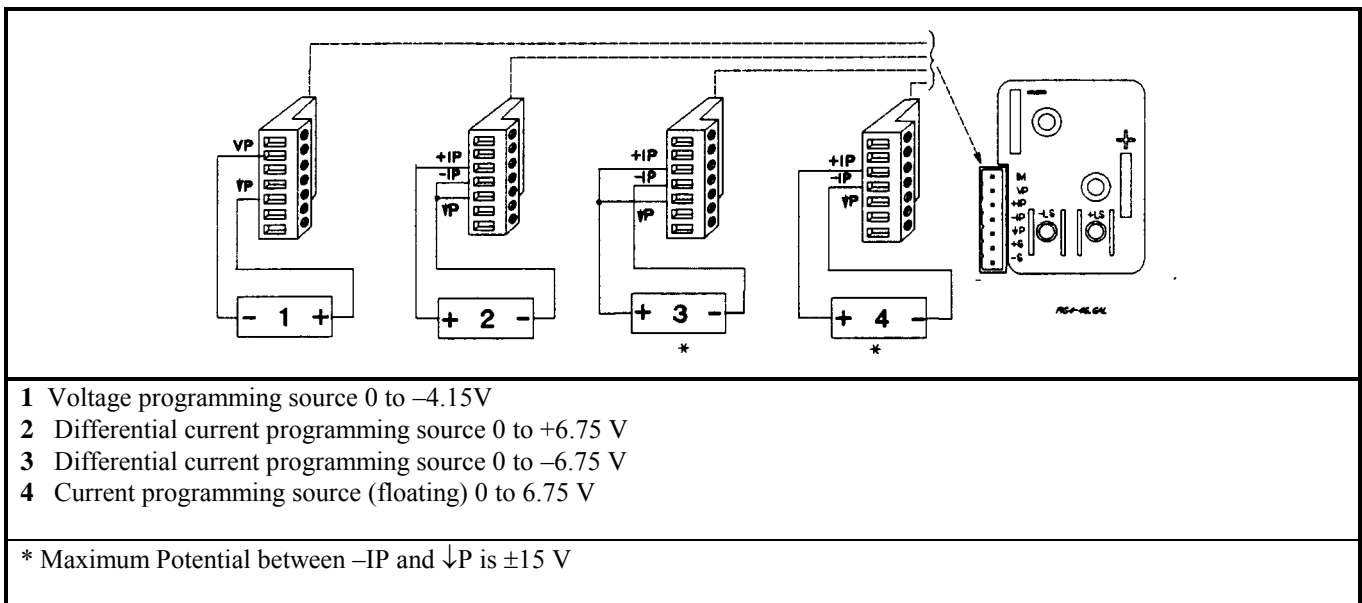

Figure 4-9. Analog Programming Connections

Programming. Note from Figure 4-1 that you have three options for programming the current. You can use a voltage source that is positive, negative, or floating with respect to **Common P**. Do not exceed ± 15 V with respect to **Common P**.



Make certain that the common connection for your voltage programming source is isolated from the load. Failure to do this may cause damage to the power supply.

The effect of the analog programming source is always summed with the values programmed over the GPIB or from the front panel. The voltage source can act alone only if you set the other program sources to zero. Keep the total programmed setting of the unit (the analog input summed with the GPIB or front panel settings) at or under the output ratings specified in Table A-2. Exceeding the output ratings will not damage the unit, but it may not be able to regulate its output at the higher levels. If this happens, the **Unr** annunciator will light to warn you that the output is unregulated.

Controller Connections

Figure 4-10 shows two basic ways of connecting your power supply to a controller. They are "linked" and "stand-alone" configurations.

Stand-Alone Connections

See Figure 4-10A. Each stand-alone power supply has its own GPIB bus address. Stand-alone power supplies may be connected to the bus in series configuration, star configuration, or a combination of the two. You may connect from 1 to 15 stand-alone power supplies to a controller GPIB interface.

Linked Connections

See Figure 4-10B. Up to 16 power supplies may be used at a single GPIB primary bus address by making linked connections. (You cannot use linked connections if you intend to program power supplies with the Compatibility Language - see the Appendix G.)

- The first power supply in a linked connection is a "direct unit" connected to the controller via a GPIB cable. The direct unit is the only unit connected directly to the bus and has a unique primary bus address.
- The remaining power supplies are "linked units" connected to the direct unit via a serial-link cable. Each linked unit has a unique secondary GPIB address and derives its primary address from the direct unit. You may connect from 1 to 15 linked supplies to each direct unit.

Note

The power supply is shipped from the factory with its GPIB address set to 5. The power supply primary and secondary addresses can be changed from the front panel as described in Chapter 6 - "Remote Programming". For power supply GPIB interface capabilities, see Table 1-5 in Chapter 1 of this guide.

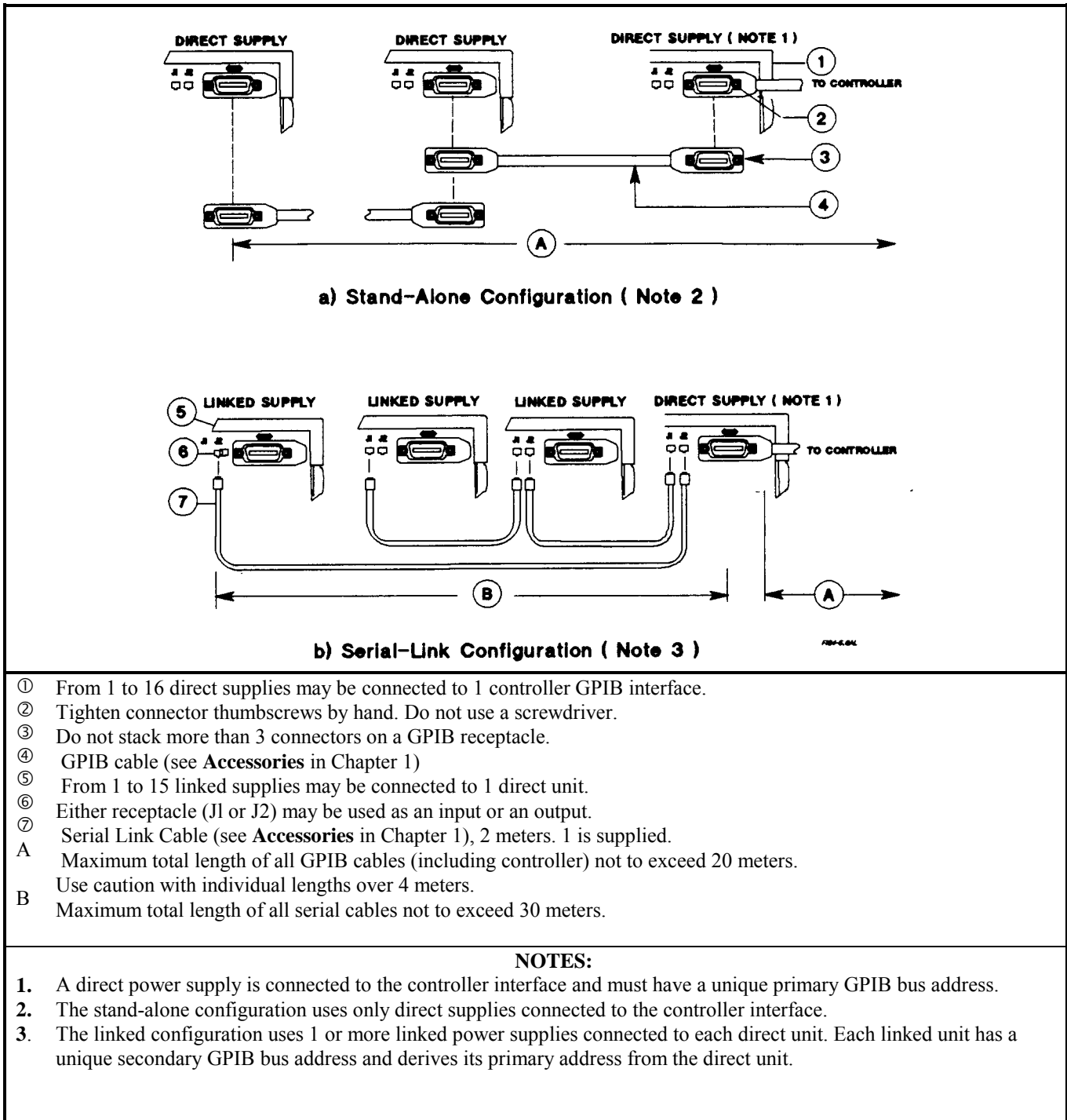

Figure 4-10. Controller Connections

Front Panel Operation

Introduction

This chapter shows you how to operate the front panel. It is assumed that you are familiar with the turn-on checkout procedure in Chapter 3. That chapter describes how to perform basic power supply functions from the control panel. operations that you can perform are:

- Enabling or disabling the power supply output.
- Setting the output voltage and current.
- Monitoring the output voltage and current.
- Setting the overvoltage protection (OVP) trip point.
- Enabling the overcurrent protection (OCP) circuit.
- Saving operating states in nonvolatile memory.
- Recalling operating states from nonvolatile memory.
- Setting the power supply GPIB bus address.
- Displaying error codes created during remote operation.
- Enabling local (front panel) operation.

Note You also can calibrate the power supply from the front panel (see Appendix B).

Getting Acquainted

The front panel is summarized in Figure 5-1 and Table 5-1. Note that the panel is organized as follows:

- ① LCD display (including annunciators)
- ② Output VOLTAGE and CURRENT rotary (RPG) knobs
- ③ SYSTEM keypad
- ④ FUNCTION keypad
- ⑤ ENTRY keypad
- ⑥ Power (LINE) switch

Some keys have two functions. For example, the System **Recall** key can be used either to recall a stored operating state or to **Save** (store) an operating state. The first operation is shown **on** the key and the second (shifted) operation is shown in blue **above** the key. In order to do a shifted operation, first press the solid blue key, which is unlabeled but shown throughout this manual as **Shift**.

For example, for a recall operation, press the recall key **Recall**. For a save operation, press the save key, which is **Shift Recall**. When you do this, the **Shift** annunciator will light to remind you that the **Recall** key is now functioning as the **Save** key. In this chapter, such a shifted operation may be shown simply as **Save**.

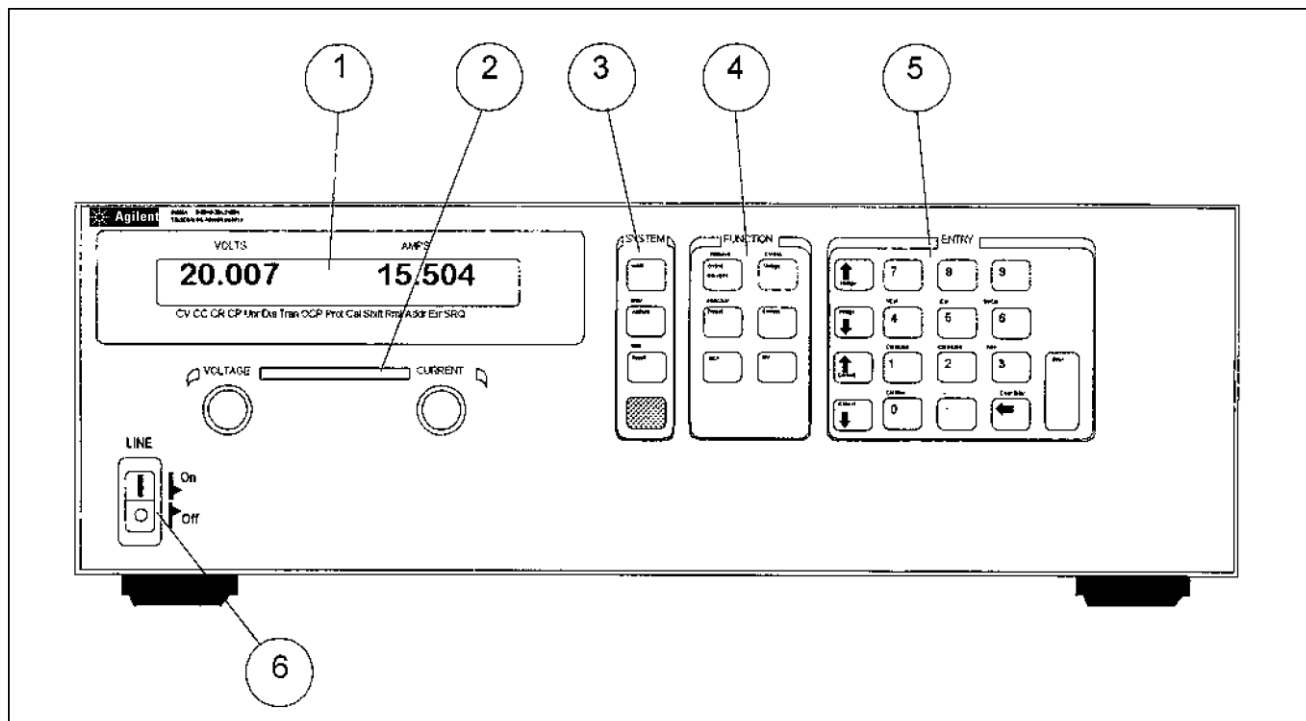



Figure 5-1. Front Panel Controls and Indicators

Table 5-1. Front Panel Controls and Indicators (See Figure 5-1)

Control or Indicator	Function or Indication
① Display	
VOLTS AMPS	Shows present output voltage of the power supply. Shows present output current of the power supply.
Status Annunciators	
CV	The power supply is in constant-voltage mode.
CC	The power supply is in constant-current mode.
Unr	The power supply output is unregulated (output is neither CV or CC).
Dis	The power supply output is disabled.
OCF	The overcurrent protection function is enabled.
Prot	A protection circuit has caused the power supply to shut down. (Press Protect to determine the reason.)
Err	An error has been generated as a result of remote operation. (Press Error to display the error code).
Cal	The power supply is in calibration mode.
Shift	The shift key Shift has been pressed.
Rmt	The power supply is in the remote mode (controlled over the GPIB).
Addr	The power supply is addressed to listen or talk.
SRQ	The power supply is requesting service from the controller.
② Output Rotary Controls	
Voltage	Rotate clockwise to increase output voltage or program setting. Use to rapidly set an approximate output value (see ↑Voltage and ↓Voltage keys).
Current	Rotate clockwise to increase output current or program setting. Use to rapidly set an approximate current value (see ↑Current and ↓Current keys).

Table 5-1. Front Panel Controls and Indicators (continued)

③ SYSTEM Keys	
<p>Local</p> <p>Address</p> <p>Error</p> <p>Recall</p> <p>Save</p> <p></p>	<p>When the power supply is under remote control, press to enable local operation. <i>This control can be defeated by a lock-out command over the GPIB</i></p> <p>Press to display the power supply's GPIB address. You can change the address with the ENTRY keys</p> <p>Use to display error codes generated during remote operation. (Select by pressing Shift Address.)</p> <p>Use to restore a previously saved power supply state. Use ENTRY keys 0 through 4 to specify which location to recall. (Select by pressing Shift Recall.)</p> <p>Note: Location 0 may contain the power supply turn-on state. See "Turn-on operation" in this chapter.</p> <p>Use to save the power supply's present state to nonvolatile memory. (Select by pressing Shift Recall.) Use ENTRY keys to specify the location where you want to store the state. Use locations 0 through 4.</p> <p>This unlabeled blue key is the Shift key. Press to access the shifted (alternate) key functions.</p>
④ Function Keys	
<p>Output On/Off</p> <p>Voltage</p> <p>Current</p> <p>OV</p> <p>Protect</p> <p>Prot Clear</p> <p>OCP</p>	<p>Press to enable or disable the power supply output. This key toggles between the two states. The disabled state programs the output to the *RST voltage and current settings.</p> <p>Press to display the output voltage setting. After pressing Voltage, you may use the ENTRY keys to change the value.</p> <p>Press to display the output current setting. After pressing Current, you may use the ENTRY keys to change the value.</p> <p>Press to display the OV trip voltage setting. After pressing OV, you may use the ENTRY keys to change the value.</p> <p>When the Prot annunciator is on, press Protect to see which protection circuit caused the power supply to shut down. Response can be OC (overcurrent), OT (overtemperature), or OV (overvoltage). If no protection circuit has tripped, the display will show dashes (- - -).</p> <p>Press this key to reset the protection circuit. <i>If the condition that caused the circuit to trip has been removed</i>, the Prot annunciator will go off.</p> <p>Press to enable or disable the power supply OCP trip circuit. This key toggles between the two states, which are indicated by the OCP annunciator.</p>
⑤ ENTRY Keys	
<p>↑Voltage</p> <p>↓Voltage</p> <p>↑Current</p> <p>↓Current</p> <p>0 - 9 .</p> <p>-</p> <p>←</p>	<p>Press to increment the output voltage in the CV mode, or to increase the voltage setting after you have pressed the Voltage key.³</p> <p>Press to decrement the output voltage in the CV mode, or to decrease the voltage setting after you have pressed the Voltage key.³</p> <p>Press to increment the output current in the CC mode, or to increase the current setting after you have pressed the Current key.³</p> <p>Press to decrement the output current in the CC mode, or to decrease the current setting after you have pressed the Current key.³</p> <p>Press to select numerical values.</p> <p>Press to enter a minus sign.</p> <p>Press to delete the last keypad entry. Use this key to remove one or more incorrect digits before they are entered.</p>
<p>³ These four entry keys operate in two modes. Press and release for a single minimal change as determined by the programming resolution (see Table A-2). Press and hold for an increasingly rapid output change.</p>	
<p>Clear Entry</p> <p>Enter</p>	<p>Press to delete an entire keypad entry and return to the meter mode. Use this key to exit from a value before it is entered.</p> <p>Press to enter a value or to accept an existing value and return the display to the meter mode. The remaining shifted keys are for calibration (see Appendix B - "Calibration").</p>

Programming The Output

Important These instructions show how to program a single power supply. There are special considerations when you have two or more supplies connected in series or in autoperallel. See "Chapter 4 - User Connections and Considerations".

The power supply accepts values directly in volts and amperes. Values will be rounded off to the nearest multiple of the output resolution (see "Programming Resolution" in Table A-2). If you attempt to enter a value not in a valid range, the unit will either switch to the other range or the entry will be ignored and **OUT OF RANGE** appears on the display.

Figure 1-1 shows the general response of the E4356A power supply. Unless directed otherwise, always keep the output voltage and current within the boundaries of its operating line for the specified mode of operation (CV or CC).

Establishing Initial Conditions

Set the power supply to its *RST state by pressing **Recall** **0** **Enter**. This state was stored in location 0 at the factory. If it has since been changed, you can restore it as directed under "Turn-on Conditions", later in this chapter. *RST results in the following operating conditions:

- Zero voltage output.
- Minimal current output.
- Output disabled (**Dis** annunciator on).
- Overcurrent protection off (**OCP** annunciator off).
- Protection circuits cleared (**Prot** annunciator off).
- Overvoltage protection set to maximum.

Programming Voltage

To program the output for 45 volts, proceed as follows:

- Press **Voltage**. The display will change from meter mode to indicate **VOLTS**.
- Press **4** **5** **Enter**. If you discover a mistake before pressing **Enter**, erase the incorrect value with the **←** key.
- The display will return to the meter mode and indicate 0.000 volts.
- Press **Output On/Off** to enable the output (**Dis** annunciator turns off). The **VOLTS** display will indicate 45.00 volts.

Note The power supply must be programmed for a minimal current in order to increase the output voltage beyond zero. Normally, there is sufficient idle current to do this. If the power supply does not respond or the **CC** annunciator turns on, go to "Programming Current" and set the current to a small value.

- Now raise the voltage by pressing **↑Voltage**. Note that the voltage increases by a specific increment (depending on the voltage programming resolution) each time you press the key and increases rapidly as you hold down the key. To lower the voltage, press **↓Voltage**.
- Try raising and lowering the voltage by rotating the **Voltage** control clockwise and then counterclockwise. Note how the output responds as compared to using the **Entry** keys.
- Try to program a voltage greater than the V_{MAX} for your unit (see Table A-2). Note that the display shows **OUT OF RANGE**.

Programming Overvoltage Protection

Overvoltage protection guards the load against voltages that reach a specified value above the programmed output voltage.

Setting the OVP Level. Assuming that you have programmed the power supply for 45 volts, you can set the OVP level to 48 volts as follows:

- Press **OV**. The display will change from meter mode to indicate 0V, followed by the present OVP value.
- Press **4 8 Enter**.
- The display will return to the meter mode and indicate the output (45.00 volts).
- Press **OV** again. The display will now indicate **0V 48.00**.
- Press **Enter** to return to the meter mode.

Checking OVP Operation. Assuming the above operating conditions (voltage programmed to 45 V and OVP programmed to 48 V), trip the OVP circuit as follows:

- Gradually increase the output voltage by pressing **↑Voltage** until the OVP circuit trips. This will cause the output voltage to drop to zero and the **Prot** annunciator to go on.
- There now is no power supply output due to an overvoltage condition.
- To verify this, press **Protect** and observe that the display indicates **0V**. This shows that the protection circuit tripped due to an overvoltage condition.

Clearing The OVP Condition. With the OVP tripped, return to the meter mode and try to clear the condition by pressing **Prot Clear**. Nothing will appear to happen because the OV trip voltage is still below the programmed output voltage. Thus, as soon as the circuit is cleared, it trips again. You can clear the OV condition by:

- Lowering the output voltage below 48 (the OV setting), or
- By raising the OV trip voltage above the output voltage setting.

Try either of these methods. Now when you press **Prot Clear**, the **Prot** annunciator will turn off and the output voltage will return to normal.

Programming Current

You may program the power supply current without a load, but must have a load in order to draw output current. These tests assume you have the load connected in accordance with the information in Chapter 4. If you do not have a load on the power supply, you may connect a short across the output terminals as described in Chapter 3.

The example will program a low current. (You may later increase the output current to the levels you will expect to use.) To program the output current to 1.3 amperes, proceed as follows:

- Disable the output by pressing **Output On/Off**. The **Dis** annunciator will turn on.
- Program the voltage by pressing **Voltage 5 Enter**.
- Press **Current**. The display will change from meter mode to indicate **AMPS**.
- Press **1 . 3 Enter**. If you discover a mistake before pressing **Enter** erase the incorrect value with the backspace key **←**.
- The display will return to the meter mode and indicate up to 0 . 000.
- Press **Output On/Off** to enable the output. **Dis** will turn off and the display will indicate **VOLTS 5 . 000 AMPS 1 . 300**.
- Now increase the current by pressing **↑Current**. Note that the current increases by a specific increment (depending on the current programming resolution) each time you press the key and increases rapidly as you hold down the key. To decrease the current, press **↓Current**.
- Try increasing and decreasing the current by rotating the **Current** knob clockwise and counterclockwise. Note how the output responds as compared to using the **Entry** keys.
- Disable the output by pressing **Output On/Off**. The **Dis** annunciator will turn on. Now try to program a current greater than the I_{MAX} for your unit. Note that the display shows **OUT OF RANGE**.

Programming Overcurrent Protection

When enabled, overcurrent protection removes the power supply output whenever it goes into CC operation. This prevents the unit from indefinitely uniting the full programmed current to the load.

Setting The OCP Protection. To activate overcurrent protection, press **OCP**. The **OCP** annunciator will light and power supply will continue to operate normally until it is forced into CC operation. If that occurs, the OCP circuit will trip and the power supply will remove its output.

Checking OCP Operation. The easiest way to check this operation at any specified current is to increase the load current beyond the programmed current value and, if necessary, decrease the programmed voltage. This will force the power supply into CC mode (see Figure 1-1). When OCP trips, the **Prot** annunciator will light and the output will drop to zero.

There is now no power supply output due to an overcurrent condition. To verify this, press **Protect** and observe that the display indicates **OC**.

Clearing The OCP Condition. With the OCP tripped, return to the meter mode and try to clear the condition by pressing **Prot Clear**. Nothing will appear to happen because the reason for the condition has not been removed. Thus, as soon as the circuit is cleared, it trips again. You can clear the OC condition by:

- Increasing the load resistance to lower the output current below the programmed current value, or
- By raising the programmed current to a value above that required by the load.

Clear the fault by either of the above methods. Then clear the OCP circuit by pressing **Prot Clear**. The **Prot** annunciator will go off and the output will be restored to normal.

If desired, you can also restore the output by disabling the OCP function (press **OCP** to turn off the **OCP** annunciator). This restores the output but does not clear any condition that may have caused OCP to trip.

Note

Under certain conditions, the OCP circuit may fail to clear because load demand occurs before the power supply has time to build up the required output current capacity. In such cases, disable the output (press **Output On/Off** before clearing the OCP circuit). After OCP is cleared, then enable the power supply output.

CV Mode vs. CC Mode

Once you program a voltage (V_S) and a current (I_S) in Figure 1-1, the power supply will try to maintain itself in either CV or CC mode, depending on the impedance of the load (R_L). If the load demands less current than I_S , operation will be in CV mode with the voltage maintained at V_S . The output current will be at some value below I_S as determined by $V_S \div R_L$. If the current increases beyond I_S (see R_{L2}), the unit will switch to CC mode by varying its output voltage to maintain a constant current value of I_S . As more current is demanded, the voltage decreases to maintain the increased current level. If the load current increases to the maximum output of the power supply, the output voltage will be maintained at a near-zero level.

Unregulated Operation

If the power supply goes into a mode of operation that is neither CV nor CC, the **Unr** annunciator will light. An unregulated condition limits the output current to a value that is safe for the power supply. Some unregulated states occur so briefly that they do not turn on the **Unr** annunciator, but they may set the **UNR** status bit during remote operation. One condition that can cause a noticeable unregulated state is low ac line voltage.

Saving and Recalling Operating States

You can save programming time by storing up to 5 operating states in nonvolatile memory. The front panel programming parameters that are saved are:

- Output voltage, Output current, *OVP voltage,
- OCP state (on or off), Output state (enabled or disabled).

Note More power supply parameters are saved in remote operation. See Chapter 7.

As an example, set up the following state:

Voltage = 45 V Current = 5 A OVP voltage = 48 V.

OCP = on (**OCP** annunciator on) Output = off (**Dis** annunciator on).

Save the above state to location 1 by pressing **Save** **1** **Enter**. Now set up the following state:

Voltage = 50 V Current = 2.5 A OVP voltage = 55 V.

OCP = off (**OCP** annunciator off) Output = on (**Dis** annunciator off).

Save the above state to location 2 by pressing **Save** **2** **Enter**.

Restore the first state by pressing **Recall** **1** **Enter** and verify the parameters. Restore the second state by pressing **Recall** **2** **Enter**. Note how the power supply is automatically programmed each time.

Turn-On Conditions

Whenever you apply power to a new power supply it automatically turns on in a safe reset state with the following parameters:

Output On/Off off **Voltage** 0 **Current** minimum*

OV maximum **OCP** off

*Minimum is the *RST value specified in Table A-2.

It is recommended that you leave the turn-on conditions as programmed. However, you may change them. To do this:

1. Set up the power supply to the state you want when it is turned on.
 2. Store that state to location 0.
 3. Turn off the power supply.
 4. Hold in the **8** key and turn the power supply back on. The display indicates **RCL 0 PWR-ON** to verify that the power supply has configured its turn-on state to that stored in location 0.
 5. From now on the unit will always turn on to the state defined in location 0.
- To return the power supply to the original factory reset state, hold down the **9** key when you turn on the unit. The display indicates **RST POWER-ON** to verify that the power supply has configured its turn-on state to the original reset state. From now on it will continue to turn on in that state.

Setting The GPIB Address

Types of Power supply GPIB Addresses

Figure 4-8 in Chapter 4 shows the ways the power supply can be connected to the GPIB bus. You can set up the GPIB address in one of three ways:

1. As a stand-alone unit (the only unit at the address). It has a primary address in the range of 0 to 30. For example: **5** or **7**.
2. As the direct unit in a serial link. It is the only unit connected directly to the GPIB bus. The primary address is unique and can be from 0 to 30. It is entered as an integer followed by a decimal separator. The secondary address always is 0, which may be added after the primary address. If the secondary address is omitted, it is assumed to be 0. For example: **5.0** or **7**.
3. As a linked unit in serial link. It gets its primary address from the direct unit. It has a unique secondary address that can be from 1 to 15. It is entered as an integer preceded by a decimal separator. For example: **.1** or **.12**

When you enter a secondary address, leading zeros between the decimal separator and the first digit are ignored. For example, .1, .01, and .001 are accepted as secondary address 1 and displayed as **0.01**. Zeros following a digit are not ignored. Thus, .10 and .010 are both accepted as secondary address 10 and displayed as **0.10**.

Changing the Power supply GPIB Address

Use the **Address** key and numerical keypad for entering addresses. The power supply is shipped with a 5 stand-alone address as the default. The general procedure for setting an address is:

Action	Display Shows
Press Address	Current address
Press new address keys	New address replaces numbers on the display
Press Enter	Display returns to meter mode

If you try to enter a forbidden number, **ADDR ERROR** is displayed.

The following examples show how to set addresses:

To set stand-alone primary address **6**, press **Address** **6** **Enter**.

To set direct unit primary address **6**, press **Address** **6** **.** **Enter**.

To set linked secondary address **1**, press **Address** **.** **1** **Enter**.

To set linked secondary address **12**, press **Address** **.** **1** **2** **Enter**.

Note	<p>The power supply display will reset (recall the state in location 0) whenever you change between the following types of GPIB addresses:</p> <ul style="list-style-type: none"> • a stand-alone primary address and a direct primary address. • a direct primary address and a secondary address.
-------------	---

Remote Programming

Prerequisites for Remote Programming

This organization of this guide assumes that you know or can learn the following information:

1. How to program in your controller language (Keysight BASIC, QUICKBASIC, C, etc.).
2. The basics of the GPIB (IEEE 488).
3. How to program I/O statements for an IEEE 488 bus instrument. From a programming aspect, the power supply is simply a bus instrument.
4. How to format ASCII statements within your I/O programming statements. SCPI commands are nothing more than ASCII data strings incorporated within those I/O statements.
5. The basic operating principles of the power supply as explained in “Chapter 5 – Front Panel Operation” of the Operating Guide.
6. How to set the GPIB address of the power supply. This cannot be done remotely, but only from the unit’s front panel (see Chapter 5 – “Setting the GPIB Address”).

External Documents

SCPI References

The following documents will assist you with programming in SCPI:

- *Standard Commands for Programmable Instruments Volume 1, Syntax and Style*
- *Standard Commands for Programmable Instruments Volume 2, Command References*
- *Standard Commands for Programmable Instruments Volume 3, Data Interchange Format*
- *Standard Commands for Programmable Instruments Volume 4, Instrument Classes*

To obtain a copy of the above documents, contact: Fred Bode, Executive Director, SCPI Consortium, 8380 Hercules Drive, Suite P3, Ls Mesa, CA 91942, USA

GPIB References

The most important GPIB documents are your controller programming manuals - Keysight BASIC, GPIB Command Library for MS DOS, etc. Refer to these for all non-SCPI commands (for example: Local Lockout).

The following are two formal documents concerning the GPIB interface:

- *ANSI/IEEE Std. 488.1-1987 IEEE Standard Digital Interface for Programmable Instrumentation.*
Defines the technical details of the GPIB interface. While much of the information is beyond the need of most programmers, it can serve to clarify terms used in this guide and in related documents.
- *ANSI/IEEE Std. 488.2-1987 IEEE Standard Codes, Formats, Protocols, and Common Commands.*
Recommended as a reference only if you intend to do fairly sophisticated programming. Helpful for finding precise definitions of certain types of SCPI message formats, data types, or common commands.

The above two documents are available from the IEEE (Institute of Electrical and Electronics Engineers), 345 East 47th Street, New York, NY 10017, USA. The WEB address is www.ieee.org.

GPIB Capabilities of the Power supply

All power supply functions except for setting the GPIB address are programmable over the IEEE 488 bus (also known as the General Purpose Interface Bus or "GPIB"). The IEEE 488.1 capabilities of the power supply are listed in the Supplemental Characteristics in Table A-2. The power supply operates from a GPIB address that is set from the front panel (see **System Considerations** at the end of this chapter).

Introduction To SCPI

Important Learn the basics of power supply operation (see Chapter 5 - "Front Panel Operation") before using SCPI.

SCPI (Standard Commands for Programmable Instruments) is a programming language for controlling instrument functions over the GPIB (IEEE 488) instrument bus. SCPI is intended to function with standard GPIB hardware and conforms to the IEEE Standard Digital Interface for Programmable Instrumentation. SCPI is layered on top of the hardware portion of IEEE 488.2. The same SCPI commands and parameters control the same functions in different classes of instruments. For example, you would use the same DISPLAY command to control the power supply display state and the display state of a SCPI-compatible multimeter.

Note HPSL and TMSL (Test and Measurement System Language) were earlier versions of SCPI. If you have programmed in either, then you probably can go directly to "Chapter 3 - Language Dictionary".

Conventions

The following conventions are used throughout this chapter:

Angle brackets	< >	Items within angle brackets are parameter abbreviations. For example, <NR1> indicates a specific form of numerical data.
Vertical bar		Vertical bars separate one of two or more alternative parameters. For example, 0 OFF indicates that you may enter either "0" or "OFF" for the required parameter.
Square Brackets	[]	Items within square brackets are optional. The representation [SOURCE]:CURRENT means that SOURCE may be omitted.
Braces	{ }	Braces indicate parameters that may be repeated zero or more times. It is used especially for showing arrays. The notation <A>{<,B>} shows that "A" is a required parameter, while "B" may be omitted or may be entered one or more times.
Boldface font		Boldface font is used to emphasize syntax in command definitions. TRIGger:DELay <NRf> shows a command syntax.
Computer font		Computer font is used to show program text within normal text. TRIGger:DELay .5 represents program text.

Types of SCPI Commands

SCPI has two types of commands, common and subsystem.

Common Commands. Common commands generally are not related to specific operation but to controlling overall power supply functions, such as reset, status, and synchronization. All common commands consist of a three-letter mnemonic preceded by an asterisk: ***RST *IDN? *SRE 8**

Subsystem Commands. Subsystem commands (see Figure 6-1) perform specific power supply functions. They are organized into an inverted tree structure with the "root" at the top. Some are single commands while others are grouped under other subsystems.

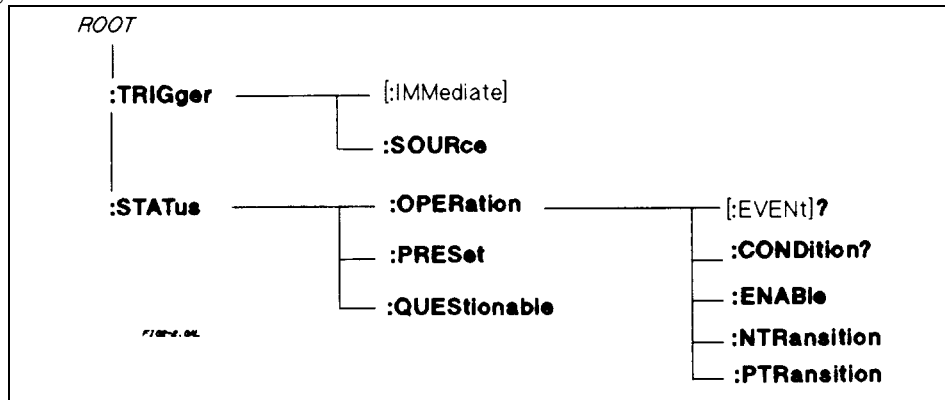

Figure 6-1. Partial Command Tree

Traversing the Command Tree

Figure 6-1 shows a portion of the subsystem command tree (you can see the complete tree in Figure 7-2). Note the location of the ROOT node at the top of the tree. The SCPI interface is at this location when:

- The power supply is powered on.
- A device clear (DCL) is sent to the power supply.
- The interface encounters a message terminator.
- The interface encounters a root specifier.

Active Header Path

In order to properly traverse the command tree, you must understand the concept of the active header path. When the power supply is turned on (or under any of the other conditions listed above), the active path is at the root. That means the interface is ready to accept any command at the root level, such as **TRIGger** or **STATus** in Figure 6-1. Note that you do not have to precede either command with a colon; there is an implied colon in front of every root-level command.

If you enter **STATUS**, the active header path moves one colon to the right. The interface is now ready to accept **:OPERATION**, **:PRESET**, or **:QUESTIONABLE** as the next header. Note that you must include the colon, because it is required between headers.

If you next enter **:OPERATION**, the active path again moves one colon to the right. The interface is now ready to accept **:EVENT?**, **:CONDITON?**, **ENABLE**, **NTRANSITION**, or **PTRANSITION** as the next header.

If you now enter **:ENABLE**, you have reached the end of the command string. The active header path remains at **:ENABLE**. If you wished, you could have entered **:ENABLE 18;PTRANSITION 18** and it would be accepted. The entire message would be **STATUS:OPERATION:ENABLE 18;PTRANSITION 18**. The message terminator after **PTRANSITION 18** returns the path to the root.

The Effect of Optional Headers

If a command includes optional headers, the interface assumes they are there. For example, if you enter **STATUS:OPERATION?**, the interface recognizes it as **STATUS: OPERATION: EVENT?**. This returns the active path to the root (**:STATUS**). But if you enter **STATUS: OPERATION: EVENT?**, then the active path remains at **:EVENT**. This allows you to send **STATUS: OPERATION: EVENT?; CONDITION?** in one message. If you tried to send **STATUS:OPERATION?;CONDITION?** the command path would send **STATUS:OPERATION:EVENT?** and then return to **:STATUS** instead of to **:CONDITION**.

The optional header **SOURCE** precedes the current, digital, and voltage subsystems. This effectively makes **:CURRENT**, **:DIGITAL**, and **:VOLTAGE** root-level commands.

Moving Among Subsystems

In order to combine commands from different subsystems, you need to be able to restore the active path to the root. You do this with the root specifier (:). For example, you could clear the output protection and check the status of the Operation Condition register as follows :

```
OUTPUT:PROTECTION:CLEAR
STATUS:OPERATION:CONDITION?
```

By using the root specifier, you could do the same thing in one message:

```
OUTPUT:PROTECTION:CLEAR;:STATUS:OPERATION:CONDITION?
```

Note The SCPI parser traverses the command tree as described in Appendix A of the IEEE 488.2 standard. The "Enhanced Tree Walking Implementation" given in that appendix is *not* implemented in the power supply.

The following message shows how to combine commands from different subsystems as well as within the same subsystem:

```
VOLTAGE:LEVEL 7;PROTECTION 8;:CURRENT:LEVEL I50;PROTECTION ON
```

Note the use of the optional header **LEVEL** to maintain the correct path within the voltage and current subsystems and the use of the root specifier to move between subsystems.

Including Common Commands

You can combine common commands with system commands in the same message. Treat the common command as a message unit by separating it with the message unit separator. Common commands *do not affect the active header path*; you may insert them anywhere in the message.

```
VOLT:TRIG 7.5;INIT;*TRG
OUTP OFF;*RCL 2;OUTP ON
```

SCPI Queries

Observe the following precautions with queries:

- Remember to set up the proper number of variables for the returned data.
- Set the program to read back all the results of a query before sending another command to the power supply. Otherwise, a *Query Interrupted* error will occur and the unreturned data will be lost.

Value Coupling

Value coupling results when a command directed to send one parameter also changes the value of a second parameter. There is no direct coupling among any power supply SCPI commands. However, be aware that until they are programmed, uninitialized trigger levels will assume their corresponding immediate levels. For example, if a power supply is powered up and **VOLT:LEV** is programmed to **6**, then **VOLT:LEV:TRIG** will also be **6** until you program it to another value. Once you program **VOLT:LEV:TRIG** to another value, it will remain at that value regardless of how you subsequently reprogram **VOLT:LEVEL**.

Types of SCPI Messages

There are two types of SCPI messages, program and response.

- A *program message* consists of one or more properly formatted SCPI commands sent from the controller to the power supply. The message, which may be sent at any time, requests the power supply to perform some action.
- A *response message* consists of data in a specific SCPI format sent from the power supply to the controller. The power supply sends the message only when commanded by a special program message called a "query."

Structure of a SCPI Message

SCPI messages consist of one or more message units ending in a message terminator. The terminator is not part of the syntax, but implicit in the way your programming language indicates the end of a line (such as a newline or end-of-line character).

The following command message (see Figure 6-2) is briefly described here, with more details in subsequent paragraphs.

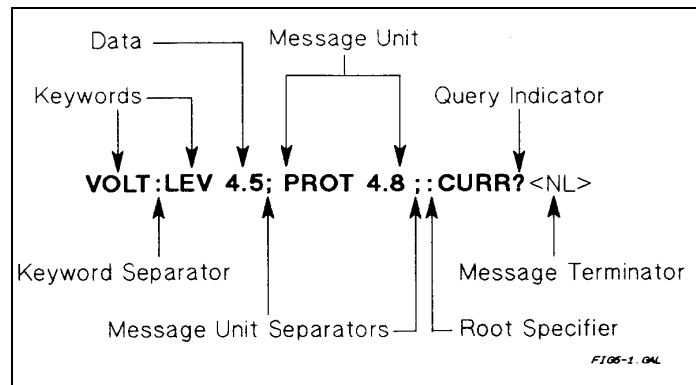

The basic parts of the message in Figure 6-1 are:

Message Component	Example
Headers	VOLT LEV PROT CURR
Header Separator	The colon in VOLT:LEV
Data	4.5 4.8
Data Separator	The space in VOLT 4.5 and PROT 4.8
Message Units	VOLT:LEV 4.5 PROT 4.8 CURR?
Message Unit Separator	The semicolons in VOLT: LEV 4.5; and PROT 4.8;
Root Specifier	The colon in PROT 4.8; : CURR?
Query Indicator	The question mark in CURR?
Message Terminator	The <NL> (newline) indicator. Terminators are not part of the SCPI syntax.

The Message Unit. The simplest SCPI command is a single message unit consisting of a command header (or keyword) followed by a message terminator.

ABOR
VOLT?

The message unit may include a parameter after the header. The parameter usually is numeric, but it can be a string:

VOLT 20
VOLT MAX

Headers. Headers (which are sometimes known as "keywords") are instructions recognized by the power supply interface. Headers may be either in the long form or the short form.

Long Form	The header is completely spelled out, such as VOLTAGE STATUS DELAY .
Short Form	The header has only the first three or four letters, such as VOLT STAT DEL .

Short form headers are constructed according to the following rules:

- If the header consists of *four or fewer* letters, use all the letters. (**DFI DATA**)
- If the header consists of *five or more* letters and the fourth letter is not a vowel (a,e,i,o,u), use the first four letters. (**VOLTage STATus**)
- If the header consists of *five or more* letters and the fourth letter is a vowel (a,e,i,o,u), use the first three letters. (**DELAy CLEAr**)

You must follow the above rules when entering headers. Creating an arbitrary form, such as **QUEST** for **QUESTIONABLE**, will result in an error. The SCPI interface is not sensitive to case. It will recognize any case mixture, such as **VOLTAGE**, **Voltage**, **Volt**, **volt**.

Note Shortform headers result in faster program execution.

Header Convention. In this manual, headers are emphasized with **boldface** type. The proper short form is shown in upper-case letters, such as **DELAy**.

Header Separator. If a command has more than one header, you must separate them with a colon. (**VOLT:PROT OUTPut:PROTection:CLEAr**)

Optional Headers. The use of some headers is optional. Optional headers are shown in brackets, such as **OUTPut[:STATe] ON**. However, if you combine two or more message units into a compound message, you may need to enter the optional header. This is explained under "Traversing the Command Tree."

Query Indicator. Following a header with a question mark turns it into a query (**VOLT? VOLT:PROT?**). If a query contains a parameter, place the query indicator at the end of the last header (**VOLT:PROT? MAX**).

Message Unit Separator. When two or more message units are combined into a compound message, separate the units with a semicolon (**STATus:OPERation?:QUEStionable?**).

Important You can combine message units only at the current path of the command tree (see "Traversing the Command Tree").

Root Specifier. When it precedes the first header of a message unit, the colon becomes a "root specifier". This indicates that the command path is at the root or top node of the command tree. Note the difference between root specifiers and header separators in the following examples:

OUTP:PROT:DEL .1	All colons are header separators
:OUTP:PROT:DEL .1	The first colon is a root specifier
OUTP:PROT:DEL .1;VOLT 12.5	The third colon is a root specifier

Message Terminator. A terminator informs SCPI that it has reached the end of a message. Three permitted message terminators are:

- Newline (<NL>), which is ASCII decimal 10 or hex 0A.
- End or identify (<END>)
- Both of the above (<NL><END>).

In the examples of this manual, there is an assumed message terminator at the end of each message. If the terminator needs to be shown, it is indicated as <NL> regardless of the actual terminator character.

SCPI Data Formats

All data programmed to or returned from the power supply is ASCII. The data may be *numerical* or *character string*.

Numerical Data

Table 6-1 and Table 6-2 summarize the numerical formats.

Table 6-1. Numerical Data Formats

Symbol	Data Form
Talking Formats	
<NR1>	Digits with an implied decimal point assumed at the right of the least-significant digit. Examples: 273 0273
<NR2>	Digits with an explicit decimal point. Example: 273. .0273
<NR3>	Digits with an explicit decimal point and an exponent. Example: 2.73E+2 273.0E-2
Listening Formats	
<NRf>	Extended format that includes <NR1>, <NR2> and <NR3>. Examples: 273 273. 2.73E2
<NRf+>	Expanded decimal format that includes <NRf>, MIN and MAX . Examples: 273 273. 2.73E2 MAX. MIN and MAX are the minimum and maximum limit values that are implicit in the range specification for the parameter.

Table 6-2. Suffixes and Multipliers

Class	Suffix	Unit	Unit with Multiplier
Current	A	Ampere	MA (milliampere)
Amplitude	V	Volt	MV (millivolt)
Time	S	second	MS (millisecond)
Common Multipliers			
	1E3	K	kilo
	1E-3	M	milli
	1E-6	U	micro

Boolean Data

Either form {**1|0**} or {**ON|OFF**} may be sent with commands. Queries always return 1 or 0.

OUTPut OFF

CURRent:PROTection 1

Character Data

For query statements, character strings may be returned in either of the forms shown in Table 6-3, depending on the length of the returned string.

Table 6-3. Character Data Formats

<CRD>	<u>Character Response Data</u> . Permits the return of character strings.
<AARD>	<u>Arbitrary ASCII Response Data</u> . Permits the return of undelimited 7-bit ASCII. This data type has an implied message terminator.
Note:	The IEEE 488.2 format for a string parameter requires that the string be enclosed within either single (' ') or double (" ") quotes. Be certain that your program statements comply with this requirement.

SCPI Command Completion

SCPI commands sent to the power supply are processed either sequentially or in parallel. Sequential commands finish execution before a subsequent command begins. A parallel command can begin execution while a preexisting command is still executing (overlapping commands). Commands that affect trigger actions are among the parallel commands.

The ***WAI**, ***OPC**, and ***OPC?** common commands provide different ways of indicating when all transmitted commands, including any parallel ones, have completed their operations. The syntax and parameters for these commands are described in Chapter 7 - "Language Dictionary". Some practical considerations for using these commands are as follows:

- *WAI** This prevents the power supply from processing subsequent commands until all pending operations are completed. If something prevents completion of an existing operation, ***WAI** can place the power supply and the controller in a "hang- up" condition.
- *OPC?** This places a 1 in the Output Queue when all pending operations have completed. Because it requires your program to read the returned value from the queue before executing the next program statement, ***OPC?** could prevent subsequent commands from being executed.
- *OPC** This sets the OPC status bit when all pending operations have completed. Since your program can read this status bit on an interrupt basis, ***OPC** allows subsequent commands to be executed.

The trigger subsystem must be in the Idle state in order for the status OPC bit to be true. Therefore, as far as triggers are concerned, OPC is false whenever the trigger subsystem is in the Initiated state. However, OPC is also false if there are any commands still pending.

Note For a detailed discussion of ***WAI**, ***OPC** and ***OPC?**, see "Device/Controller Synchronization Techniques" in ANSI/IEEE Std 488.2.

Programming Examples

The examples given here are generic, without regard to the programming language or type of GPIB interface. Because SCPI commands are sent as ASCII output strings within the programming language statements, the SCPI syntax is independent of both programming language and interface.

Note The examples are followed by sample program code written for three popular types of BASIC-controlled GPIB interfaces.

Important The power supply responds simultaneously to both digital and analog programming inputs. If it is receiving an input over the GPIB and a corresponding input from the front panel (and/or from the analog programming port), the power supply output will be the algebraic sum of the inputs.

Programming Voltage and Current

The following statements program both voltage and current and return the actual output from the sense terminals:

OUTP OFF	<i>Disable the output.</i>
VOLT 45;CURR 25	<i>Program the voltage and current.</i>
VOLT?;CURR?	<i>Read back the programmed levels.</i>
OUTP ON	<i>Enable the output.</i>
MEAS:VOLT?;MEAS:CURR?	<i>Read back the outputs from the sense terminals.</i>

Programming Protection Circuits

This example programs the voltage and current, programs an overvoltage protection value, and turns on the overcurrent protection. It then reads back all the programmed values.

VOLT:LEV 45;PROT 47.5	<i>Program the voltage and overvoltage protection.</i>
CURR:LEV 25;PROT:STAT ON	<i>Program the current and overcurrent protection.</i>
VOLT:LEV?;PROT?;CURR:LEV?;PROT:STAT?	<i>Read back the programmed values.</i>

Note the required use of the optional **LEVel** header in the above example (see "The Effect of Optional Headers", given previously).

Changing Outputs by Trigger

If you do not program pending triggered levels, they default to the programmed (immediate) output levels. The following statements shows some basic trigger commands.

OUTP OFF	<i>Disable the output.</i>
VOLT:LEV:IMM 22;TRIG 25	<i>Program the (immediate) voltage level to 22V and the pending triggered level to 25 V.</i>
CURR:LEV:IMM 15;TRIG 25	<i>Program the (immediate) current level to 15 A and the pending triggered level to 25 A.</i>
VOLT:LEV:IMM?;TRIG?;CURR:LEV:IMM?;TRIG?	<i>Check all the programmed values.</i>
OUTP ON	<i>Enable the output.</i>
MEAS:VOLT?;CURR?	<i>Read back the immediate levels from the sense terminals.</i>
INIT;TRIG	<i>Arm the trigger circuit and send a single trigger.</i>
INIT;*TRG	<i>Same as above, except using a common command.</i>
MEAS:VOLT?;CURR?	<i>Read back the triggered levels from the sense terminals.</i>

If you need to send two or more triggers, program the trigger circuit for continuous arming.

OUTP OFF	<i>Disable the output.</i>
VOLT:LEV:IMM 50;TRIG 25	<i>Program the (immediate) voltage level to 50 V and the pending triggered level to 25 V.</i>
INTIT:CONT ON	<i>Program the trigger circuit for continuous arming.</i>
OUTP ON	<i>Enable the output to 50 V.</i>
TRIG	<i>Trigger the output voltage to 25 V.</i>
VOLT:TRIG 50;TRIG	<i>Set the pending trigger level to 50 V and trigger the output voltage back to 50 V.</i>
INTIT:CONT OFF	<i>Remove the continuous trigger arming.</i>

Saving and Recalling States

You can remotely save and recall operating states. See ***SAV** and ***RCL** in "Chapter 7 - Language Dictionary" for the parameters that are saved and recalled.

Note When you turn the power supply on, it automatically retrieves the state stored in location 0. When a power supply is delivered, this location contains the factory defaults (see ***RST** in Chapter 7).

OUTP OFF;VOLT:LEV 65;PROT 68	<i>Program a desired operating state.</i>
CURR:LEV 33;PROT:STAT ON	
*SAV 2	<i>Save this state to location 2.</i>
*RCL 2	<i>(Later) recall this same state.</i>

Writing to the Display

You can include messages to the front panel LCD in your programs. The description of **DISP:TEXT** in "Chapter 7 - Language Dictionary" shows the number and types of permitted display characters. In order to write to the display, you must first change it to text mode as shown in the following example:

DIS:MODE TEXT	<i>Switch display to text mode.</i>
RECALLED 2	<i>Write "Recalled 2" to the display.</i>
DIS:MODE NORM	<i>Return display to its normal mode.</i>

Programming Status

You can use status programming to make your program react to events within the power supply. Chapter 8 explains the functions and bit configurations of all status registers. Refer to Figure 8-1 in that chapter while examining the examples given here.

Detecting Events via SRQ

Usually you will want the power supply to generate interrupts (assert SRQ) upon particular events. For this you must selectively enable the appropriate status register bits. The following examples allow the power supply to assert SRQ under selected conditions.

1. **STAT:OPER:ENAB 1280;PTR 1280;*SRE 128** *Assert SRQ when the unit switches between CV and CC modes.*
2. **STAT:OPER:ENAB 1;PTR 1;NTR 1;*SRE 128** *Assert SRQ when the unit enters or leaves calibration mode.*
3. **STAT:QUES 3;PTR 3;*SRE 128** *Assert SRQ when the unit goes into overvoltage or overcurrent condition.*
4. **STAT:OPER:ENAB 1280;PTR 1280;** *Assert SRQ under any event occurring in 1. or 3., above.*
STAT:QUES 3;PTR 3;*SRE 136

Reading Specific Registers

You can exercise program control without interrupts by reading specific registers.

STAT:OPER:1280;EVEN?	<i>Enable only the CV and CC events and read their status.</i>
STAT:OPER:ENAB 1313;PTR 1313;EVEN?	<i>Enable all conditions of the Operation Status register and read any events.</i>
STAT:OPER:ENAB?;EVENT?;:STAT:QUES:ENAB?;EVEN?;:*ESE?;*ESR?	<i>Read which events are active and which events are enabled in the Operation, Questionable, and Standard Event status registers.</i>

Note The last query string can be handled without difficulty. However, should you request too many queries, the system may return a "Query DEADLOCKED" error (-430). In that case, break the long string into smaller parts.

Programming the Digital I/O Port

Digital control ports 1 and 2 are TTL outputs that can be programmed either high or low. Control port 3 can be programmed to be either a TTL input or a TTL output. Send a decimal parameter that translates into the desired straight binary code for these ports. (See **DIG:DATA[:VAL]** in "Chapter 3 - Language Dictionary" for the port bit configurations.)

DIG:DATA 3 *Set ports 1 and 2 high and make 3 another output port.*
DIG:DATA 7 *Set ports 1 and 2 high and make 3 an input port.*
DIG:DATA? *Read back the present port configuration.*

System Considerations

The remainder of this chapter addresses some system issues concerning programming. These are power supply addressing and the use of the following types of GPIB system interfaces:

1. HP Vectra PC controller with Keysight 82335A GPIB Interface Command Library.
2. IBM PC controller with National Instruments GPIB-PCII Interface/Handler.
3. Keysight controller with Keysight BASIC Language System.

Setting the GPIB Address

The power supply address cannot be set remotely; it must be set from the front panel. Once the address is set, you can assign it inside programs. Figure 4-10 shows the ways the power supply can be connected to the GPIB bus. You can set up the GPIB address in one of three ways:

1. As a stand-alone unit (the only unit at the address). It has a primary address in the range of 0 to 30. For example:
5 or **7**
2. As the direct unit in a serial link. It is the only unit connected directly to the GPIB bus. The primary address is unique and can be from 0 to 30. It is entered as an integer followed by a decimal separator. The secondary address always is 0, which may be added after the primary address. If the secondary address is omitted, it is assumed to be 0. For example:
5.0 or **7.**
3. As a linked unit in serial link. It gets its primary address from the direct unit. It has a unique secondary address that can be from 1 to 15. It is entered as an integer preceded by a decimal separator. For example:
.1 or **.12**

When you enter a secondary address, leading zeros between the decimal separator and the first digit are ignored. For example, .1, .01, and .001 are accepted as secondary address 1 and displayed as 0.01. Zeros following a digit are not ignored. Thus, .10 and .010 are both accepted as secondary address 10 and displayed as 0.10.

Changing the Power supply GPIB Address

Use the **Address** key and numerical keypad for entering addresses. The power supply is shipped with a 5 stand-alone address as the default. The general procedure for setting an address is:

Action	Display Shows
Press Address	Current address
Press new address keys	New address replaces numbers on the display

Press **Enter** Display returns to meter mode

If you try to enter a forbidden number, **ADDR ERROR** is displayed.

The following examples show how to set addresses:

To set stand-alone primary address **6**, press **Address** **6** **Enter**

To set direct unit primary address **6**, press **Address** **6** **.** **Enter**

To set linked secondary address **1**, press **Address** **.** **1** **Enter**

To set linked secondary address **12**, press **Address** **.** **1** **2** **Enter**

Note The power supply display will reset (recall the state in location 0) whenever you change between the following types of GPIB addresses:

- A stand-alone primary address and a direct primary address.
 - A direct primary address and a secondary address.
-

Assigning the GPIB Address In Programs

The following examples assume that the GPIB select code is 7, the the power supply is 6, and that the power supply address will be assigned to the variable *@PS*.

```
1000 !Stand-alone address. The power supply will respond if it is set to 6
1010 PS=706 !Statement for Keysight 82335A Interface
1010 ASSIGN @PS TO 706 ! Statement for Keysight BASIC Interface
1020 !Direct address. The power supply will respond if it is set to 6. or 6.0
1030 PS=70600 ! Statement for Keysight 82335A Interface
1030 ASSIGN @PS TO 70600 ! Statement for Keysight BASIC Interface
1040 !Linked address 1. The power supply will respond if it is set to address .1 and is serially connected to a
unit at direct address 6.0
1050 PS=706.01 !Keysight 82335A Interface
1090 ASSIGN @PS TO 706.01 !Keysight BASIC Interface
```

For systems using the National Instruments DOS driver, the address is specified in the software configuration program (IBCONFIG.EXE) and assigned a symbolic name. The address then is referenced only by this name within the application program (see the National Instruments GP-IB documentation).

DOS Drivers

Types of Drivers

The Keysight 82335A and National Instruments GPIB are two popular DOS drivers. Each is briefly described here. See the software documentation supplied with the driver for more details.

Keysight 82335A Driver. For GW-BASIC programming, the GPIB library is implemented as a series of subroutine calls. To access these subroutines, your application program must include the header file SETUP.BAS, which is part of the DOS driver software.

SETUP.BAS starts at program line 5 and can run up to line 999. Your application programs must begin at line 1000. SETUP.BAS has built-in error checking routines that provide a method to check for GPIB errors during program execution. You can use the error-trapping code in these routines or write your own code using the same variables as used by SETUP.BAS.

National Instruments GP-IB Driver. Your program must include the National Instruments header file DECL.BAS. This contains the initialization code for the interface. Prior to running any applications programs, you must set up the interface with the configuration program (IBCONF.EXE).

Your application program will not include the power supply symbolic name and GPIB address. These must be specified during configuration (when you run IBCONF.EXE). Note that the primary address range is from 0 to 30 but any secondary address must be specified in the address range of 96 to 126. The power supply expects a message termination on EOI or line feed, so set *EOI w/last byte of Write*. It is also recommended that you set *Disable Auto Serial Polling*.

All function calls return the status word *IBSTA%*, which contains a bit (ERR) that is set if the call results in an error. When ERR is set, an appropriate code is placed in variable *IBERR%*. Be sure to check *IBSTA%* after every function call. If it is not equal to zero, branch to an error handler that reads *IBERR%* to extract the specific error.

Error Handling

If there is no error-handling code in your program, undetected errors can cause unpredictable results. This includes "hanging up" the controller and forcing you to reset the system. Both of the above DOS drivers have routines for detecting program execution errors.

Important Use error detection after every call to a subroutine.

Keysight BASIC Controllers

The Keysight BASIC Programming Language provides access to GPIB functions at the operating system level. This makes it unnecessary to have the header files required in front of DOS applications programs. Also, you do not have to be concerned about controller "hangups" as long as your program includes a timeout statement. Because the power supply can be programmed to generate SRQ on errors, your program can use an SRQ service routine for decoding detected errors. The detectable errors are listed in Table D-1 in Appendix D.

Sample Program Code

The following programs are intended only to show how some of the same power supply functions can be programmed to each of the three previously mentioned GPIB interfaces. The first two are for the DOS interfaces and the third for the Keysight BASIC interface.

Programming Some Power supply Functions

SAMPLE FOR POWER SUPPLY AT STAND-ALONE ADDRESS 6. SEQUENCE SETS UP CV MODE OPERATION, FORCES UNIT TO SWITCH TO CC MODE, AND DETECTS AND REPORTS MODE CHANGE.

HP Vectra PC Controller Using Keysight 82335A Interface

```

5      ' < ----- Merge SETUP.BAS here ----- >
1000   MAX.ELEMENTS=2 : ACTUAL.ELEMENTS=0 :MAX.LENGTH=80 :ACT.LENGTH=0
1005   DIM OUTPUTS(2) :CDD$=SPACE$(40)
1010   ISC=7 :PS=706
1015   '
1020   'Set up the Power supply Interface for DOS driver
1025   CALL IORESET (ISC)                                'Reset the interface
1030   IF PCIB.ERR < > NOERR THEN ERROR PCIB.BASERR
1035   TIMEOUT=3
1040   CALL IOTIMEOUT (ISC, TIMEOUT)                     'Set timeout to 3 seconds
1045   IF PCIB.ERR < > NOERR THEN ERROR PCIB.BASERR
1050   CALL IOCLEAR (ISC)                                'Clear the interface
1055   IF PCIB.ERR <> NOERR THEN ERROR PCIB.BASERR
1060   CALL IOREMOTE (ISC)                               'Set Power supply to remote mode
1065   IF PCIB.ERR <> NOERR THEN ERROR PCIB.BASERR
1070   '
1075   'Program power supply to CV mode with following voltage and current
1080   CODES$ = "VOLTAGE 78;CURRENT 25"                   :GOSUB 2000
1085   '
1090   'Query power supply outputs & print to screen
1095   CODES$ = "MEASURE:VOLTAGE?;CURRENT?"              :GOSUB 2000 :GOSUB 3000
1100   VOUT = OUTPUTS(1)
1105   IOUT = OUTPUTS(2)
1110   PRINT "The output levels are "VOUT" Volts and "IOUT" Amps"
1115   '
1120   'Program triggered current level to value insufficient to maintain
1125   'unit within its CV operating characteristic
1130   CODES$ = "CURR:TRIG 1"                             :GOSUB 2000
1135   '
1140   'Set operation status mask to detect mode change from CV to CC
1145   CODES$ = "STAT:OPER:ENAB 1024;PTR 1024"          :GOSUB 2000
1150   '
1155   'Enable Status Byte OPER summary bit
1160   CODES$ = "**SRE 128"                               :GOSUB 2000
1165   '
1170   'Arm trigger circuit and send trigger to power supply
1175   CODES$ = "INITIATE;TRIGGER"                       :GOSUB 2000
1180   '
1185   'Wait for unit to respond to trigger
1190   FOR I= 1 to 100 :NEXT I
1195   '
1200   'Poll for interrupt caused by change to CC mode and print to screen
1205   CALL IOSPOLL (PS,RESPONSE)
1210   IF (RESPONSE AND 128)<>128 THEN GOTO 1240         'No OPER event to report
1215   CODES$ = "STATUS:OPER:EVEN?"                     :GOSUB 2000 'Query status oper register

```

Programming Some Power supply Functions (continued)

```

1220 CALL IOENTER (PS,OEVENT)                                'Read back event bit
1225 IF PCIB.ERR < > NOERR THEN ERROR PCIB.BASERR
1230 IF (OEVENT AND 1024) = 1024 THEN PRINT "Unit switched to CC mode."
1240 'Clear the status circuit
1245 CODES$ = "**CLS" :GOSUB 2000
1260 FOR I = 1 TO 100 :NEXT I      'Wait for unit to clear
1265 '
1260 'Disable output and save present state in location 2
1265 CODES$ = "OUTPUT OFF;*SAV 2"                                :GOSUB 2000
1270 END
1275 '
2000 'Send command to power supply
2005 LENGTH = LEN(CODES$)
2010 CALL IOOUTPUTS (PS,CODES$,LENGTH)                        'Send command to interface
2015 IF PCIB.ERR < > NOERR THEN ERROR PCIB.BASERR            ISETUP.BAS error trap
2020 RETURN
2025 '
3000 'Get data from power supply
3005 CALL IOENTERA (PS,OUTPUTS(1),MAX.ELEMENTS,ACTUAL.ELEMENTS)
3010 IF PCIB.ERR < > NOERR THEN ERROR PCIB.BASERR
3015 RETURN
*****
                        IBM Controller Using National Interface
*****
990 '----- Merge DECL.BAS here -----
1000 'Power supply Variable = PS% ; Stand-Alone Address = 706
1005 CODES$=SPACE$(50):MODE$=SPACE$(5):OEVENT$=SPACE$(20)
1010 D$=SPACE$(60):OUTPUT$=SPACE$(40):BDNAME$="PS%"
1015 DIM OUTPUT(2)
1020 '
1025 'Set up power supply interface for DOS driver
1030 CALL IBFIND(BDNAME$,PS%)
1035 IF PS%<0 THEN PRINT "IBFIND Failed."
1040 CALL IBCLR(PS%)
1045 '
1050 'Program power supply to CV mode with following voltage and current
1055 CODES$ = "VOLTAGE 78;CURRENT 25"                                :GOSUB 2000
1060 '
1065 'Query power supply outputs and print to screen
1070 CODES$ = "MEASURE:VOLTAGE?;CURRENT?"                            :GOSUB 2000 :GOSUB 3000
1075 VOUT = OUTPUT(1)
1080 IOUT = OUTPUT(2)
1085 PRINT "The programmed levels are "VOUT" Volts and "IOUT" Amps"
1090 '
1095 'Program triggered current level to value insufficient to maintain
1100 'unit within its CV operating characteristic
1105 CODES$ = "CURR:TRIG 1"                                          :GOSUB 200
1110 '
1115 'Set operation status mask to detect mode change from CV to CC
1120 CODES$ = "STAT:OPER:ENAB 1024;PTR 1024"                        :GOSUB 2000
1125 '

```

Programming Some Power supply Functions (continued)

```

1130 'Enable Status Byte OPER summary bit
1135 CODES$ = "**SRE 128" :GOSUB 2000
1140 '
1146 'Arm trigger circuit and send trigger to power supply
1150 CODES$ = "INITIATE;TRIGGER" :GOSUB 2000
1160 'Wait for unit to respond to trigger
1165 FOR I= 1 to 100 :NEXT I
1170 '
1175 'Poll for interrupt caused by change to CC mode and print to screen
1180 SPOL%=0
1186 CALL IBRSP(PS%,SPOL%)
1190 IF (SPOL% AND 128) = 128 THEN POLL = 1 'Set interrupt flag on OPER bit
1195 IF POLL < > 1 THEN GOTO 1230 'No interrupt to service
1200 "CODES$ = "STAT:OPER:EVEN?" :GOSUB 2000 'Query status oper register
1205 CALL IBRD(PS%,OEVENT$) 'Read back event bit
1210 IF IBSTA% <0 THEN GOTO 2100
1215 OEVENT=VAL(OEVENT$)
1220 IF (OEVENT AND 1024) = 1024 THEN PRINT "Unit switched to CC mode."
1225 '
1230 'Clear status circuit
1235 CODES$="**CLS" :GOSUB 2000
1240 FOR I=1 TO 50 :NEXT I 'Wait for unit to clear
1245 '
1250 'Disable output and save present state to location 2
1255 CODES$ = "OUTPUT OFF;*SAV 2" :GOSUB 2000
1260 END
1265 '
2000 'Send command to power supply
2005 CALL IBWRT(PS%,CODES$)
2010 IF IBSTAT% < 0 THEN GOTO 2100 'Error detected
2015 RETURN
1250 'Disable output and save present state to location 2
1255 CODES$ = "OUTPUT OFF;*SAV 2" :GOSUB 2000
1260 END
1265 '
2000 'Send command to power supply
2005 CALL IBWRT(PS%,CODES$)
2010 IF IBSTAT% < 0 THEN GOTO 2100 'Error detected
2015 RETURN
2020 '
2100 'Error detection routine
2105 PRINT "GPIB error. IBSTAT%. = &H";HEX$(IBSTAT%)
2110 PRINT " IBERR% = ";IBERR% in line ";ERL
2115 STOP
2120 '
3000 'Get data from power supply
3005 CALL IBRD(PS%,OUTPUT$)
3010 IF IBSTA% < 0 THEN GOTO 2100
3015 I=1 'Parse data string
3020 X=1
3025 C=INSTR(I,OUTPUT$,";")

```

Programming Some Power supply Functions (continued)

```

3030 WHILE C < > 0
3035     D$ = MID$(OUTPUT$, I, C - I)
3040     OUTPUT(X) = VAL(D$)                                'Get values
3045     I = C + 1
3050     C = INSTR(I, OUTPUT$, ";")
3055     X = X + 1
3060 WEND
3065 D$ = RIGHT$(OUTPUT$, LEN(OUTPUT$) - (I - 1))
3070 OUTPUT(X) = VAL(D$)
3076 OUTPUT$ = SPACE$(40)                                'Clear string
3080 RETURN
*****
        Controller Using Keysight BASIC
*****
1000 !Power supply at stand-alone address = 706
1005 OPTION BASE 1
1010 DIM Codes$(80), Response$(80), Mode$(32)
1015 !
1020 !Program power supply to CV mode with following voltage and current
1026 OUTPUT 706; "VOLTAGE 78; CURRENT 25"
1030 !
1035 !Query power supply outputs and print to screen
1040 OUTPUT 706; "MEASURE: VOLTAGE?; CURRENT?"            !Query output levels
1045 ENTER 706; Vout, Iout
1050 PRINT "The output levels are "; Vout; " Volts and "; Iout; " Amps"
1055 !
1060 !Program current triggered level to a value insufficient to maintain
1065 !unit within its CV operating characteristic
1070 OUTPUT 706; "CURR: TRIG 1"
1075 !
1080 !Set operation status mask to detect mode change from CV to CC
1085 OUTPUT 706; "STAT: OPER: ENAB 1280; PTR 1280"
1090 !
1095 !Enable Status Byte OPER summary bit
1100 OUTPUT 706; "*SRE 128"
1105 !
1110 !Arm trigger circuit and send trigger to power supply
1115 OUTPUT 706; "INITIATE; TRIGGER"
1130 !Poll for interrupt caused by change to CC mode and print to screen
1135 Response = SPOLL(706)
1140 IF NOT BIT(Response, 7) THEN GOTO 1130                !No OPER event to report
1145 OUTPUT 706; "STAT: OPER: EVEN?"                      !Query status operation register
1160 ENTER 706; Oevent                                    !Read back event bit
1156 IF BIT(Oevent, 10) THEN PRINT "Unit switched to CC mode."
1160 !
1165 !Clear status
1170 OUTPUT 706; "*CLS"
1176 !
1180 !Disable output and save present state in location 2
1185 OUTPUT 706; "OUTPUT OFF; *SAV 2"
1190 END

```

SCPI Confirmed Commands¹

This power supply conforms to Version 1990.0.

ABOR	OUTP:PROT:DEL	TRIG[:STAR]:DEL
CAL[:STAT]	OUTP:PROT:DEL?	TRIG[:STAR]:DEL?
[SOUR]:CURR[:LEV][:IMM][:AMPL]	STAT:OPER[:EVEN]?	TRIG[:STAR]:SOUR
[SOUR]:CURR[:LEV][:IMMI][:AMPL]	STAT:OPER:COND?	TRIG[:STAR]:SOUR?
?		
(SOUR):CURR[:LEV]:TRIG[:AMPL]	STAT:OPER:ENAB	[SOUR]:VOLT[:LEV][:IMMI][:AMPL]
(SOUR):CURR[:LEV]:TRIG[:AMPL]?	STAT:OPER:ENAB?	[SOUR]:VOLT[:LEV][:IMM][:AMPL]?
[SOUR]:CURR:PROT:STAT	STAT:OPER:NTR	[SOUR]:VOLT[:LEV]:TRIG[:AMPL]
[SOUR]:CURR:PROT:STAT?	STAT:OPER:NTR?	[SOUR]:VOLT[:LEV]:TRIG[:AMPL]?
DISP[:WIND][:STAT]	STAT:OPER:PTR	[SOUR]:VOLT:PROT[:LEV]
DISP[:WIND][:STAT]?	STAT:OPER:PTR?	[SOUR]:VOLT:PROT[:LEV]?
DISP[:WIND]:TEXT[:DATA]	STAT:PRES	*CLS *RCL
DISP[:WIND]:TEXT[:DATA]?	STAT:QUES[:EVEN]?	*ESE *RST
INIT[:IMM]	STAT:QUES:COND?	*ESE? *SAV
INIT:CONT	STAT:QUES:ENAB	*ESR? *SRE
INIT:CONT?	STAT:QUES:ENAB?	*IDN? *SRE?
MEAS:CURR[:DC]?	SYST:ERR?	*OPC *STB?
MEAS:VOLT[:DC]?	SYST:LANG	*OPC? *TRG
OUTP[:STAT]	SYST:LANG?	*PSC *TST?
OUTP[:STAT]?	SYST:VERS?	*PSC? *WAI
OUTP:PROT:CLE	TRIG[:STAR][:IMM]	

¹See Appendix B - Calibration, for CAL commands.

NON-SCPI Commands

CAL:CURR[:DATA]	CAL:VOLT:LEV	OUTP:REL:POL
CAL:CURR:LEV	CAL:VOLT:PROT	OUTP:REL:POL?
CAL:CURR:MON	[SOUR]:DIG:DATA[:VAL]	OUTP:REL[:STAT]
CAL:PASS	[SOUR]:DIG:DATA[:VAL]?	OUTP:REL[:STAT]?
CAL:SAV	DISP[:WIND]:MODE	[SOUR]:VOLT:PROT[:AMPL]
CAL:VOLT[:DATA]	DISP[:WIND]:MODE?	[SOUR]:VOLT:PROT[:AMPL]?

Language Dictionary

Introduction

This section gives the syntax and parameters for all the IEEE 488.2 SCPI commands and the Common commands used by the power supply. It is assumed that you are familiar with the material in Chapter 6 - "Remote Programming". That chapter explains the terms, symbols, and syntactical structures used here and gives an introduction to programming. You should also be familiar with Chapter 5 - "Front Panel Operation" in order to understand how the power supply functions.

The programming examples are simple applications of SCPI commands. Since SCPI syntax remains the same for all programming languages, the examples are generic.

Syntax definitions use the long form, but only short form headers (or "keywords") appear in the examples. If you have any concern that the meaning of a header in your program listing will not be obvious at some later time, then use the long form to help make your program self-documenting.

Parameters

Most commands require a parameter and all queries will return a parameter. The range for a parameter may vary according to the model of power supply. Parameters for all current models are listed in Table 7-1 at the end of this chapter.

Related Commands

Where appropriate, related commands or queries are included. These are listed either because they are directly related by function or because reading about them will clarify or enhance your understanding of the original command or query.

Order of Presentation

The dictionary is organized as follows:

- IEEE 488.2 common commands, in alphabetical order.
- Subsystem commands.

Common Commands

Common commands begin with an * and consist of three letters (command) or three letters and a ? (query). *Common* commands are defined by the IEEE 488.2 standard to perform some common interface functions. The power supply responds to the 13 required common commands that control status reporting, synchronization, and internal operations. The power supply also responds to five optional common commands controlling triggers, power-on conditions, and stored operating parameters.

Subsystem Commands

Subsystem commands are specific to power supply functions. They can be a single command or a group of commands. The groups are comprised of commands that extend one or more levels below the root. The description of subsystem commands follows the listing of the common commands.

Description Of Common Commands

Figure 7-1 shows the common commands and queries. These commands are listed alphabetically in the dictionary. If a command has a corresponding query that simply returns the data or status specified by the command, then both command and query are included under the explanation for the command. If a query does not have a corresponding command or is functionally different from the command, then the query is listed separately. The description of each common command or query specifies any status registers affected. In order to make use of this information, you must refer to "Chapter 8 - Status Reporting", which explains how to read specific register bits and use the information that they return.

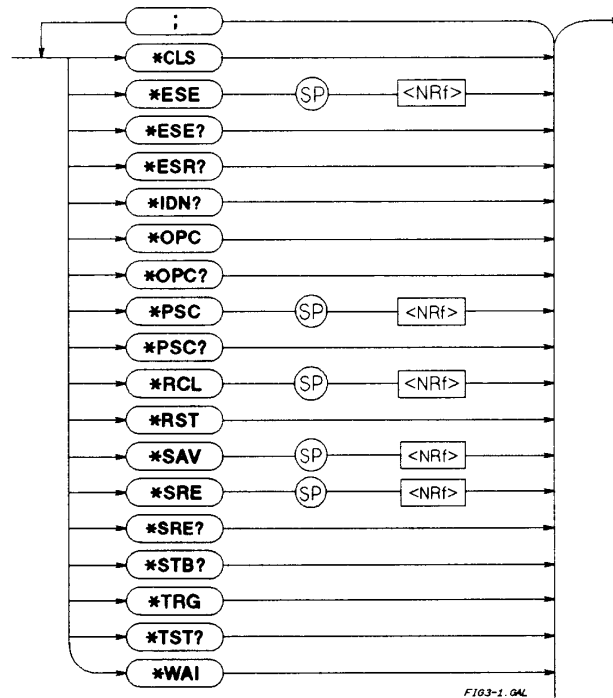

Figure 7-1. Common Commands Syntax Diagram

*CLS

Meaning and Type

Clear Status Device Status

Description

This command causes the following actions (see "Chapter 8 - Status Reporting" for descriptions of all registers):

- Clears the following registers:
 - Standard Event Status.
 - Operation Status Event.
 - Questionable Status Event.
 - Status Byte.
- Clears the Error Queue.
- If *CLS immediately follows a program message terminator (<NL>), then the output queue and the MAV bit are also cleared.

Command Syntax	*CLS
Parameters	(None)
Query Syntax	(None)

*ESE

Meaning and Type

Event Status Enable Device Status

Description

This command programs the Standard Event Status Enable register bits. The programming determines which events of the Standard Event Status Event register (see ***ESR?**) are allowed to set the ESB (Event Summary Bit) of the Status Byte register. A "1" in the bit position enables the corresponding event. All of the enabled events of the Standard Event Status Event register are logically ORed to cause the Event Summary Bit (ESB) of the Status Byte register to be set. See "Chapter 4 - Status Reporting" for descriptions of all three registers.

Bit Configuration of Standard Event Status Enable Register

Bit Position	7	6	5	4	3	2	1	0
Bit Name	PON	0	CME	EXE	DDE	QYE	0	OPC
Bit Weight	128	64	32	16	8	4	2	1

CME = Command error; DDE = Device-dependent error; EXE = Execution error; OPC = Operation complete; PON Power-on; QYE = Query error.

Command Syntax	*ESE <Nrf>
Parameters	<i>0 to 255</i>
Power On Value	(See *PSC)
Suffix	(None)
Example	*ESE 129
Query Syntax	*ESE?
Returned Parameters	<NR1> (Register value)
Related Commands	*ESR? *PSC *STB?

CAUTION

If **PSC** is programmed to 0, then the ***ESE** command causes a write cycle to nonvolatile memory. The nonvolatile memory has a finite maximum number of write cycles (see Table A-2, Supplementary Characteristics). Programs that repeatedly cause write cycles to nonvolatile memory can eventually exceed the maximum number of write cycles and may cause the memory to fail.

*ESR?

Meaning and Type

Event Status Register Device Status

Description

This query reads the Standard Event Status Event register. Reading the register clears it. The bit configuration of this register is the same as the Standard Event Status Enable register (***ESE**). See "Chapter 8 - Status Reporting" for a detailed explanation of this register.

Query Syntax	*ESR?
Parameters	(None)
Returned Parameters	<NR1> (Register binary value)
Related Commands	*CLS *ESE *ESE? *OPC

*IDN?

Meaning and Type

Identification Query System Interface

Description

This query requests the power supply to identify itself. It returns a string composed of four fields separated by commas.

Query Syntax	*IDN?	
Returned Parameters	<AARD>	
	Field	Information
	<i>Keysight Technologies</i>	Manufacturer
	.xxxxA	4-digit model number followed by a letter suffix
	nnnnA-nnnnn	10-character serial number or 0
	<R>.xx.xx	Revision levels of firmware
Example	Keysight Technologies,6681,0,A.00.01	
Related Commands	(None)	

*OPC

Meaning and Type

Operation Complete Device Status

Description

This command causes the interface to set the OPC bit (bit 0) of the Standard Event Status register when the power supply has completed all pending operations. (See *ESE for the bit configuration of the Standard Event Status register.) *Pending operations* are complete when:

- All commands sent before *OPC have been executed. This includes overlapped commands. Most commands are sequential and are completed before the next command is executed. Overlapped commands are executed in parallel with other commands. Commands that affect output voltage, current or state, relays, and trigger actions are overlapped with subsequent commands sent to the power supply. The *OPC command provides notification that all overlapped commands have been completed.
- Any change in the output level caused by previous commands has been completed (completion of settling time, relay bounce, etc.)
- All triggered actions are completed

*OPC does not prevent processing of subsequent commands but Bit 0 will not be set until all pending operations are completed.

Command Syntax	*OPC
Parameters	(None)
Related Commands	*OPC? *WAI

*OPC?

Meaning and Type

Operation Complete Device Status

Description

This query causes the interface to place an ASCII "1" in the Output Queue when all pending operations are completed. *Pending operations* are as defined for the *OPC command. Unlike *OPC, *OPC? prevents processing of all subsequent commands. *OPC? is intended to be used at the end of a command line so that the application program can then monitor the bus for data until it receives the "1" from the power module Output Queue.

CAUTION

Do not follow *OPC? with *TRG or GPIB bus triggers. Such triggers sent after *OPC? will be prevented from executing and will prevent the power supply from accepting further commands. If this occurs, the only programmable way to restore operation is by sending the power supply a GPIB DCL (Device Clear) command.

Query Syntax	*OPC?	
Returned Parameters	<NR1>	ASCII 1 is placed in the Output Queue when the power supply has completed operations.
Related Commands	*OPC *TRIG *WAI	

*OPT?

Meaning and Type

Option Identification Query

Description

This query requests the power supply to identify any options that are installed. Options are identified by number A. 0 indicates no options are installed.

Query Syntax	*OPT?
Returned Parameters	<AARD>

*PSC

Meaning and Type

Power-on Status Clear Device Initialization

Description

This command controls the automatic clearing at power turn-on of:

- The Service Request Enable register.
- The Standard Event Status Enable register.

If the command parameter = 1, then the above registers are cleared at power turn-on. If the command parameter = 0, then the above registers are not cleared at power turn-on but are programmed to their last state prior to power turn on. This is the most common application for *PSC and enables the power module to generate an SRQ (Service Request) at power on.

Command Syntax	*PSC <bool>
Parameters	0 1 OFF ON
Example	*PSC 0 *PSC 1
Query Syntax	*PSC?
Returned Parameters	<NR1> 0 1
Related Commands	*ESE *SRE

CAUTION

*PSC causes a write cycle to nonvolatile memory. If *PSC is programmed to 0, then the *ESE and *SRE commands also cause a write cycle to nonvolatile memory. The nonvolatile memory has a finite number of write cycles (see Table A-2, Supplementary Characteristics). Programs that repeatedly write to nonvolatile memory can eventually exceed the maximum number of write cycles and may cause the memory to fail.

*RCL

Meaning and Type

Recall Device State

WARNING

Recalling a previously stored state may place hazardous voltage at the power supply output.

Description

This command restores the power supply to a state that was previously stored in memory with a *SAV command to the specified location. The following states are recalled:

CURR[:LEV][:IMM]	OUTP[:STAT]	OUTP:REL:POL
CURR:PROT:STAT	OUTP:PROT:DEL	VOLT[:LEV][:IMM]
DIG:DATA[:VAL]	OUTP:REL[:STAT]	VOLT:PROT[:LEV]

Sending *RCL also does the following:

- Forces an **ABORT** command before resetting any parameters (this cancels any uncompleted trigger actions).
- Disables the calibration function by setting **CAL:STATe** to **OFF**.
- Sets display functions as follows:
 - **DISP[:WIND][:STATe]** to **ON**.
 - **DISP[:WIND]:MODE** to **NORMAL**.
 - **DISP[:WIND]:TEXT** to **''**.
- Sets **INIT:CONT** to **OFF**.
- Sets **TRIG:SOUR** to **BUS**.

At power turn-on, the power supply normally is returned to the factory defined turn-on state (see *RST). However, it also may turn on to the state stored in location 0 (see *Turn-On Condition* under "Chapter 5 - Front Panel Operation" of the power supply Operating Guide).

Command Syntax	*RCL <NRf>
Parameters	0 1 2 3
Example	*RCL 3
Query Syntax	(None)
Related Commands	*PSC *RST *SAV

*RST

Meaning and Type

Reset Device State

Description

This command resets the power supply to a factory-defined state as defined below. *RST also forces an **ABORT** command.

<u>Command</u>	<u>State</u>
CAL:STAT <i>OFF</i>	OUTP[:STAT] <i>OFF</i>
CURR[:LEV][:IMM] *	OUTP:PROT:DEL *
CURR[:LEV]:TRIG *	OUTP:REL[:STAT] <i>OFF</i>
CURR:PROT:STAT <i>OFF</i>	OUTP:REL:POL <i>NORM</i>
DIG:DATA <i>0</i>	TRIG:SOUR <i>BUS</i>
DISP[:WIND]:STAT <i>ON</i>	VOLT[:LEV][:IMM] *
DISP[:WIND]:MODE <i>NORM</i>	VOLT[:LEV]:TRIG *
DISP[:WIND]:TEXT	VOLT:PROT[:LEV] *
INIT:CONT <i>OFF</i>	

* Model-dependent. See Table 7-1.

Command Syntax	*RST
Parameters	(None)
Query Syntax	(None)
Related Commands	*PSC *SAV

*SAV

Meaning and Type

SAVE Device State

Description

This command stores the present state of the power supply to the specified location in memory. Up to four states can be stored. Under certain conditions (see "Turn-On Conditions" in "Chapter 5 - Front Panel Operation"), location *0* may hold the device state that is automatically recalled at power turn-on.

The following power supply parameters are stored by *SAV:

CURR[:LEV][:IMM]	OUTP[:STAT]	OUTP:REL:POL
CURR:PROT:STAT	OUTP:PROT:DEL	VOLT[:LEV][:IMM]
DIG:DATA[:VAL]	OUTP:REL[:STAT]	VOLT:PROT[:LEV]

Command Syntax	*SAV <NRf>
Parameters	0 1 2 3
Example	SAV 3
Query Syntax	(None)
Related Commands	*RCL *RST

CAUTION

The power supply uses nonvolatile memory for recording register states. Programs that repeatedly use *SAV for recalling states cause frequent write cycles to the memory and can eventually exceed the maximum number of write cycles for the memory.

*SRE

Meaning and Type

Service Request Enable Device Interface

Description

This command sets the condition of the Service Request Enable Register. This register determines which bits from the Status Byte Register (see *STB for its bit configuration) are allowed to set the Master Status Summary (MSS) bit and the Request for Service (RQS) summary bit. A 1 in any Service Request Enable Register bit position enables the corresponding Status Byte Register bit and all such enabled bits then are logically ORed to cause Bit 6 of the Status Byte Register to be set. See "Chapter 8 - Status Reporting" for more details concerning this process.

When the controller conducts a serial poll in response to SRQ, the RQS bit is cleared, but the MSS bit is not. When *SRE is cleared (by programming it with 0), the power supply cannot generate an SRQ to the controller.

Command Syntax	*SRE <NRf>
Parameters	0-to 255
Default Value	(See *PSC)
Example	*SRE 20
Query Syntax	*SRE?
Returned Parameters	<NR1> (Register binary value)
Related Commands	*ESE *ESR *PSC

CAUTION

If *PSC is programmed to 0, then the *SRE command causes a write cycle to nonvolatile memory. The nonvolatile memory has a finite number of write cycles (see Table A-2, Supplementary Characteristics). Programs that repeatedly write to nonvolatile memory can eventually exceed the maximum number of write cycles and may cause the memory to fail.

*STB?

Meaning and Type

Status Byte Device Status

Description

This query reads the Status Byte register, which contains the status summary bits and the Output Queue MAV bit. Reading the Status Byte register does not clear it. The input summary bits are cleared when the appropriate event registers are read (see "Chapter 8 - Status Reporting" for more information). The MAV bit is cleared at power on or by *CLS.

A serial poll also returns the value of the Status Byte register, except that bit 6 returns. Request for Service (RQS) instead of Master Status Summary (MSS). A serial poll clears RQS, but not MSS. When MSS is set, it indicates that the power supply has one or more reasons for requesting service.

Bit Configuration of Status Byte Register

Bit Position	7	6	5	4	3	2	1	0
Condition	OPER	MSS ¹ (RQS)	ESB	MAV	QUES	²	²	²
Bit Weight	128	64	32	16	8	4	2	1
ESB = Event status byte summary; MAV = Message available.								
MSS = Master status summary; OPER = Operation status summary.								
QUES = Questionable status summary; RQS = Request for service.								
¹ Also represents RQS. ² These bits are always zero.								

Query Syntax

***STB?**
Returned Parameters <NR1> (Register binary value)
Related Commands (None)

*TRG

Meaning and Type

Trigger Device Trigger

Description

This command generates a trigger when the trigger subsystem has **BUS** selected as its source. The command has the same affect as the Group Execute Trigger (<GET>) command.

Command Syntax	*TRG
Parameters	(None)
Query Syntax	(None)
Related Commands	ABOR CURR:TRIG INIT TRIG[:IMM] VOLT:TRIG <GET>

*TST?

Meaning and Type

Test Device Test

Description

This query causes the power supply to do a self-test and report any errors (see "Selftest Error Messages" in "Chapter 3 - Turn-On Checkout").

Query Syntax	*TST?
Returned Parameters	<NR1>
	0 Indicates power supply passed self-test.
	Nonzero Indicates an error code.
Related Commands	(None)

*WAI

Meaning and Type

Wait to Continue Device Status

Description

This command instructs the power supply not to process any further commands until all pending operations are completed. "Pending operations" are as defined under the ***OPC** command. ***WAI** can be aborted only by sending the power supply a GPIB **DCL** (Device Clear) command.

Command Syntax	*WAI
Parameters	(None)
Query Syntax	(None)
Related Commands	*OPC *OPC?

Description Of Subsystem Commands

Figure 7-2 is a tree diagram of the subsystem commands. Commands followed by a question mark (?) take only the query form. Except as noted in the syntax descriptions, all other commands take both the command and query form. The commands are listed in alphabetical order and the commands within each subsystem are grouped alphabetically under the subsystem.

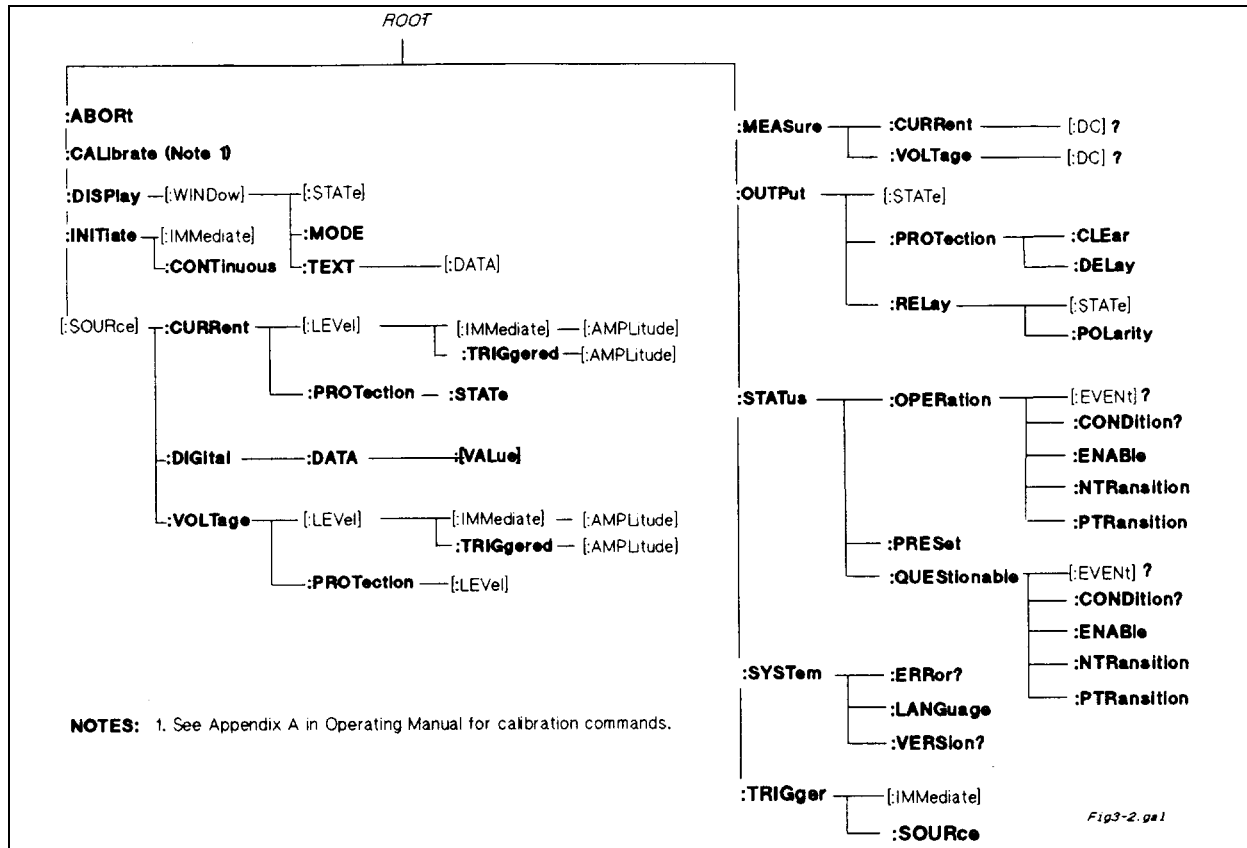

Figure 7-2. Subsystem Commands Tree Diagram

ABOR

This command cancels any trigger actions presently in process. Pending trigger levels are reset equal to their corresponding immediate values. **ABOR** also resets the WTG bit in the Operation Condition Status register (see "Chapter 8 - Status Reporting"). If **INIT:CONT ON** has been programmed, the trigger subsystem initiates itself immediately after **ABORt**, thereby setting WTG. **ABOR** is executed at power turn on and upon execution of ***RCL** or **RST**.

Command Syntax	ABORt
Parameters	(None)
Examples	ABOR
Query Syntax	(None)
Related Commands	INIT *RST *TRG TRIG

Calibration Commands

See Appendix B

Current Subsystem

This subsystem programs the output current of the power supply.

CURR CURR:TRIG

These commands set the immediate current level or the pending triggered current level of the power supply. The immediate level is the current programmed for the output terminals. The pending triggered level is a stored current value that is transferred to the output terminals when a trigger occurs. A pending triggered level is unaffected by subsequent **CURR** commands and remains in effect until the trigger subsystem receives a trigger or an **ABORT** command is given. If there is no pending **CURR:TRIG** level, then the query form returns the **CURR** level. In order for **CURR:TRIG** to be executed, the trigger subsystem must be initiated (see **INITiate**).

Command Syntax	[SOURce]:CURRent[:LEVel] [:IMMediate][:AMPLitude] <NRf+> [SOURce][:CURRent[:LEVel]:TRIGgered [:AMPLitude] <NRf+>
Parameters	Table 7-1
Default Suffix	A
*RST Value	Table 7-1
Examples	CURR 200 MA CURRENT:LEVEL 200 MA CURRENT:LEVEL:IMMEDIATE:AMPLITUDE 2.5 CURR:TRIG 20 CURRENT:LEVEL:TRIGGERED 20
Query Syntax	[SOURce]:CURRent[:LEVel] [:IMMediate][:AMPLitude]? [SOURce]:CURRent[:LEVel] [:IMMediate][:AMPLitude]? MAX [SOURce]:CURRent[:LEVel] [:IMMediate][:AMPLitude]? MIN [SOURce]:CURRent[LEVel]:TRIGgered [:AMPLitude]? [SOURce]:CURRent[LEVel]:TRIGgered [:AMPLitude]? MAX [SOURce]:CURRent[LEVel]:TRIGgered [:AMPLitude]? MIN
Returned Parameters	<NR3> CURR? and CURR:TRIG? return presently programmed immediate and triggered levels. If not triggered level is programmed, both returned values are the same. CURR? MAX and CURR? MIN return the maximum and minimum programmable immediate current levels. CURR:TRIG? MAX and CURR:TRIG? MIN return the maximum and minimum programmable triggered current levels.
Related Commands	For CURR *SAV *RCL *RST For CURR:TRIG ABOR CURR *RST

CURR:PROT:STAT

This command enables or disables the power supply overcurrent protection (OCP) function. If the overcurrent protection function is enabled and the power supply goes into constant-current operation, then the output is disabled and the Questionable Condition status register OC bit is set (see "Chapter 8 - Status Reporting"). An overcurrent condition can be cleared with the **OUTP:PROT:CLE** command after the cause of the condition is removed.

Command Syntax	[SOURce]:CURRent:PROTection:STATe <bool>
Parameters	0 1 OFF ON
*RST Value	OFF
Examples	CURR:PROT:STAT 0 CURRENT:PROTECTION:STATE OFF CURR:PROT:STAT 1 CURRENT:PROTECTION:STATE ON
Query Syntax	[SOURce]:CURRent:PROTection:STATe?
Returned Parameters	<NRI> 0 or 1
Related Commands	OUTP:PROT:CLE *RST

Digital Subsystem

This subsystem programs the control port on the back of the power supply when it is configured for Digital I/O operation.

DIG:DATA

This command sets and reads the power supply digital control port when that port is configured for Digital I/O operation. Configuring of the port is done via an internal jumper (see Appendix F). The port has three signal pins and a digital ground pin. Pins 1 and 2 are output pins controlled by bits 0 and 1. Pin 3 is controlled by bit 3 and can be programmed to serve either as an input or an output. Pin 4 is the digital ground.

Bit position 2 normally serves as an output. To change it to an input, it must first be programmed high. The **DIG:DATA?** query returns the last programmed value in bits 0 and 1 and the value read at pin 3 in bit 2. The bits are turned on and off in straight binary code as follows:

Digital I/O Port Programming Chart

Value	Bit Configuration			Pin Configuration ¹				Value	Bit Configuration			Pin Configuration ¹			
	0	1	2	1	2	3	4		0	1	2	1	2	3	4
0	0	0	0	Lo	Lo	Output	Gnd	4	0	0	1	Lo	Lo	Input	Gnd
1	1	0	0	Hi	Lo	Output	Gnd	5	1	0	1	Hi	Lo	Input	Gnd
2	0	1	0	Lo	Hi	Output	Gnd	6	0	1	1	Lo	Hi	Input	Gnd
3	1	1	0	Hi	Hi	Output	Gnd	7	1	1	1	Hi	Hi	Input	Gn

¹Pins 1 and 2 are always outputs

Command Syntax	[SOURCE]:DIGital:DATA[:VALue] <NRf>
Parameters	0 to 7
Suffix	(None)
*RST Value	0
Examples	DIG:DATA 7 DIGITAL:DATA:VALUE 7
Query Syntax	[SOURCE]:DIGital:DATA?
Returned Parameters	<NR1> Values from 0 to 7
Related Commands	*RST *RCL *SAV

Display Subsystem

This subsystem controls the state and output of the alphanumeric portion of the display.

DISP

Enables or disables the display. When disabled, the display characters are blank. The annunciators are not affected by this command.

Command Syntax	DISPlay[:WINDow][:STATe] <bool>
Parameters	0 1 OFF ON
Suffix	(None)
*RST Value	ON
Examples	DISP ON DISPLAY:STATE ON
Query Syntax	DISPlay[:WINDow][STATe]?
Returned Parameters	<NR1> 0 or 1
Related Commands	DISP:MODE DISP:TEXT *RST

DISP:MODE

Switches the display between its normal metering mode and a mode in which it displays text sent by the user. The command uses the character data <CRD> format.

Command Syntax	DISPlay[:WINDow]:MODE NORMAl TEXT
Parameters	<CRD> NORMAl TEXT
*RST Value	NORM
Examples	DISP:MODE NORM DISPLAY:MODE NORMAL DISPLAY:WINDOW:MODE TEXT
Query Syntax	DISPlay[:WINDow]:MODE?
Returned Parameters	<CRD> <i>NORMAL</i> or <i>TEXT</i>
Related Commands	DISP DISP:TEXT *RST

DISP:TEXT

Allows character strings to be sent to display. The characters will be displayed when the display mode is TEXT. The LCD has the following character set:

LCD Character Set

uppercase letters	A through Z (Case-sensitive entry)
digits	0 through 9
punctuation	_ “ \$ < > + - / = ? . : ,
blank space	

A display is capable of showing up to 12 characters. However, the three punctuation characters do not count toward the 12-character limit when they are preceded by an alphanumeric character. When punctuation characters are included, then the maximum number of characters (alphanumeric + punctuation) that can be displayed is 15. If it exceeds the display capacity, a message will be truncated to fit and no error message will be generated. If any character in the message is not a member of the above character set, the character will not be rejected but will be displayed as a "starburst" (all 16 segments of the character will light).

Command Syntax	DISPlay[:WINDow]:TEXT [:DATA] <STR>
Parameters	(See LCD character set)
*RST Value	' '
Examples	DISP:TEXT "DEFAULT_MODE" DISPLAY:WINDOW:TEXT:DATA '533.2E-1VOLTS'
Query Syntax	DISPlay[:WINDow]:TEXT?
Returned Parameters	<STR> (Last programmed text string)
Related Commands	DISP DISP:MODE *RST

Note *IEEE Standard Digital Interface* for Programmable Instrumentation requires that a string be enclosed in either single (') or double (") quotes.

Initiate Subsystem

This subsystem enables the trigger system.

INIT INIT:CONT

When a trigger is enabled with this command, an event on a selected trigger source causes the specified triggering action to occur. If the trigger subsystem is not enabled, all trigger commands are ignored. If **INIT:CONT** is **OFF**, then **INIT** enables the trigger subsystem only for a single trigger action. The subsystem must be enabled prior to each subsequent trigger action. If **INIT:CONT** is **ON**, then the trigger subsystem is continuously enabled and **INIT** is redundant.

Command Syntax	INITiate[:IMMediate] INITiate:CONTinuous <bool>
Parameters	For INIT[:IMM] (None) For INIT:CONT 0 1 OFF ON
*RST Value	OFF
Examples	INIT INITIATE:IMMEDIATE INIT:CONT 1 INITIATE:CONTINUOUS 1
Query Syntax	For INIT[:IMM] (None) For INIT:CONT INIT:CONT?
Returned Parameters	<NR1> <i>0/1</i>
Related Commands	ABOR <GET> *RST TRIG *TRG

Measure Subsystem

This subsystem returns output measurements.

MEAS:CURRE? MEAS:VOLT?

These queries return the voltage and current measured at the power supply's sense terminals.

Query Syntax	MEASure:CURRent[:DC]? MEASure:VOLTage[:DC]?
Parameters	(None)
Default Suffix	A for MEAS:CURRE? V for MEAS:VOLT?
Examples	MEAS:CURRE? MEAS:VOLT? MEASURE:VOLTAGE:DC? MV
Returned Parameters	<NR3>

Output Subsystem

This subsystem controls the power supply's voltage and current outputs and an optional output relay.

OUTP

This command enables or disables the power supply output. The state of a disabled output is a condition of zero output voltage and a model-dependent minimum source current (see Table 7-1). The query form returns the output state.

Command Syntax	OUTPut[:STATe] <bool>
Parameters	0 OFF 1 ON
Suffix	(None)
*RST Value	0
Examples	OUTP 1 OUTPUT:STATE ON
Query Syntax	OUTPut(:STATe)?
Returned Parameters	<NR1> 0 or 1
Related Commands	*RST *RCL *SAV

OUTP:PROT:CLE

OUTP:PROT:DEL

These output protection commands do the following:

OUTP:PROT:CLE Clears any OV (overvoltage), OC (overcurrent, unless set via external voltage control), OT (overtemperature), or RI (remote inhibit) protection features. After this command, the output is restored to the state it was in before the protection feature occurred.

OUTP:PROT:DEL Sets the time between the programming of an output change that produces a CV, CC, or UNREG condition and the recording of that condition by the Status Operation Condition register. The delay prevents the momentary changes in power supply status that can occur during reprogramming from being registered as events by the status subsystem. Since the delay applies to CC status, it also delays the OCP (overcurrent protection) feature. The OVP (overvoltage protection) feature is not affected by this delay.

Examples	OUTP:PROT:CLE OUTPUT:PROTECTION:CLEAR OUTPUT:PROTECTION:DELAY 75E-1 OUTP:PROT:DEL MIN OUTPUT:PROT:DELAY MAX
Query Syntax	OUTP:PROT:CLE (None) OUTPut:PROTection:DELAy? OUTPut:PROTection:DELAy? MIN OUTPut:PROTection:DELAy? MAX
Returned Parameters	<NR3> OUTP:PROT:DEL? returns value of programmed delay. OUTP:PROT:DEL? MIN and OUTP:PROT:DEL? MAX return the minimum and maximum programmable delays.
Related Commands	OUTP:PROT:CLE (None) OUTP:PROT:DEL *RST *RCL *SAV

OUTP:REL

This command is valid only if the power supply is configured for the optional relay connector. Programming **ON** closes the relay contacts; programming **OFF** opens them. The relay is controlled independently of the output state. If the power supply is supplying power to a load, that power will appear at the relay contacts during switching. If the power supply is not configured for the relay option, sending either relay command generates an error.

Command Syntax	OUTPut:RELAy[:STATe] <bool>
Parameters	0 1 OFF ON
*RST Value	0
Examples	OUTP:REL 1 OUTP:REL OFF
Query Syntax	OUTPput:RELAy?
Returned Parameters	0 1
Related Commands	OUTP[:STAT] *RCL *SAV

OUTP:REL:POL

This command is valid only if the power supply is configured for the optional relay connector. Programming **NORMAL** causes the relay output polarity to be the same as the power supply output. Programming **REVERSE** causes the relay output polarity to be opposite to that of the power supply output. If **OUTP[:STAT] = ON** when either relay command is sent, the power supply output voltage is set to 0 during the time that the relays are changing polarity. If the power supply is not configured for the relay option, sending either relay command generates an error.

Command Syntax	OUTPut:RELAy:POLarity <CRD>
Parameters	NORMal REVerse
*RST Value	NORM
Examples	OUTP:REL:POL NORM
Query Syntax	OUTPput:RELAy:POLarity?
Returned Parameters	NORM REV
Related Commands	OUTP[:STAT] *RCL *SAV

Status Subsystem

This subsystem programs the power supply status registers. The power supply has three groups of status registers; **Operation**, **Questionable**, and **Standard Event**. The Standard Event group is programmed with Common commands as described in "Chapter 8 - Status Reporting". The Operation and Questionable status groups each consist of the Condition, Enable, and Event registers and the NTR and PTR filters.

STAT:PRES

This command sets all defined bits in the Status Subsystem PTR registers and clears all bits in the subsystem NTR and Enable registers. STAT:OPER:PTR is set to 1313 and STAT:QUES:PTR is set to 1555.

Command Syntax	STATus:PRESet
Parameters	(None)
Examples	STAT:PRES STATUS:PRESET
Query Syntax	(None)
Related Commands	(None)

Status Operation Registers

The bit configuration of all Status Operation registers is shown in the following table. See "Chapter 8 - Status Reporting" for more explanation of these registers.

Bit Configuration of Operation Registers

Bit Position	15-12	11	10	9	8	7	6	5	4	3	2	1	0
Bit Name	NU	NU	CC	NU	CV	NU	NU	WTG	NU	NU	NU	NU	CAL
Bit Weight		2048	1024	512	256	128	64	32	16	8	4	2	1

CAL = Interface is computing new calibration constants; CC = The power module is in constant current mode.
 CV = The power module is in constant voltage mode; NU = (Not used); WTG = Interface is waiting for a trigger.

STAT:OPER?

This query returns the value of the Operation Event register. The Event register is a read-only register which holds (latches) all events that are passed by the Operation NTR and/or PTR filter. Reading the Operation Event register clears it.

Query Syntax	STATus:OPERtion[:EVENT]?
Parameters	(None)
Returned Parameters	<NR1> (Register Value)
Examples	STAT:OPER? STATUS:OPERATIOBAL:EVENT?
Related Commands	*CLS STAT:OPER:NTR STAT:OPER:PTR

STAT:OPER:COND?

This query returns the value of the Operation Condition register. That is a read-only register which holds the real-time (unlatched) operational status of the power supply.

Query Syntax	STATus:OPERation:CONDition?
Parameters	(None)
Examples	STAT:OPER:COND? STATUS:OPERATION:CONDITION?
Returned Parameters	<NR1> (Register value)
Related Commands	(None)

STAT:OPER:ENAB

This command and its query set and read the value of the Operational Enable register. This register is a mask for enabling specific bits from the Operation Event register to set the operation summary bit (OPER) of the Status Byte register. This bit (bit 7) is the logical OR of all the Operational Event register bits that are enabled by the Status Operation Enable register.

Command Syntax	STATus:OPERation:ENABLE <NRf>
Parameters	0 to 32727
Suffix	(None)
Default Value	0
Examples	STAT:OPER:ENAB 1312 STAT:OPER:ENAB 1 STATUS:OPERATION:ENABLE?
Query Syntax	STATus:OPERation:ENABLE?
Returned Parameters	<NR1> (Register value)
Related Commands	STAT:OPER:EVEN

STAT:OPER:NTR STAT:OPER:PTR

These commands set or read the value of the Operation NTR (Negative-Transition) and PTR (Positive-Transition) registers. These registers serve as polarity filters between the Operation Enable and Operation Event registers to cause the following actions:

- When a bit in the Operation NTR register is set to 1, then a 1-to-0 transition of the corresponding bit in the Operation Condition register causes that bit in the Operation Event register to be set.
- When a bit of the Operation PTR register is set to 1, then a 0-to-1 transition of the corresponding bit in the Operation Condition register causes that bit in the Operation Event register to be set.
- If the same bits in both NTR and PTR registers are set to 1, then *any transition* of that bit at the Operation Condition register sets the corresponding bit in the Operation Event register.
- If the same bits in both NTR and PTR registers are set to 0, then *no transition* of that bit at the Operation Condition register can set the corresponding bit in the Operation Event register.

Note Setting a bit in the value of the PTR or NTR filter can of itself generate positive or negative events in the corresponding Operation Event register.

Command Syntax	STATus:OPERtion:NTRansition <NRf> STATus:OPERtion:PTRansition <NRf>
Parameters	0 to 32727
Suffix	(None)
Default Value	0
Examples	STAT:OPER:NTR 32 STAT:OPER:PTR 1312
Query Syntax	STAT:OPER:NTR? STAT:OPER:PTR?
Returned Parameters	<NR1> (Register value)
Related Commands	STAT:OPER:ENAB

Status Questionable Registers

Bit Configuration of Questionable Registers

Bit Position	15-11	10	9	8	7	6	5	4	3	2	1	0
Condition	NU	UNR	RI	NU	NU	NU	NU	OT	NU	NU	OC	OV
Bit Weight		1024	512	256	128	64	32	16	8	4	2	1

NU = (Not used); OC = Overcurrent protection circuit has tripped.
 OT = Overtemperature status condition exists; OV = Overvoltage protection circuit has tripped.
 RI = Remote inhibit is active; UNR = Power supply output is unregulated.

Note: See "Chapter 4 - Status Reporting" for more explanation of these registers.

STAT:QUES?

This query returns the value of the Questionable Event register. The Event register is a read-only register which holds (latches) all events that are passed by the Questionable NTR and/or PTR filter. Reading the Questionable Event register clears it.

Query Syntax	STATus:QUESTionable[:EVENT]?
Parameters	(None)
Returned Parameters	<NR1> (Register Value)
Examples	STAT:QUES? STATUS:QUESTIONABLE:EVENT?
Related Commands	*CLS STAT:QUES:ENAB STAT:QUES:NTR STAT:QUES:PTR

STAT:QUES:COND?

This query returns the value of the Questionable Condition register. That is a read-only register which holds the real-time (unlatched) questionable status of the power supply.

Query Syntax	STATus:QUESTIONable:CONDition?
Parameters	(None)
Examples	STAT:QUES:COND? STATUS:QUESTIONABLE:CONDITION?
Returned Parameters	<NR1> (Register value)
Related Commands	(None)

STAT:QUES:ENAB

This command and its query set and read the value of the Questionable Enable register. This register is a mask for enabling specific bits from the Questionable Event register to set the questionable summary bit (QUES) of the Status Byte register. This bit (bit 3) is the logical OR of all the Questionable Event register bits that are enabled by the Questionable Status Enable register.

Command Syntax	STATus:QUESTIONable:ENABLE <NRf>
Parameters	0 to 32727
Suffix	(None)
Default Value	0
Examples	STAT:QUES:ENAB 20 STAT:QUES:ENAB 16
Query Syntax	STATus:QUESTIONable:ENABLE?
Returned Parameters	<NR1> (Register value)
Related Commands	STAT:QUES?

STAT:QUES:NTR

STAT:QUES:PTR

These commands allow you to set or read the value of the Questionable NTR (Negative-Transition) and PTR (Positive-Transition) registers. These registers serve as polarity filters between the Questionable Enable and Questionable Event registers to cause the following actions:

- When a bit of the Questionable NTR register is set to 1, then a 1-to-0 transition of the corresponding bit of the Questionable Condition register causes that bit in the Questionable Event register to be set.
- When a bit of the Questionable PTR register is set to 1, then a 0-to-1 transition of the corresponding bit in the Questionable Condition register causes that bit in the Questionable Event register to be set.
- If the same bits in both NTR and PTR registers are set to 1, then *any transition* of that bit at the Questionable Condition register sets the corresponding bit in the Questionable Event register.
- If the same bits in both NTR and PTR registers are set to 0, then *no transition* of that bit at the Questionable Condition register can set the corresponding bit in the Questionable Event register.

Note Setting a bit in the PTR or NTR filter can of itself generate positive or negative events in the corresponding Questionable Event register.

Command Syntax	STATus:QUESTIONable:NTRansition <NRf> STATus:QUESTIONable:PTRansition <NRf>
Parameters	0 to 32727
Suffix	(None)
Default Value	0
Examples	STAT:QUES:NTR 16 STATUS:QUESTIONABLE:PTR 512
Query Syntax	STAT:QUES:NTR? STAT:QUES:PTR?
Returned Parameters	<NR1> (Register value)
Related Commands	STAT:QUES:ENAB

System Commands

System commands query error messages and software versions, and program system language functions.

SYST:ERR?

This query returns the next error number followed by its corresponding error message string from the remote programming error queue. The queue is a FIFO (first-in, first-out) buffer that stores errors as they occur. As it is read, each error is removed from the queue. When all errors have been read, the query returns **0,NO ERROR**. If more errors are accumulated than the queue can hold, the last error in the queue will be **-350,TOO MANY ERRORS** (see Appendix D for other error codes).

You can use the power supply front panel **Error** key to read errors from the queue. Errors generated at the front panel are not put into the queue but appear immediately on the display.

Query Syntax	SYSTem:ERRor?
Parameters	(None)
Returned Parameters	<NRI>,<SRD>
Examples	SYST:ERR? SYSTEM:ERROR?
Related Commands	(None)

SYST:LANG

This command switches the interface between its SCPI (TMSL) command language and its compatibility language. The compatibility language is provided for emulation of older power supply systems and is described in Appendix G. Sending the command causes:

- The alternate language to become active and to be stored in nonvolatile memory.
- The power supply to reset to the state stored in Location 0.

If the power supply is shut off, it will resume operation in the last-selected language when power is restored.

Command Syntax	SYSTem:LANGuage <string> <i>Syntax is the same, regardless of the present language.</i>
Parameters	TMSL COMPatibility Note: Parameter TMSL must be used in place of <i>SCPI</i> .
Default Value	<i>TMSL or last selected language.</i>
Examples	SYST:LANG TMSL SYSTEM:LANGUAGE COMPATIBILITY
Query Syntax	SYSTem:LANGuage?
Returned Parameters	<CRD> <i>TMSL COMP</i>
Related Commands	(None)

SYST:VERS?

This query returns the SCPI version number to which the power supply complies. The returned value is of the form YYYY.V, where YYYY represents the year and V is the revision number for that year.

Query Syntax	SYSTem:VERSion?
Parameters	(none)
Returned Parameters	<NR2>
Examples	SYST:VERS? SYSTEM:VERSION?
Related Commands	(None)

Trigger Subsystem

This subsystem controls remote triggering of the power supply.

TRIG

When the trigger subsystem is enabled, **TRIG** generates a trigger signal. The trigger will then:

1. Initiate a pending level change as specified by **CURR[:LEV]:TRIG** or **VOLT[:LEV]:TRIG**.
2. Clear the WTG bit in the Status Operation Condition register.
3. If **INIT:CONT** has been given, the trigger subsystem is immediately re-enabled for subsequent triggers. As soon as it is cleared, the WTG bit is again set to 1.

Command Syntax	TRIGger[:IMMediate]
Parameters	(None)
Examples	TRIG TRIGGER:IMMEDIATE
Query Syntax	(None)
Related Commands	ABOR CURR:TRIG INIT *TRG VOLT:TRIG

TRIG:SOUR

This command selects the trigger source. Since the power supply has no other trigger source than the GPIB bus, this command need not be used. It is included in the command set to provide programming compatibility with other instruments (such as the Keysight Electronic Load family) that may have more than one trigger source.

Command Syntax	TRIGger:SOURce <CRD>
Parameters	BUS
*RST Value	BUS
Examples	TRIG:SOUR BUS TRIGGER:SOURCE BUS
Query Syntax	TRIGger:SOURce?
Returned Parameters	<i>BUS</i>
Related Commands	*RST *TRG TRIG[:IMM]

Voltage Subsystem

This subsystem programs the output voltage of the power supply.

VOLT VOLT:TRIG

These commands set the immediate voltage level or the pending triggered voltage level of the power supply. The immediate level is the voltage programmed for the output terminals. The pending triggered level is a stored voltage value that is transferred to the output terminals when a trigger occurs. A pending triggered level is unaffected by subsequent **VOLT** commands and remains in effect until the trigger subsystem receives a trigger or an **ABORT** command is given. If there is no pending **VOLT:TRIG** level, then the query form returns the **VOLT** level. In order for **VOLT:TRIG** to be executed, the trigger subsystem must be initiated (see **INITiate**).

	Command Syntax	[SOURce]:VOLTage[:LEVel][:IMMediate][:AMPLitude] <NRf+> [SOURce][:VOLTage[:LEVel]:TRIGgered[:AMPLitude] <NRf+>
	Parameters	Table 7-1
	Default Suffix	V
	*RST Value	Table 7-1
	Examples	VOLT 200 MA VOLTAGE:LEVEL 200 MA VOLTAGE:LEVEL:IMMEDIATE:AMPLITUDE 2.5 VOLT:TRIG 20 VOLTAGE:LEVEL:TRIGGERED 20
MAX	Query Syntax	[SOURce]:VOLTage[:LEVel][:IMMediate][:AMPLitude]? [SOURce]:VOLTage[:LEVel][:IMMediate][:AMPLitude]? [SOURce]:VOLTage[:LEVel][:IMMediate][:AMPLitude]? MIN [SOURce]:VOLTage[LEVel]:TRIGgered[:AMPLitude]? [SOURce]:VOLTage[LEVel]:TRIGgered[:AMPLitude]? MAX [SOURce]:VOLTage[:LEVel]:TRIGgered[:AMPLitude]? MIN
	Returned Parameters	<NR3> VOLT? and VOLT:TRIG? return presently programmed immediate and triggered levels. If not triggered level is programmed, both returned values are the same. VOLT? MAX and VOLT? MIN return the maximum and minimum programmable immediate voltage levels. VOLT:TRIG? MAX and VOLT:TRIG? MIN return the maximum and minimum programmable triggered voltage levels.
	Related Commands	For VOLT *SAV *RCL *RST For VOLT:TRIG ABOR VOLT *RST

VOLT:PROT

This command sets the overvoltage protection (OVP) level of the power supply. If the output voltage exceeds the OVP level, then the power supply output is disabled and the Questionable Condition status register OV bit is set (see "Chapter 8 - Status Reporting"). An overvoltage condition can be cleared with the **OUTP:PROT:CLE** command after the condition that caused the OVP trip is removed. The OVP always trips with zero delay and is unaffected by the **OUTP:PROT:DEL** command.

	Command Syntax	[SOURce]:VOLTage:PROTection[:LEVel] <NRf+>
	<i>*Alternate Syntax</i>	[SOURce]:VOLTage:PROTection:AMPLitude <NRf+>
	Parameters	Table 7-1
	Default Suffix	V
	*RST Value	MAX
	Examples	VOLT:PROT 21.5 VOLT:PROT:LEV MAX VOLTAGE:PROTECTION:LEVEL 145E-1
	Query Syntax	[SOURce]:VOLTage:PROTection[:LEVel]? [SOURce]:VOLTage:PROTection [:LEVel]? MIN [SOURce]:VOLTage:PROTection [:LEVel]? MAX
	Returned Parameters	<NR3> VOLT:PROT? returns presently programmed OVP level. VOLT:PROT? MAX and VOLT:PROT? MIN return the maximum and minimum programmable OVP levels.
	Related Commands	OUTP:PROT:CLE *RST *SAV *RCL
		* Available to accommodate earlier power supply programs.

Command Summary

This summary lists all power supply subsystem commands in alphabetical order, followed by all common commands in alphabetical order. See Table 7-1 for the command parameters accepted by the power supply.

Command Summary	
Command	Parameters
Subsystem Commands	
MEAS:CURR[:DC]? MEAS:VOLT[:DC]?	(none) (none)
OUTP[:STAT] OUTP[:STAT]? OUTP:PROT:CLE OUTP:PROT:DEL OUTP:PROT:DEL? OUTP:REL[:STAT] OUTP:REL[:STAT]? OUTP:REL:POL OUTP:REL:POL?	0 1 OFF ON (none) (none) 0 to 32.767 MIN MAX (none) MIN MAX 0 1 2OFF ON+ (none) NORM REV (none)
STAT:OPER:COND? STAT:OPER:ENAB STAT:OPER:ENAB? STAT:OPER[:EVEN]? STAT:OPER:NTR STAT:OPER:NTR? STAT:OPER:PTR STAT:OPER:PTR? STAT:PRES STAT:QUES:COND? STAT:QUES:ENAB STAT:QUES:ENAB? STAT:QUES[:EVEN]?	(none) <NRf> (none) (none) <NRf> (none) <NRf> (none) (none) (none) <NRf> (none) (none) (none)
SYST:ERR? SYST:LANG SYST:LANG? SYST:VERS?	(none) TMSLICOMP (none) (none)
TRIG[:IMM] TRIG:SOUR TRIG:SOUR?	(none) BUS (n one)
[SOUR]:VOLT[:LEV][:IMM][:AMPL] (SOUR):VOLT[:LEV][:IMM][:AMPL]? [SOUR]:VOLT[:LEV]:TRIG[:AMPL] (SOUR):VOLT[:LEV]:TRIG[:AMPL]? [SOUR]:VOLT:PROT[:LEV] [SOUR]:VOLT:PROT[:LEV]?	<NRf+>[suffix] (none) MIN MAX <NRf+>[suffix] (none) MIN MAX <NRf+>[suffix] <NRf+>[suffix]

Command Summary

Command	Parameters
Subsystem Commands	
ABOR	(none)
CAL	(See Appendix A in the Operating Manual)
[SOUR]:CURR[:LEV][:IMM][:AMPL]	<NRf+>[suffix]
[SOUR]:CURR[:LEV][:IMM][:AMPL]?	(none) MIN MAX
[SOUR]:CURR[:LEV]:TRIG[:AMPL]	<NRf+>[suffix]
[SOUR]:CURR[:LEV]:TRIG[:AMPL]?	(none) MIN MAX
[SOUR]:CURR:PROT:STAT	0 1 ON OFF
(SOUR):CURR:PROT:STAT?	(none)
[SOUR]:DIG:DATA[:VAL]	<NRf>
[SOUR]:DIG:DATA[:VAL]?	(none)
DISP[WIND]:MODE	NORM TEXT
DISP(WIND):MODE?	(none)
DISP[:WIND][:STAT]	0 1 OFF ON
DISP[:WIND][:STAT]?	(none)
DISP[:WIND]:TEXT[:DATA]	<STR>
DISP[:WIND]:TEXT[:DATA]?	(none)
INIT[:IMM]	(none)
INIT:CONT	0 1 OFF ON
INIT:CONT?	(none)

Common Commands

Command	Parameters
*CLS	(None)
*ESE	<NRf>
*ESE?	(None)
*ESR?	(None)
*IDN?	(None)
*OPC	(None)

Command	Parameters
*OPC?	(None)
*PSC	<bool>
*PSC?	(None)
*RCL	<NRf>
*RST	(None)
*SAV	<NRf>

Command	Parameters
*SRE	<NRf>
*SRE?	(None)
*STB?	(None)
*TRG	(None)
*TST?	(None)
*WAI	(None)

Programming Parameters

Table 7-1 list the programming parameters. For programming accuracy and resolution, refer to Appendix A.

Table 7-1. Power supply Programming Parameters (see note)

Parameter	
CURR[:LEV] MAX and CURR[:LEV]:TRIG MAX (Programming range is 0 to MAX)	30.71 A
*RST Current Value	0.14 A
OUTP:PROT:DEL *RST Value	0 to 32.727 s (MAX) 200 ms
VOLT[:LEV] MAX and VOLT[:LEV]:TRIG MAX (Programming range is 0 to MAX)	81.9 V
*RST Voltage Value	0 V
VOLT:PROT MAX (Programming range is 0 to MAX)	96.0 V
*RST OVP value	MAX

Status Reporting

Power supply Status Structure

Figure 8-1 shows the status register structure of the power supply. The Standard Event, Status Byte, and Service Request Enable registers and the Output Queue perform standard GPIB functions as defined in the *IEEE 488.2 Standard Digital Interface* for Programmable Instrumentation. The Operation Status and Questionable Status registers implement status functions specific to the power supply. Table 8-2 and Figure 8-1 show the bit configuration of each status register.

Operation Status Group

Register Functions

The Operation Status registers record signals that occur during normal operation. The group consists of the following registers:

- A Condition register that holds real-time status of the circuits being monitored. It is a read-only register.
- A PTR/NTR (positive transition/negative transition) Filter that functions as described under **STAT:OPER:NTR|PTR COMMANDS** in "Chapter 3 - Language Dictionary". This is a read/write register.
- An Event register that latches any condition that is passed through the PTR or NTR filters. Reading the Event register clears it.
- An Enable register that functions as described under **STAT:OPER:ENAB** in "Chapter 3 - Language Dictionary". This is a read/write register.

The outputs of the Operation Status group are logically-ORed into the OPER(ation) summary bit (7) of the Status Byte register.

Register Commands

Commands that access this group are derived from the **STAT:OPER** commands described in Chapter 7 - "Language Dictionary" and summarized in Table 8-1.

Table 8-1. Status Operation Commands

Register	Command	Query	Cleared By
Condition	(None)	STAT:OPER:COND?	Cannot be cleared
PTR Filter	STAT:OPER:PTR <NRf>	STAT:OPER:PTR?	Programming 0
NTR Filter	STAT:OPER:NTR <NRf>	STAT:OPER:NTR?	Programming 0 or STAT:PRES
Event	(None)	STAT:OPER:EVEN?	Reading or *CLS
Enable	STAT:OPER:ENAB <NRf>	STAT:OPER:ENAB?	Programming 0

Table 8-2. Bit Configurations of Status Registers

Bit	Signal	Meaning	Bit	Signal	Meaning
Operation Status Group			Standard Event Status Group		
0	CAL	The interface is computing new calibration constants.	0	OPC	Operation complete.
5	WTG	The interface is waiting for a trigger.	2	QYE	Query error.
8	CV	The power module is in constant voltage mode.	3	DDE	Device-dependent error.
10	CC	The power module is in constant current mode.	4	EXE	Execution error.
Questionable Status Group			5	CME	Command error.
0	OV	The power module overvoltage protection circuit has tripped.	7	PON	Power on.
1	OC	The power module overcurrent protection circuit has tripped.	Status Byte and Service Request Enable Registers		
4	OT	The power module has an overtemperature condition.	3	QUES	Questionable status summary bit.
9	RI	The power module remote inhibit state is active.	4	MAV	Message Available summary bit.
10	UNR	The power module output is unregulated.	5	ESB	Event Status summary bit.
			6	MSS	Master Status summary bit.
			7	RQS	Request Service bit.
			7	OPER	Operation status summary bit.

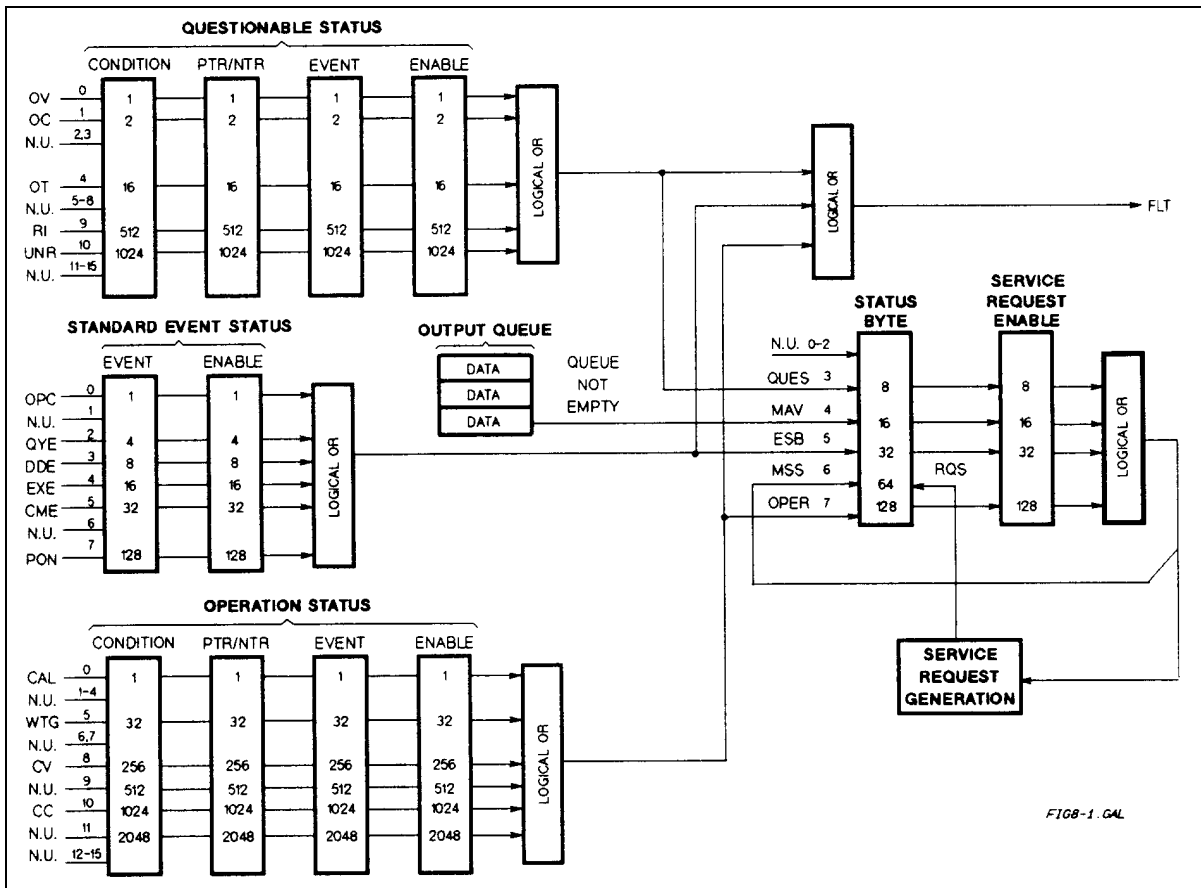

Figure 8-1. Power supply Status Model

Questionable Status Group

Register Functions

The Questionable Status registers record signals that indicate abnormal operation of the power supply. As shown in Figure 8-1, the group consists of the same type of registers as the Status Operation group. The outputs of the Questionable Status group are logically-ORed into the QUES(tionable) summary bit (3) of the Status Byte register.

Register Commands

Programming for this group is derived from the **STAT:QUES** commands described in "Chapter 7 - Language Dictionary" and summarized in Table 8-3.

Table 8-3. Status :Questionable Commands

Register	Command	Query	Cleared By
Condition	(None)	STAT:QUES:COND?	Cannot be cleared
PTR Filter	STAT:QUES:PTR <NRf>	STAT:QUES:PTR?	Programming 0
NTR Filter	STAT:QUES:NTR <NRf>	STAT:QUES:NTR?	Programming 0 or STAT:PRES
Event	(None)	STAT:QUES:EVEN?	Reading or *CLS
Enable	STAT:QUES:ENAB <NRf>	STAT:QUES:ENAB?	Programming 0

Standard Event Status Group

Register Functions

This group consists of an Event register and an Enable register that are programmed by common commands. The Standard Event Status Event register latches events relating to interface communication status (see Table 8-1). It is a read-only register that is cleared when read.

Read query ***ESR!**
Cleared by ***CLS *ESR?**

The Standard Event Status Enable register functions similarly to the enable registers of the Operation and Questionable status groups.

Register Commands

The common ***ESE** command programs specific bits in the Standard Event Status Enable register. Because the power supply implements ***PSC**, the register is cleared at power on if ***PSC = 1**. ***ESR?** reads the Standard Event Status Event register and reading the register clears it.

Programmed by ***ESE <NRf>**
Read query ***ESE?**
Cleared by ***ESE 0**

Status Byte Register

This register summarizes the information from all other status groups as defined in the "IEEE 488.2 Standard Digital Interface for Programmable Instrumentation" standard. The bit configuration is shown in Table 8-1. The register can be read either by a serial poll or by ***STB?**. Both methods return the same data, except for bit 6. Sending ***STB?** returns MSS in bit 6, while poring the register returns **RQS** in bit 6.

The MSS Bit

This is a real-time (unlatched) summary of all Status Byte register bits that are enabled by the Service Request Enable register. MSS is set whenever the power supply has at least one reason (and possibly more) for requesting service. Sending ***STB?** reads the MSS in bit position 6 of the response. No bits of the Status Byte register are cleared by reading it.

The RQS Bit

Whenever the power supply requests service, it sets the SRQ interrupt line true and latches RQS into bit 6 of the Status Byte register. When the controller services the interrupt, RQS is cleared inside the register and returned in bit position 6 of the response. The remaining bits of the Status Byte register are not disturbed.

Output Queue

The Output Queue is a first-in, first-out (FIFO) data register that stores power supply-to-controller messages until the controller reads them. Whenever the queue holds one or more bytes, it sets the MAV bit (4) of the Status Byte register. If too many unread error messages are accumulated in the queue, a system error message is generated (see Table 9-1 in "Chapter 9 - Error Messages"). The Output Queue is cleared at power on and by ***CLS**.

Service Request Enable Register

This register is a mask that determines which bits from the Status Byte register will be ORed to generate a service request (SRQ). The register is programmed with the ***SRE** common command. When the register is cleared, no service requests can be generated to the controller.

Inhibit/Fault Indicator

The remote inhibit (INH) and discrete fault (FLT) indicators are implemented through their respective INH and FLT connections on the rear panel. Refer to Appendix F for more information.

RI (Remote Inhibit)

Whenever a remote inhibit signal is received at the digital port (see Appendix F - "Digital Port Functions"), the power supply will receive an RI event at the Questionable Status register. By programming the status subsystem, you may use RI to generate a service request (SRQ) to the controller and/or to create a DFI output at the digital port. By using RI/DFI in this way, you can chain the power supplies to create a serial shutdown in response to the INH input.

DFI (Discrete Fault Indicator)

Whenever a fault is detected in the power supply, it is capable of generating a FLT signal at the digital port (see Appendix F - "Digital Port Functions"). The source for the DFI signal can be any Questionable, Operation, or Standard Event status event (see Figure 8-1).

Initial Conditions At Power On

Status Registers

When the power supply is turned on, a sequence of commands initializes the status registers. For the factory-default *RST power-on state, Table 8-4 shows the register states and corresponding power-on commands.

Table 8-4. Default Power On Register States

Register	Condition	Caused By
Operation PTR; Questionable PTR	All bits = 1	STAT:PRE
Operation NTR; Questionable NTR	All bits = 0	STAT:PRE
Operation Event; Questionable Event	All bits = 0	*CLS
Operation Enable; Questionable Enable	All bits = 0	STAT:PRE
Standard Event Status Enable	All bits = 0 ¹	*ESE 0
Status Byte	All bits = 0	*CLS
Status Request Enable	All bits = 0 ¹	*SRE 0
Output Queue	Cleared	*CLS

¹If PSC=1. If PSC = 0, then the last previous state before turn on is recalled. The value of PSC is stored in nonvolatile memory.

The PON (Power-On) Bit

The PON bit in the Standard Event register is set whenever the power supply is turned on. The most common use for PON is to generate an SRQ at power on following an unexpected loss of power. To do this, bit 7 of the Standard Event Enable register must be set so that a power-on event registers in the ESB (Standard Event Summary Bit). Also, bit 5 of the Service Request Enable register must be set to permit an SRQ to be generated. The commands to accomplish these two conditions are:

***ESE 128**
***SRE 32**

If *PSC is programmed to **0**, the contents of the Standard Event Enable and Service Request Enable registers are saved in nonvolatile memory and recalled at power on. This allows a PON event to generate SRQ at power on. Programming *PSC to **1** prevents these registers from being saved and they are cleared at power on. This prevents a PON event from generating SRQ at power on.

Status Register Programming Examples

Note These examples are generic SCPI commands. See "Chapter 6 - Remote Programming" for information about encoding the commands as language strings.

Determining the Cause of a Service Interrupt

You can determine the reason for an SRQ by the following actions:

- Use a serial poll or the ***STB?** query to determine which summary bits are active.
- Read the corresponding Event register for each summary bit to determine which events caused the summary bit to be set. When an Event register is read, it is cleared. This also clears the corresponding summary bit.
- The interrupt will recur until the specific condition that caused each event is removed. If this is not possible, the event may be disabled by programming the corresponding bit of the status group Enable register or NTR|PTR filter. A faster way to prevent the interrupt is to disable the service request by programming the appropriate bit of the Service Request Enable register.

Servicing an Operation Status Mode Event

This example assumes you want a service request generated whenever the power supply switches to the CC (constant current) mode. From Figure 8-1, note that the required path is for a condition at bit 10 (CC) of the Operation Status register to set bit 6 (RQS) of the Status Byte register. The required register programming is shown in Table 8-5.

Table 8-5. Generating RQS from the CC Event

Register	Command	Comment
Operation PTR	STAT:OPER:PTR 1024	Allows a positive transition at the CC input (bit 10) to be latched into the Status Event register. ¹
Operation Enable	STAT:OPER:ENAB 1024	Allows the latched CC event to be summed into the OPER summary bit.
Service Request Enable	*SRE 128	Enables the OPER summary bit from the Status Byte register to generate RQS.
Operation Condition	STAT:OPER:EVEN?	When you service the request, read the event register to determine that bit 10 (CC) is set and to clear the register for the next event.

¹All bits of the PTR registers bits are set to 1 at power on or in response to **STAT:PRES**.

Adding More Operation Events

To add the CV (constant voltage) event to this example, it is only necessary to add the decimal values for bit 8 (value 64) to the programming commands of the Operation Status group. The commands to do this are:

STAT:OPER:PTR 1280;ENAB 1280

It is not necessary to change any other registers, since the programming for the operation summary bit (OPER) path has already been done.

Servicing Questionable Status Events

To add OC (overcurrent) and OT (overtemperature) events, program Questionable Status group bits 1 and 4.

STAT:QUES:PTR 18;ENAB 18

Next, you must program the Service Request Enable register to recognize both the questionable (QUES) and the operational (OPER) summary bits.

***SRE 136**

Now when there is a service request, read back both the operational and the questionable event registers.

STAT:OPER:EVEN?;QUES:EVEN?

Monitoring Both Phases of a Status Transition

You can monitor a status signal for both its positive and negative transitions. For example, to generate RQS when the power supply either enters the CC (constant current) condition or leaves that condition, program the Operational Status PTR/NTR filter as follows:

STAT:OPER:PTR 1024;NTR 1024
STAT:OPER:ENAB 1024;*SRE 128

The PTR filter will cause the OPER summary bit to set RQS when CC occurs. When the controller subsequently reads the event register (**STAT: OPER: EVEN?**), the register is cleared. When CC subsequently goes false, the NTR filter causes the OPER summary bit to again set RQS.

Specifications

Specifications are performance parameters warranted over the specified temperature range.

Supplemental Characteristics are not warranted but are descriptions of performance determined either by design or type testing.

Table A-1. Performance Specifications for Keysight E4356A

Parameter	Value
Output Ratings (@ 0 to 45°C)	Voltage: 0 - 80 V (0 to 26A) Current: 0 - 30 A (0 to 70 V)
Programming Accuracy (@ 25 °C ± 5 °C)	Voltage: 0.04% + 80 mV Current: 0.1 % + 25 mA
Ripple & Noise (from 20 Hz to 20 MHz with outputs ungrounded, or with either output terminal grounded)	Constant Voltage rms: 2 mV Constant Voltage p-p: 16 mV Constant Current rms: 25 mA (measured with 60 cm leads)
Readback Accuracy (from front panel or over GPIB with respect to actual output @ 25 °C ± 5 °C)	Voltage: 0.05% + 120 mV Current: 0.1 % + 35 mA
Load Regulation (change in output voltage or current for any load change within ratings)	Voltage: 0.002% + 3 mV Current: 0.005% + 2 mA
Line Regulation (change in output voltage or current for any line change within ratings)	Voltage: 0.002% + 3 mV Current: 0.005% + 2 mA
Transient Response Time (for the output voltage to recover to its previous level within 0.1% of the rated voltage or 20 mV, whichever is greater, following any step change in load current up to 50% of the rated current)	< 900 μs

Table A-2. Supplemental Characteristics for Keysight E4356A

Parameter	Value
Output Programming Range	Voltage: 81.9 V Current: 30.71 A Overvoltage Protection: 96 V
Typical Programming Resolution	Voltage: 20 mV Current: 7.5 mA Overvoltage Protection: 150 mV
Accuracy (@ 25 °C ± 5 °C)	Overvoltage Protection (OVP): 1.5 V Analog Programming (VP): ± 0.3% Analog Programming (IP): ± 7% Current Monitor (+IM): ± 7%
Drift Temperature Stability (following a 30-minute warmup, change in output over eight hours under constant line, load, and ambient temperature)	Voltage: 0.02% + 2.5 mV Current: 0.02% + 10 mA
Temperature Coefficients (change per °C after 30-minute warmup)	Voltage: 50 ppm + 1.6 mV Current: 75 ppm + 4 mA Voltage Readback ±Current Readback: 85 ppm + 5 mA Overvoltage Protection (OVP): 200 ppm + 18 mV Analog Programming (VP): 60 ppm + 0.7 mV Analog Programming (±IP): 275 ppm + 5 mA Current Monitor (+IM): 50 ppm + 0.6 mA
Typical Common Mode Noise Current (referenced to signal ground binding post)	rms 500 µA p-p 4 mA
Maximum Input VA and Power	with full load: 3800 VA; 2600 W, with no load: 100 W
AC Input Ranges (selectable via internal switching - see Appendix F)	200 Vac¹ nominal: 174-220 Vac 230 Vac nominal: 191-250 Vac Frequency: 47-63 Hz ¹ Below 185 Vac, derate output voltage linearly to 75.3 V
Output Terminal Isolation (maximum, from chassis ground)	±240 Vdc
Maximum AC Line Current Ratings	200 Vac nominal: 19 A rms (25 A fuse) 230 Vac nominal: 19 A rms (25 A fuse)
Maximum Reverse Bias Current:	With ac input power applied and the dc output reverse biased by an external power supply, the unit will continuously withstand without damage a current equal to its output current rating (see Table A-1).
Remote Sensing Capability	Voltage Drop Per Lead: Up to 1/2 of rated output voltage. Load Voltage: Subtract voltage drop in load leads from specified output voltage rating.
Load Regulation (ΔmV)	Degradation due to load lead drop in – output: $\Delta mV = V_{drop}(R_{sense-})/10$ Degradation due to load lead drop in + output: $\Delta mV = V_{drop}(R_{sense+})/10 + 2V_{drop}(V_{rating})/(V_{rating} + 10V)$ where R_{sense-} = resistance of – sense lead R_{sense+} = resistance of + sense lead

Table A-2. Supplemental Characteristics (continued)

Parameter	Value
Command Processing Time (Average time for output voltage to change after receipt of digital data when the unit is connected directly to the GPIB Bus):	20 ms
Output Voltage Rise Time/Fall Time (time for output to change from 90 % to 10% or from 10% to 90% of its total excursion with full resistive load)	100 ms/200 ms (excludes command processing time)
Full-load Programming Speed Up Time/Down Time (time for output to settle within 4 LSBs of the final value with full resistive load)	200 ms/475 ms (excludes command processing time)
No-load Programming Discharge Time (time for output to fall to 0.5V when programmed from full voltage to zero volts)	650 ms (excludes command processing time)
Monotonicity:	Output is monotonic over entire rated voltage, current, and temp. range.
Auto-Parallel Configuration:	Up to 3 units
Analog Programming (IP&VP) (signal source must be isolated; VP input is referenced to output signal common)	VP Input Signal: 0 to -4.15 V VP Input Impedance: 60 k Ω , nominal IP to -IP Differential Input: 0 to +6.75 V
Current Monitor Output (+IM) (signal range corresponds to from 0% to 100% of output current)	IM Output Signal: -0.25 to +8.08 V Output Impedance: 490 Ω
Nonvolatile Savable States	Memory Locations: 5 (0 through 4) Memory Write Cycles: 40,000, typical Factory Prestored State: Location 0
Digital Port Characteristics	Maximum ratings: 16.5 Vdc between terminals 1 & 2; 3&4; and from 1 or 2 to chassis.
FLT/INH Terminals 1 & 2	I_{ol} (low-level output current) 1.25 mA maximum V_{ol} (low-level output voltage) 0.5 V maximum
FLT/INH Terminals 3 & 4	V_{il} (low-level input voltage) 0.8 V maximum V_{ih} (high-level input voltage) 2.0 V minimum I_{il} (low-level input current) 1 mA tw (pulse width) 100 μ s, minimum td (time delay) 4 ms, typical
Digital OUT Port 0,1,2 - Open Collector:	I_{oh} (high-level output leakage @ 16.5V) 100 μ A (ports 0,1); 12.5 mA (port 2) I_{oh} (high-level output leakage @ 5.25V) 100 μ A (ports 0,1); 250 μ A (port 2) I_{ol} (low-level output sink current @ 0.5V) 4 mA I_{ol} (low-level output sink current @ 1V) 250 mA
Digital IN Port 2 - Internal 4.64 k Pullup:	I_{il} (low-level input current @ 0.4 V) 1.25 mA I_{ih} (high-level input current @ 5.25 V) 250 μ A V_{il} (low-level input voltage) 0.8 V maximum V_{ih} (high-level input voltage) 2.0 V minimum
GPIB Interface Capabilities	Languages: SCPI (default); Compatibility Interface: AH1, C0, DC1, DT1, E1, LE4, PP0, RL1, SH1, SR1, TE6
Serial Link Capabilities (multiple units sharing one GPIB primary address)	Maximum number of units: 16 Maximum number of linked units: 15 Maximum total chain cable length: 30 m (100 ft)
Recommended Calibration Interval:	1 year

Table A-2. Supplemental Characteristics (continued)

Safety Compliance	Complies with: CSA 22.2 No.231, IEC 348 Designed to comply with: UL 1244
RFI Suppression	Complies with: CISPR-II, Group 1, Class B
Dimensions	Width: 425.5 mm (16.75 in) Height (with removable feet): 145.1 mm (5.71 in) Depth (with safety cover): 640 mm (25.2 in)
Weight	Net: 27.7 kg (61 lb) Shipping: 31.4 kg (69 lb)

Output Impedance Curves (Typical):

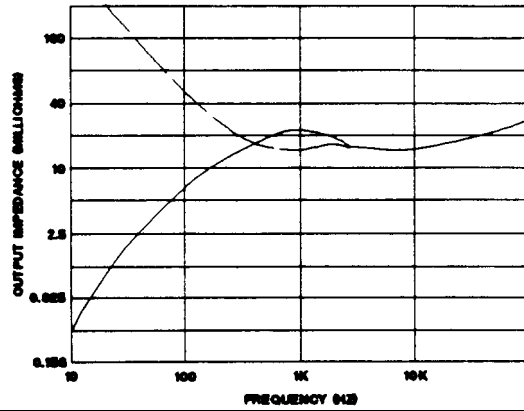

Calibration

Introduction

The power supply may be calibrated either from the front panel or from a controller over the GPIB. The procedures given here apply to all models.

Important These instructions do not include verification procedures. If you need to perform verification as a prerequisite to or as part of your calibration procedure, see “Appendix B - Verification”.

Equipment Required

The equipment listed in Table B-1, or equivalent, is required for calibration.

Table B-1. Equipment Required For Calibration

Equipment	Characteristics	Recommended Model
Voltmeter	Dc accuracy 0.005%, 6 digits	Keysight 3456A or 3458A
Shunt resistor	100 A, 0.001 Ω , 0.04%, 100 W	Guildline 9230/100
GPIB Controller	For Calibration over the GPIB	HP Vectra (or IBM compatible) with GPIB Interface, or Keysight BASIC series

General Procedure

WARNING

Because the power supply output must be enabled during calibration, voltages or currents hazardous to personnel and/or damaging to equipment can appear at the output terminals.

Parameters Calibrated

The following parameters may be calibrated:

- Output voltage.
- Output voltage readback.
- Overvoltage protection (OVP).
- Output current.
- Output current readback.

You do not have to do a complete calibration each time. If appropriate, you may calibrate only the voltage or current and proceed to "Saving the Calibration Constants".

Test Setup

Figure B-1 shows the test setups required for voltage and current calibration for each power supply series.

Front Panel Calibration

Eight shifted keys and the Entry keypad are used for calibration functions (see Chapter 5 for explanations of shifted keys and the Entry keypad). The following procedures assume you understand how to operate front panel keys.

Entering the Calibration Values

Follow the steps in Table B-2 for entering calibration values.

Saving the Calibration Constants



Storing calibration constants overwrites the existing ones in nonvolatile memory. If you are not absolutely sure you want to permanently store the new constants, omit this step. The power supply calibration will then remain unchanged.

To replace any existing calibration constants with ones you have just entered, press **Cal Save**. **CAL SAVED** then appears on the display.

Disabling the Calibration Mode

To disable the calibration mode, press **Cal Disable**. The display will return to meter mode with the **Cal** annunciator off.

Changing the Calibration Password

The factory default password is the model number of your unit, such as E4356A. You can change the calibration password only when the power supply is in the calibration mode (which requires you to enter the existing password). Proceed as follows:

1. Press **Pass**.
2. Enter the new password from the keypad. (You can use up to six integers and an optional decimal point.) If you want **Cal Enable** to operate without requiring any password, change the password to 0 (zero).
3. **AGAIN** will appear on the display. Enter the password a second time.
4. When **OK** is displayed, the new password has been accepted.

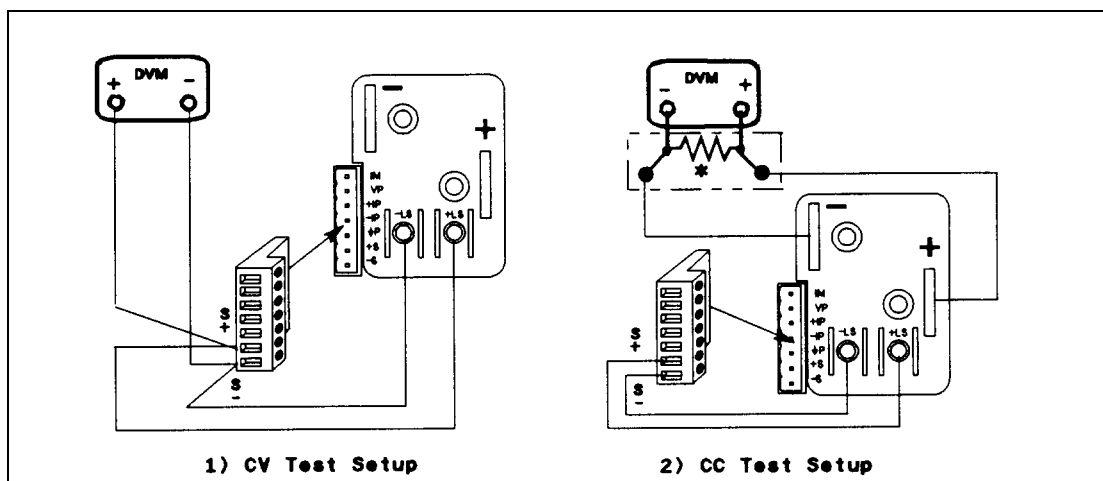

Figure B-1. Calibration Test Setup

Table B-2. Typical Front Panel Calibration Procedure

Action	Display Response
<p style="text-align: center;">Enabling the Calibration Mode</p> <p>1. Begin calibration by pressing Cal Enable .</p> <p>2. Enter calibration password from Entry keypad. If password is correct the Cal annunciator will come on. If password is incorrect, an error occurs².</p> <p>Note: The initial (factory-default) password is the model number of the power supply, but it can be changed (see "Changing the Password").</p>	<p>PASWD¹</p> <p>PASSWD ERROR</p>
<p style="text-align: center;">Entering Voltage Calibration Values</p> <p>1. Make certain the DVM is the only load on the power supply.</p> <p>2. Select the first calibration point by pressing Vcal . If the power supply is not in CV mode, an error occurs³</p> <p>3. Read the DVM and use the Entry keypad to enter the first voltage value.</p> <p>4. Select the second calibration point by pressing Vcal again.</p> <p>5. Read the DVM and use the Entry keypad to enter the second voltage value.</p> <p>Note: If one of the entered values is not within acceptable range, an error occurs. <i>The power supply is now holding the new voltage calibration constants in RAM.</i></p>	<p>(Meter mode) VRDG1 WRONG MODE (Meter mode) VRDG2 (Meter mode) CAL ERROR</p>
<p style="text-align: center;">Calibrating the OVP Trip Point</p> <p>1. Make certain the voltage has been calibrated and there is no load on the power supply.</p> <p>2. Select OVP calibration by pressing OVCAL .</p> <p>3. Wait for the power supply to compute the OVP calibration constant. If the unit goes unregulated or into CC mode during OVP calibration, an error occurs. If the computed constant is out of acceptable range, an error occurs. <i>The power supply is now holding the new OVP calibration constant in RAM.</i></p>	<p>(Meter mode) OVPCAL CAL COMPLETE NOT CV MODE DOES NOT CAL</p>
<p style="text-align: center;">Entering Current Calibration Values</p> <p>1. Make certain appropriate shunt resistor (see Table A-1) is the only load on the power supply.</p> <p>2. Select the first calibration point by pressing Ical . If the power supply is not in CC mode, an error occurs.⁴</p> <p>3. Wait for DVM reading to stabilize. Then read DVM and compute the first current value (DVM reading ÷ shunt resistance).</p> <p>4. Use Entry keypad to enter the first current value.</p> <p>5. Select second calibration point by pressing Ical again.</p> <p>6. Wait for DVM reading to stabilize. Then read DVM and compute the second current value (DVM reading ÷ shunt resistance).</p> <p>7. Use Entry keypad to enter the second current value. Note: If the entered value is not within acceptable range, an error occurs. <i>Wait for the power supply to compute the new current calibration constants, which will be stored in RAM.</i></p>	<p>(Meter mode) IRDG1 WRONG MODE (Meter mode) (Meter mode) IRDG2 (Meter mode) (Meter mode) CAL ERROR CAL COMPLETE</p>

Notes:

¹ If **CAL DENIED** appears, then an internal jumper has been set to prevent the calibration from being changed. (See the *Service Manual*.)

² If the active password is lost, the calibration function can be recovered by moving an internal jumper that defeats password protection. However, this also will change all calibration constants to their factory-default values. (For more information, see the *Service Manual*.)

³ Program the output current to 10% of its rated output

⁴ Program the output voltage to 10% of its rated output

Recovering From Calibration Problems

You can encounter serious calibration problems if you cannot determine a calibration password that has been changed or the power supply is severely out of calibration. There are jumpers inside the power supply that permit the calibration password to be defeated and allow the original factory calibration constants to be restored. These jumpers are explained in the *Service Manual*.

Calibration Error Messages

Error messages that can occur during calibration are shown in Table A-3.

Table B-3. GPIB Calibration Error Messages

Error No.	Meaning	Error No.	Meaning
1	CAL jumper prevents calibration ¹	6	Wrong CAL command sequence
2	CAL password is incorrect	7	Incorrect state (CV/CC) for this command
3	CAL mode is not enabled		
4	Incorrect computed readback constants		
5	Incorrect computed programming constants		

¹ This is a hardware disable. See the power supply *Service Manual*.

Calibration Over The GPIB

You can calibrate the power supply by using SCPI commands within your controller programming statements. Be sure you are familiar with calibration from the front panel before you calibrate from a controller. The SCPI calibration commands are related to the front panel calibration controls as follows:

Front Panel Command	Corresponding SCPI Command	Front Panel Command	Corresponding SCPI Command
Cal Enable	CAL:STAT {ON 1},<password>	Ical	CAL:CURR:LEV {MIN MAX} CAL:CURR[:DATA] <Nrf>
Cal Disable	CAL:STAT {OFF 0}	Cal lmon	CAL:CURR:MON<newline> CAL:CURR:DATA <NRF>
Pass	CAL:PASS <NRF>	Cal Save	CAL:SAVE
Vcal	CAL:VOLT:LEV {MIN MAX} CAL:VOLT[:DATA] <Nrf>		
OVCal	CAL:VOLT:PROT		

Calibration Example

A sample calibration program is given at the end of this appendix. If your system is Keysight BASIC, you can use the program with very little modification. Otherwise, use it as a guide for writing your own program.

Calibration Language Dictionary

The calibration commands are listed in alphabetical order. The format for each command follows that shown in Chapter 7. Calibration error messages that can occur during GPIB calibration are shown in Table B-3.

CAL:CURR

This command is used to calibrate the output current. The command enters current value that you obtain from an external meter. (If you are entering the current value, allow time for the DVM to stabilize.) You must first select a calibration level (**CAL:CURR:LEV**) for the value being entered. Two successive values (one for each end of the calibration range) must be selected and entered. The power supply then computes new current calibration constants. These constants are **not** stored in nonvolatile memory until saved with the **CAL:SAVE** command.

Command Syntax	CALibrate:CURRent[:DATA] <NRf>
Parameters	(See applicable Output Ratings specification in "Chapter 1- General Information")
Default Suffix	A
Examples	CAL: CURR 32 . 33 A CAL: CURR: DATA 5 . 00
Query Syntax	(None)
Related Commands	CAL:SAVE CAL:STAT

CAL:CURR:LEV

This command sets the power supply to a calibration point that is then entered with **CAL:CURR[:DATA]**. During calibration, two points must be entered and the low-end point (MIN) must be selected and entered first.

Command Syntax	CALibrate:CURRent:LEVel {MIN MAX}
Parameters	{<CRD> MINimum MAXimum}
Examples	CAL: CURR: LEV MIN CAL: CURR: LEV MAX
Query Syntax	(None)
Related Commands	CAL:CURR[:DATA] CAL:STAT

CAL:PASS

This command enters a new calibration password. The command is active only when the power supply is already in the calibration mode. Unless it is changed subsequently to shipment, the password is the power supply's four-digit model number. If the password is set to 0, password protection is removed and **CAL:STAT ON** is unrestricted. A new password is automatically stored in nonvolatile memory and does not have to be stored with the **CAL:SAVE** command.

Command Syntax	CALibrate:PASScode <NRf>
Parameters	<NRf>
Examples	CAL:PASS 4356 CAL:PASS 09.1993
Query Syntax	(None)
Related Commands	CAL:STAT

CAL:SAVE

This command saves any new calibration constants (after a current or voltage calibration procedure has been completed) in nonvolatile memory.

Command Syntax:	CALibrate:SAVE
Parameters	(None)
Examples	CAL: SAVE
Query Syntax	(None)
Related Commands	CAL:CURR CAL:VOLT CAL:STAT

CAL:STAT

This command enables and disables the calibration mode. The calibration mode must be enabled before the power supply will accept any other calibration commands. The first parameter specifies the enabled or disabled state. The second parameter is the password. It is required if the calibration mode is being enabled and the existing password is not 0. If the second parameter is not entered or is incorrect, an error is generated and the calibration mode remains disabled. The query statement returns only the state, not the password. Note that whenever the calibration mode is changed from enabled to disabled, any new calibration constants are lost unless they have been stored with CAL:SAVE.

Command Syntax:	CALibrate:STATe <bool> [,<NRf>]
Parameters	{0 OFF} {1 ON} [,<NRf>]
*RST Value	OFF
Examples	CAL:STAT 1,4356 CAL:STAT OFF
Query Syntax	CALibrate:STATe?
Returned Parameters	{0 1 }
Related Commands	CAL:PASS CAL:SAVE

CAL:VOLT

This command is used to calibrate the output voltage. The command enters voltage value that you obtain from an external meter. (If you are entering the voltage value, allow time for the DVM to stabilize.) You must first select a calibration level (CAL:VOLT:LEV) for the value being entered. Two successive values (one for each end of the calibration range) must be selected and entered. The power supply then computes new voltage calibration constants. These constants are not stored in nonvolatile memory until saved with the CAL:SAVE command.

Command Syntax	CALibrate:VOLTage[:DATA] <NRf>
Parameters	(See applicable Output Ratings in "Chapter 1- General Information")
Default Suffix	A
Examples	CAL: VOLT 322 . 5 MV CAL: VOLT: DATA 3 . 225
Query Syntax	(None)
Related Commands	CAL:SAVE CAL:STAT

CAL:VOLT:LEV

This command sets the power supply to a calibration point that is then entered with CAL:VOLT[:DATA]. During calibration, two points must be entered and the low-end point (MIN) must be selected and entered first.

Command Syntax	CALibrate:VOLTage:DATA {MIN MAX}
Parameters	{ <CRD> MINimum MAXimum }
Examples	CAL: VOLT: LEV MIN CAL: VOLT: LEV MAX
Query Syntax	(None)
Related Commands	CAL:VOLT[:DATA] CAL:STAT

CAL:VOLT:PROT

This command calibrates the overvoltage protection (OV) circuit. It takes several seconds to complete. The *output voltage must be calibrated* before this procedure is performed. Also, the power supply output must be enabled and operating in the constant voltage (CV) mode. If present, the optional relay accessory must either be disconnected or set to the off (open) state. The power supply automatically performs the calibration and stores the new OV constant in nonvolatile memory.

Command Syntax:	CALibrate:VOLTage:PROTection
Parameters	(None)
Example	CAL: VOLT: PROT
Query Syntax	(None)
Related Commands	CAL:STAT

BASIC Calibration Program

The following program can be run on any controller operating under Keysight BASIC. The assumed power supply address is 5 and calibration password is 4356. If required, change these parameters in the appropriate statements.

```
10 ! Keysight BASIC Calibration Program
20 !
30 DIM Resp$ [255],Err_msg$[255]
40 !
50 Volt_cal: ! Voltage DAC calibration
60 Err_found=0
70 PRINT TABXY(5,10),"CONNECT INSTRUMENTS AS SHOWN IN FIG. A-1(1). Then Press Continue"
80 PAUSE
90 CLEAR SCREEN
100 !
110 ! Assign power supply GPIB address
120 !
130 ASSIGN @Ps TO 705
140 !
150 ! Initialize power supply
160 !
170 OUTPUT @Ps;"*RST;OUTPUT ON"
180 !
190 ! Password is optional - only required if set to non-zero value
200 ! Default password is the four-digit model number
210 !
220 ! LINE 240 PASSWORD MUST BE EDITED FOR MODEL OTHER THAN 6680
230 !
240 OUTPUT @Ps;"CAL:STATE ON, 4356"
250 1
260 OUTPUT @Ps;"CAL:VOLTAGE:LEVEL MIN"
270 INPUT "ENTER VOLTAGE MEASUREMENT FROM EXTERNAL VOLTMETER",Volt_read
280 OUTPUT @Ps;"CAL:VOLTAGE ";Volt_read
290 OUTPUT @Ps;"CAL:VOLTAGE:LEVEL MAX"
300 INPUT "ENTER VOLTAGE MEASUREMENT FROM EXTERNAL VOLTMETER",Volt_read
310 OUTPUT @Ps;"CAL:VOLTAGE ";Volt_read
320 !
330 ! Calibrate overvoltage protection circuit
340 !
350 OUTPUT @Ps;"CAL:VOLTAGE:PROTECTION"
360 !
370 GOSUB Save_cal
380 IF Err_found THEN
390 INPUT "ERRORS have occurred, REPEAT VOLTAGE CALIBRATION ( Y OR N )?",Resp$
400 IF TRIM$(UPC$(Resp$[1,1] ))="Y" THEN GOTO Volt_cal
410 END IF
420 IF Err_found THEN
430 PRINT "VOLTAGE CALIBRATION NOT SAVED"
440 ELSE
450 PRINT "VOLTAGE CALIBRATION COMPLETE"
460 END IF
470 !
```

Figure B-2. BASIC Calibration Program (continued)

```
480 Current_cal: ! Imon DAC and Current DAC calibration
490 Err_found=0
500 PRINT TABXY(5,10),"CONNECT INSTRUMENTS AS SHOWN IN FIG. A-1(2). Then Press Continue"
510 PAUSE
520 CLEAR SCREEN
540 Password is optional - only required if set to non-zero value
550 Default password is four-digit model number
560 !
570 ! LINE 590 PASSWORD MUST BE EDITED FOR MODEL OTHER THAN E4356A
580 !
590 OUTPUT @Ps;"CAL:STATE ON, 4356"
600 OUTPUT @Ps;"VOLT:LEV 2"
610 ! Refer to Table A-1 for correct shunt value for model being calibrated
620 !
630 INPUT "ENTER VALUE OF CURRENT SHUNT BEING USED",Shunt_val
680 OUTPUT @Ps;"CAL:CURRENT:LEVEL MIN"
690 INPUT "ENTER VOLTAGE MEASUREMENT FROM EXTERNAL VOLTMETER",Volt_read
700 Current=Volt_read/Shunt_val
710 OUTPUT @Ps;"CAL:CURRENT ";Current
720 OUTPUT @Ps;"CAL:CURRENT:LEVEL MAX"
730 INPUT "ENTER VOLTAGE MEASUREMENT FROM EXTERNAL VOLTMETER",Volt_read
740 Current=Volt_read/Shunt_val
750 OUTPUT @Ps;"CAL:CURRENT ";Current
760 GOSUB Save_cal
770 IF Err_found THEN
780     INPUT "ERRORS have occurred, REPEAT CURRENT CALIBRATION ( Y OR N )?",Resp$
790     IF TRIM$(UPC$(Resp$[1,1]))="Y" THEN GOTO Volt_cal
800 END IF
810 IF Err_found THEN
820     PRINT "CURRENT CALIBRATION NOT SAVED"
830 ELSE
840     PRINT "CURRENT CALIBRATION COMPLETE"
850 END IF
860 STOP
870 Save_cal: ! SAVE CALIBRATION
880 REPEAT
890     OUTPUT @Ps;"SYSTEM:ERROR?"
900     ENTER @Ps;Err_num,Err_msg$
910     IF Err_num<>0 THEN
920         PRINT "ERROR: ";Err_msg$
930         Err_found=1
940     END IF
950 UNTIL Err_num=0
960 IF NOT Err_found THEN
970     INPUT "SAVE CALIBRATION CONSTANTS ( Y OR N )?",Resp$
980     IF TRIM$(UPC$(Resp$[1,1]))="Y" THEN
990         OUTPUT @Ps;"CAL:SAVE"
1000    END IF
1010 END IF
1020 OUTPUT @Ps;"CAL:STATE OFF"
1030 RETURN
1040 END
```

Verification

Introduction

This appendix provides operation verification test procedures. The tests do not check all the operating parameters, but verify that the power supply is performing properly. The required test equipment and acceptable test results are specified in tables at the end of this appendix.

Note Performance Tests, which check all the specifications of the power supply, are given in the Service Manual.

Test Equipment Required

List of Equipment

The following equipment is required to perform the tests:

Table C-1. Equipment Required for Verification Tests

Equipment	Characteristics	Recommended Model
Digital Voltmeter	Resolution: 10 nV @ 1 V Readout: 8 1/2 digits Accuracy: 20 ppm	Keysight 3458A
Current Monitor Resistor	100 A, 0.001 Ω, 0.04%, 100 W	Guildline 9230/100

Current Monitoring Resistor

The 4-terminal current-monitoring resistor listed in Table B-1 is required to eliminate output current measurement error caused by voltage drops in leads and connections. The specified resistors have special current-monitoring terminals inside the load connection terminals. Connect the digital voltmeter directly to these current-monitoring terminals.

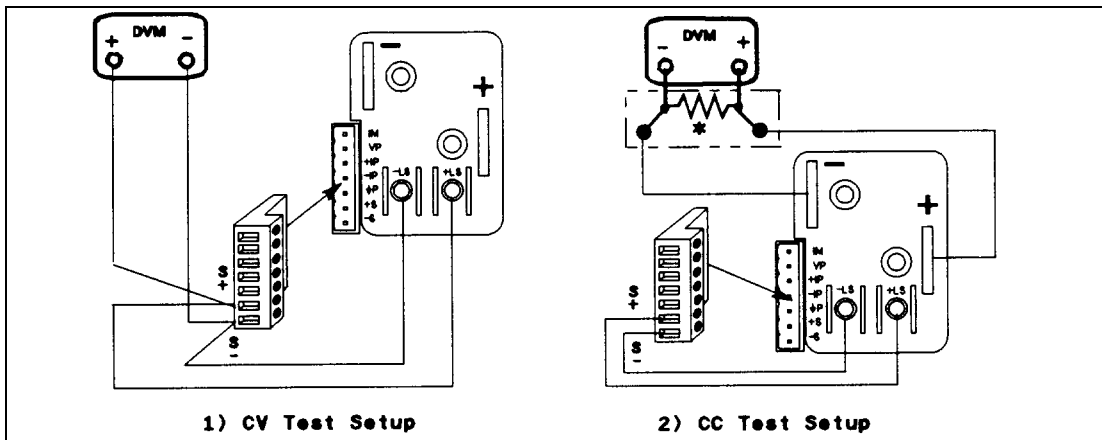

Figure C-1. Verification Test Setup

Performing The Tests

General Measurement Techniques

Figure C-1 shows the setup for the tests. Be certain to use load leads of sufficient wire gauge to carry the output current (see Table 8-1). To avoid noise pickup, use coaxial cable or shielded pairs for the test leads.

Programming the Power supply

Appendix A lists the programming voltage and current ranges. Enter the appropriate values from the front panel. The programming procedures assume you know how to operate the power supply from the front panel (see "Chapter 5 - Front Panel Operation").

Order of Tests

Perform the following tests for operation verification. Test 1 must be done first, followed by Tests 2 and 3 in any order.

- 1 Turn-on Checkout
- 2 Voltage Programming and Readback Accuracy
- 3 Current Programming and Readback Accuracy

Turn-on Checkout

Perform the Turn-on Checkout as directed in "Chapter 3 - Turn-on Checkout".

Note The power supply must pass turn-on selftest before you can proceed with these tests.

Voltage Programming and Readback Accuracy

This test verifies that the voltage programming, GPIB readback, and front panel display functions are within specifications. Figure C-1(1) shows the setup for the tests. Measure the dc output voltage directly at the sense connections of the output terminals or bus bars. Connect the output as shown.

Table C-2. Voltage Programming and Readback Accuracy Tests

	Action	Normal Result
1	Turn off the power supply and connect a DVM across the sense terminals (see Figure C-1(1)).	
2	Turn on the power supply with no load and program the output for 0 volts and maximum programmable current.	CV annunciator on. Output current near 0.
3	Record voltage readings at DVM and on front panel display. (Subtract or add the specified readback limit to the actual output values).	Readings within Low Voltage limits (see applicable test table).
4	Program voltage to full scale.	
5	Record voltage readings of DVM and on front panel display. (Subtract or add the specified readback limit to the actual output values)	Readings within High Voltage limits (see applicable test table).

Current Programming and Readback Accuracy

This test verifies that the current programming and readback are within specification. Connect the appropriate current monitoring resistor (see Table C-1) as shown in Figure C-1(2). The accuracy of the resistor must be as specified in the table.

Table C-3. Current Programming and Readback Accuracy Test

	Action	Normal Result
1	Turn off the power supply and connect the current monitoring resistor as shown in Figure C-1(2). Be certain to use wire of sufficient size to carry the maximum rated current of the unit (see Table 7-1 in Chapter 7).	
2	Connect a DVM across the resistor at the monitoring terminals.	
3	Turn on the power supply and program the output for 5V, 0A.	
4	Disable the output (<input type="button" value="Output Off"/>)	
5	Enable the output (<input type="button" value="Output On"/> or OUTP ON).	
6	Observe the DVM voltage reading. Divide this by the resistance of the current monitor resistor. Record the result as the Low Current value in applicable test table.	Value within Low Current limits (see applicable test table).
7	Record the front panel display readback	Value within specified readback limits (see applicable test table).
8	Program output current to full scale.	
9	Repeat Steps 6 and 7.	Both current readings within specified High Current and readback limits (see applicable test table).
10	Disable the output (<input type="button" value="Output Off"/>).	
11	Remove the short from across the load.	

Table C-4. Operation Verification Test Parameters

Test Description	Minimum Spec	Results *	Maximum Spec	Measurement Uncertainty
Voltage Programming and Readback				
Low Voltage (0 V) V_{out}	-80 mV	_____ mV	+ 80 mV	2.2 μ V
Front Panel Display Readback	V_{out} -120 mV	_____ mV	V_{out} +120 mV	2.2 μ V
High Voltage (80 V) V_{out}	79.888 V	_____ V	80.112 V	1 mV
Front Panel Display Readback	V_{out} -160 mV	_____ mV	V_{out} +160 mV	1 mV
Current Programming and Readback				
Low Current (0 A) I_{out}	-25 mA	_____ mA	+25 mA	21 μ A
Front Panel Display Readback	I_{out} -35 mA	_____ mA	I_{out} +35 mA	21 μ A
High Current (30 A) I_{out}	29.945 A	_____ A	30.055 A	15 mA
Front Panel Display Readback	I_{out} -65 mA	_____ mA	I_{out} +65 mA	15 mA
* Enter your test results in this column.				

Error Messages

Power supply Hardware Error Messages

Front panel error messages resulting from selftest errors or runtime failures are described in “Chapter 3 - Turn-On Checkout”.

Calibration Error Messages

Front panel error messages resulting from calibration errors are described in Appendix B.

System Error Messages

System error messages are obtained remotely with the **SYST:ERR?** query or by pressing the front panel **Error** key. The error number is the value placed in the error queue. SYST:ERR? returns the error number into a variable and combines the number and the error message into a string. Table D-1 lists the system errors that are associated with SCPI syntax errors and with interface problems. Information inside the brackets is not part of the standard error message, but is included for clarification. When system errors occur, the Standard Event Status register (see "Chapter 8 - Status Reporting") records them as follows:

Standard Event Status Register Error Bits

Bit Set	Error Code	Error Type	Bit Set	Error Code	Error Type
5	-100 thru -199	Command	3	-300 thru -399	Device-dependent
4	-200 thru -299	Execution	2	-400 thru -499	Query

Table D-1. Summary of System Error Messages

Error Number	Error String [Description/Explanation/Examples]
-100	Command error [generic command error]
-101	Invalid character
-102	Syntax error [unrecognized command or data type]
-103	Invalid separator [illegal character encountered in place of separator]
-104	Data type error [e.g., “numeric or string expected, got block date”]
-105	GET not allowed [<GET> inside a program message]
-108	Parameter not allowed [too many parameters]
-109	Missing parameter [too few parameters]
-112	Program mnemonic too long [maximum 12 characters]
-113	Undefined header [syntactical correct but not defined for this device]
-121	Invalid character in number [e.g. alpha in decimal data, etc.]
-123	Exponent too large [numeric overflow; exponent magnitude >32000]
-124	Too many digits [number too long; more than 255 digits received]
-128	Numeric data not allowed [numeric data not accepted where positioned]
-131	Invalid suffix [unrecognized suffix, or suffix not appropriate]
-138	Suffix not allowed [numeric element does not allow suffixes]

Table D-1. Summary of System Error Messages (continued)

Error Number	Error String [Description/Explanation/Examples]
-141	Invalid character data [bad character, or unrecognized]
-144	Character data too long [maximum length is 12 characters]
-148	Character data not allowed [character data not accepted where positioned]
-150	String data error [generic string error]
-151	Invalid string data [e.g., END received before close quote]
-158	String data not allowed [string data not accepted where positioned]
-160	Block data error [generic data block error]
-161	Invalid block data [e.g., END received before length satisfied]
-168	Block data not allowed [block data not accepted where positioned]
-220	Parameter error
-221	Settings conflict [uncoupled parameters]
-222	Data out of range [e.g., outside the range of this device]
-223	Too much data [out of memory; block, string, or expression too long]
-240	Hardware error [device-dependent]
-241	Hardware missing [device-dependent]
-310	System error [device-dependent]
-313	Calibration memory lost [out of calibration due to memory failure]
-330	Self-test failed [more specific data after “;”]
-350	Queue overflow [errors lost due to too many errors in queue]
-400	Query error [generic query error]
-410	Query INTERRUPTED [query followed by DAB or GET before response complete]
-420	Query UNTERMINATED [addressed to talk, incomplete programming message received]
-430	Query DEADLOCKED [too many queries in command string]
-440	Query UNTERMINATED [query received after query for indefinite response]

Line Voltage Conversion

WARNING

SHOCK HAZARD. Hazardous voltage can remain inside the power supply even after it has been turned off. This procedure should only be done by qualified electronics service personnel.

Line voltage conversion is accomplished by setting a line voltage select switch. Proceed as follows:

1. Turn off the ac power and disconnect the power cord from the power source.
2. Remove the four screws securing the carrying straps and dustcover.
3. Spread the bottom rear of the dustcover and pull it back to disengage it from the front panel.
4. Slide the dustcover back far enough to expose the line select switch (see Figure E-1).
5. Observe the input rail LED under the RFI shield. **If the LED is on, there is still hazardous voltage inside the unit.** Wait until the LED goes out (this may take several minutes) before proceeding.
6. Connect a dc voltmeter across test points TP1 and TP2. (It may be necessary to remove the RFI shield in order to reach these test points. The shield is secured by four screws on each side.) When the voltmeter indicates 60 volts or less, it is safe to work inside the power supply.
7. Locate the line selector switch and slide it to the desired position.
8. If you removed it in step 6, be sure to replace the RFI shield.
9. Replace the dustcover.

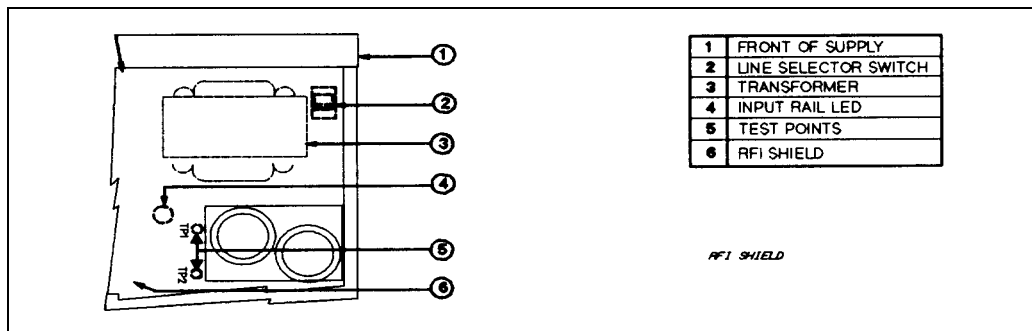

Figure E-1. Line Select Switch

Digital Port Functions

Digital Connector

A 4-pin connector and a quick-disconnect mating plug are provided for digital input and output signals (see Figure F-1 for wiring connections, and Table A-2 for electrical characteristics). This digital port can be configured to provide either Fault/Inhibit or Digital I/O functions.

Note Consistent with good engineering practice, twist and shield all signal wires to and from the digital connector.

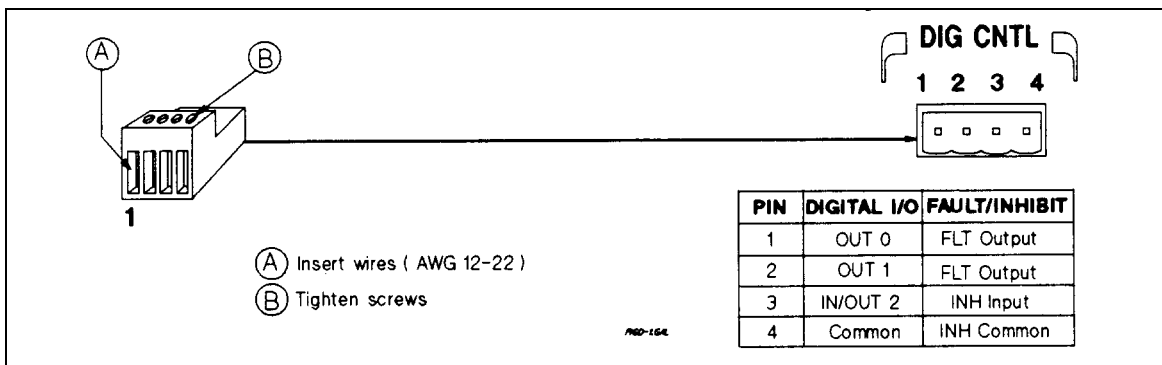

Figure F-1. Digital Port Connector

Fault/Inhibit Operation

As shipped from the factory, the digital port is configured to provide a fault indicator (FLT) output and a remote (INH) input. Unplug the mating plug to make the connections. After you have finished making all connections, plug the wired plug back into the connector.

FLT Output (pins 1 and 2) Used to indicate that a fault has occurred in power supply. Pins 1 and 2 are the open collector output of an optocoupler, with pin 1 the collector and pin 2 the emitter. When a fault has occurred, pin 1 is driven low with respect to pin 2 (negative-true).

INH Input (pin 3) Used to shut down the power supply output. Pin 3 is a high impedance input. The unit shuts down when this input is driven low (negative-true). This can be done by shorting pin 3 to pin 4.

INH Common (pin 4) Provides the common connection for the INH input.

Three examples are provided to show how to use the FLT/INH circuits of your power supply. Use twisted wire connections to reduce or prevent EM in all cases. If shielded wire is used, connect only one end of the shield to the chassis signal ground binding post to prevent ground loops.

In Figure F-2, the INH input is connected to a switch that shorts pin 3 to pin 4 whenever it is necessary to externally disable the output of the unit. This will activate the remote inhibit (RI) fault protection circuit, causing the front panel **Prot** annunciator to come on. It also sets the RI event bit in the unit's Questionable Status Event register (see "Chapter 8 - Status Reporting"). To re-enable the unit after it has been disabled by the INH input, first open the connection between pins 3 and 4. Then clear the protection circuit either from the front panel (see "Chapter 5 - Front Panel Operation" in this guide) or over the GPIB (see the Programming Guide).

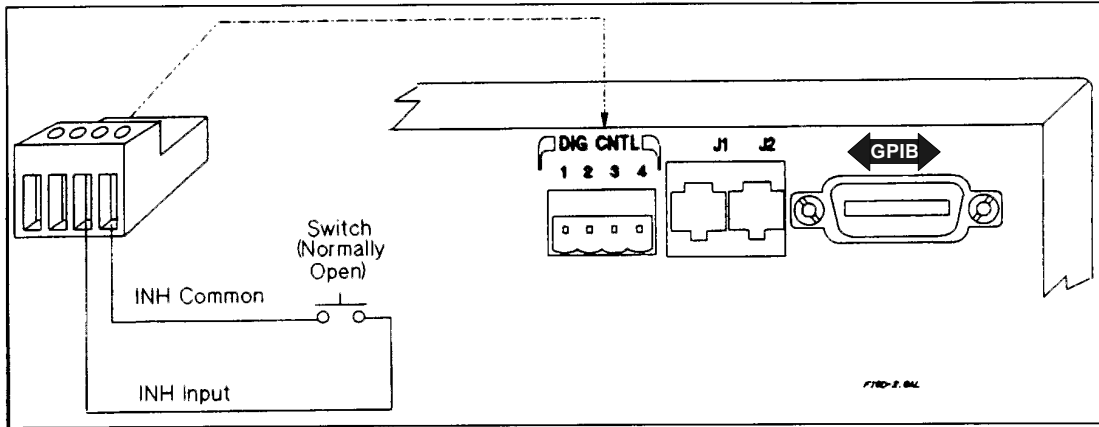

Figure F-2. Example of Inhibit Input

In Figure F-3A, the FLT output is connected to a relay driver circuit that energizes a relay whenever a fault condition occurs in the power supply. The relay can be used to physically disconnect the output of the power supply from the load. The FLT output is generated by the logical ORing of the power supply's Operation, Questionable, and Event status summary bits (see "Chapter 8 - Status Reporting" in the Programming Guide). You can cause one or more events to activate the FLT output by enabling the appropriate events in these status registers. The fault condition is cleared by first removing the cause of the fault and then reading the appropriate status event register(s).

In Figure F-3B, the FLT output of one unit is connected to the INH input of another unit. Although only two supplies are shown, it is possible to chain other supplies with this arrangement. A fault condition in any one of the power supplies will disable all of them without intervention either by the controller or external circuitry. The controller can be made aware of the fault via a service request (SRQ) generated by the Questionable Status summary bit (see "Chapter 8 - Status Reporting" in the Programming Guide).

Note The INH input cannot be used to disable outputs set from the external voltage programming port.

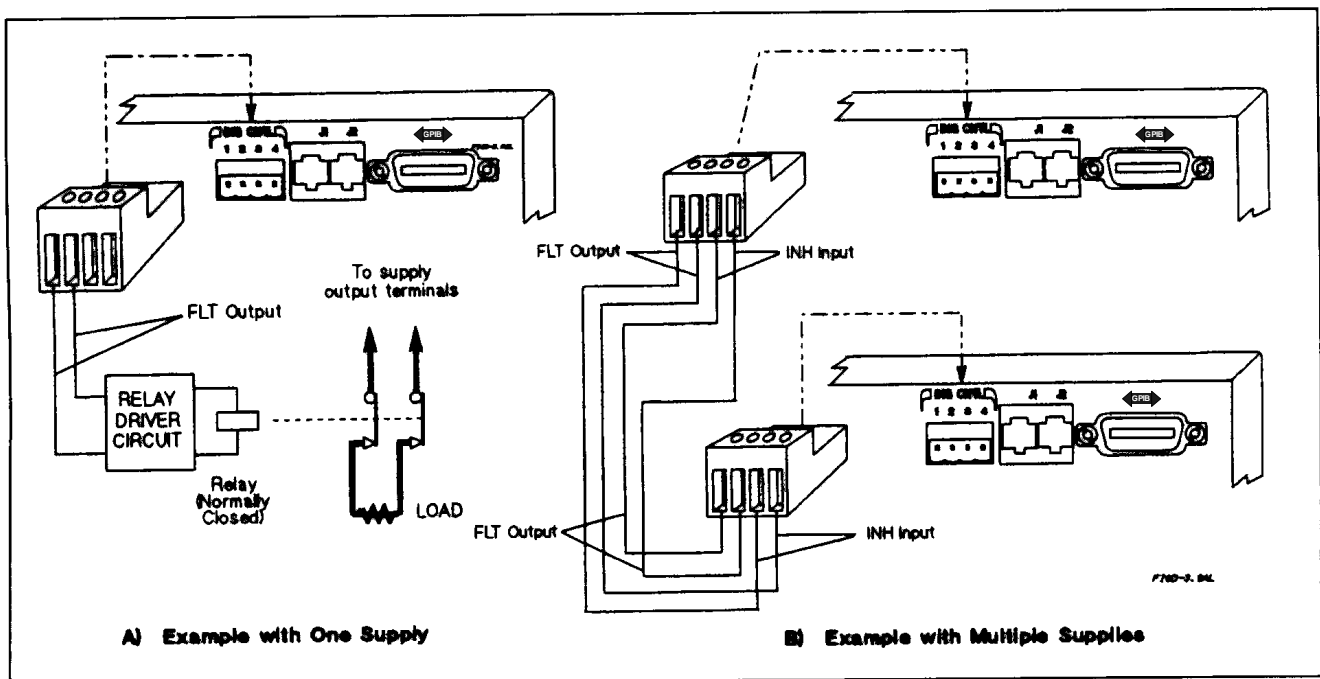

Figure F-3. Examples of FLT Outputs

Changing The Port Configuration

As shipped from the factory, the digital port is configured for FLT/INH operation. You can change the configuration of the port to operate as a general-purpose digital input/output port to control your custom circuitry as shown in Figure F-4. To change the port configuration, you must move a jumper on the GPIB board.

WARNING

Shock Hazard. Hazardous voltage can remain inside the power supply even after it has been turned off. This procedure should only be done by qualified electronics service personnel.

Proceed as follows:

1. Turn off the power supply and disconnect the power cord from the power source.
2. Remove the four screws that secure the two carrying straps and outer cover.
3. Spread the bottom rear of the cover and pull it back to disengage it from the front panel.
4. Slide the outer cover back to expose the top of the GPIB board.
5. Refer to Figure F-4 and use needle-nose pliers to move the jumper to the Digital I/O position.
6. Replace the outer cover, and secure the carrying straps.
7. Make the necessary wire connections to the digital connector.

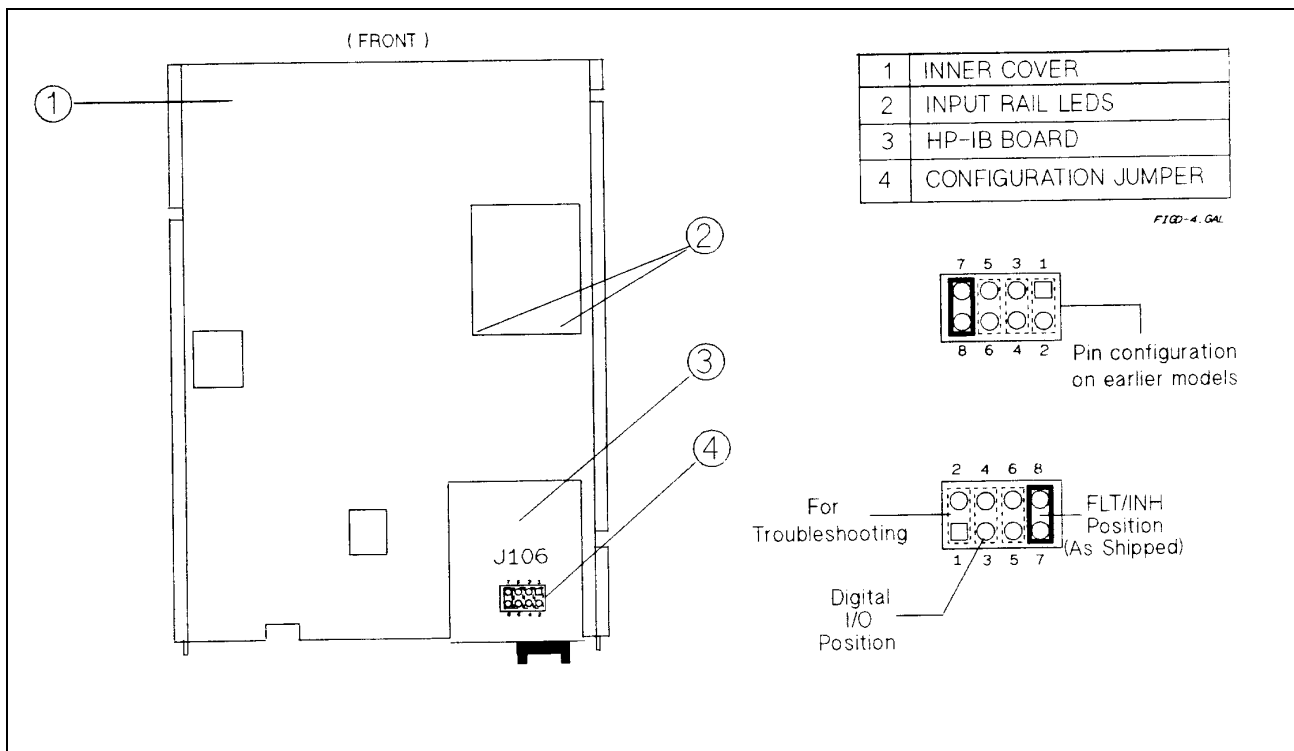

Figure F-4. Digital Port Configuration Jumper

Digital I/O Operation

The digital port can be configured (see Figure F-4) to provide a digital input/output to be used with custom digital interface circuits or relay circuits. Some examples are shown Figure F-5. See Figure F-1 for the pin assignments of the mating plug and Appendix A for the electrical characteristics of the port. See **DIG:DATA[:VAL]** in "Chapter 7 - Language Dictionary" for information on programming the port. The digital port pins are as follows:

- OUT 0** (pin 1) This port can only be used as an open-collector output. It is assigned a bit weight of 1.
- OUT 1** (pin 2) This port can only be used as an open-collector output. It is assigned a bit weight of 2.
- IN/OUT 2** (pin 3) This port can be programmed to be either an input, or an open-collector output with an internal 4.6 k pull-up to 5 V.
- Common** (pin 4) This pin is the common connection for the Digital I/O ports.

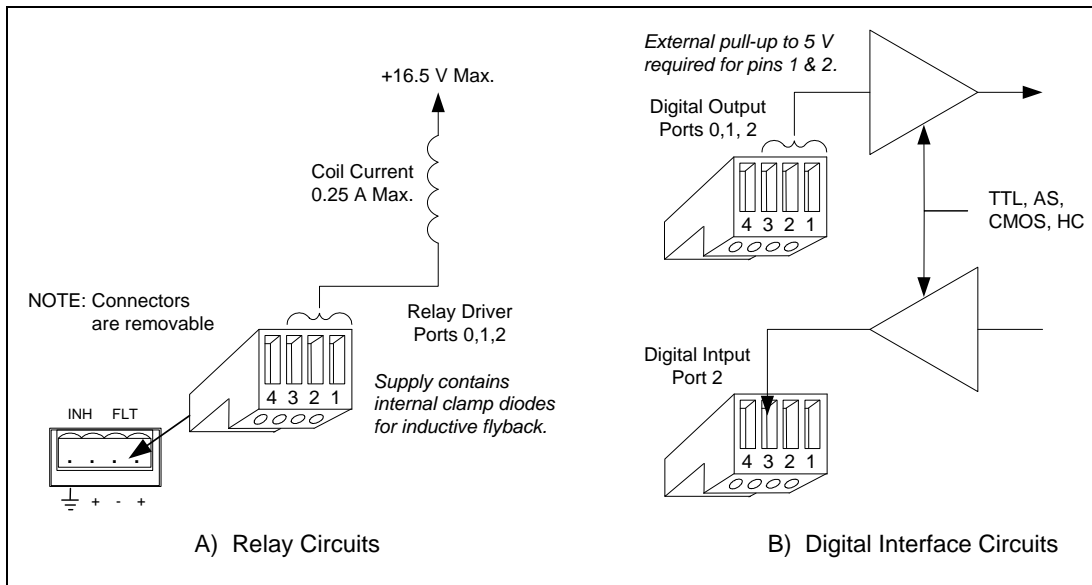

Figure F-5. Digital I/O Port Applications

Relay Link Operation

The digital port can be configured to provide relay control outputs for the Keysight 59510A or 59511A Relay Accessory. Refer to Figure F-1 for the pin assignments of the mating plug.



Not used with units that output more than 50 amps.

- RLY SEND** (pin 1)
(pin 2 is not used) Provides the serial data to control the relays in the Relay Accessory.
- RLY RTN** (pin 3) Receives the data readback that indicates the status of the relays in the Relay Accessory.
- Common** (pin 4) Common connection for the RLY SEND and RLY RTN lines.

Figure F-6 shows how to connect your power supply to an Keysight 59510A or 59511A Relay Accessory when the digital port is configured for relay link operation. *An error will be generated if you attempt to program the relay box without first configuring the digital port for relay link operation.* For more information about programming the relay, refer to **OUTP:REL[:STAT]** in Chapter 7. For more information about the Relay Accessory, refer to its manual (see Table 1-4).

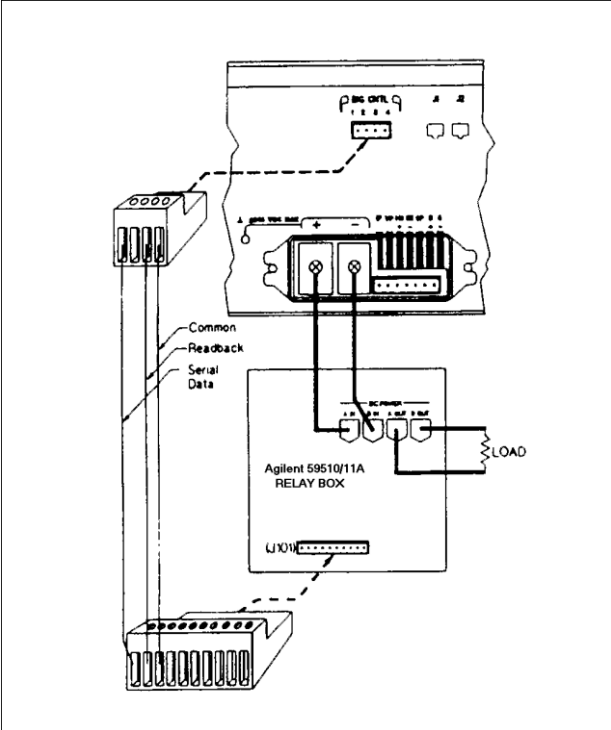

Figure F-6. Relay Link Connections

Compatibility Language

Introduction

This power supply is programatically compatible with the Keysight 603xA Series AutoRanging Power Supplies (ARPS). This means that you can program this power supply over the GPIB using the ARPS commands. Software that you have written for the autoranging power supplies can also be adapted to program this power supply.

Note The Keysight E4356A Power supply's serial link is not supported by ARPS commands. You can use only a GPIB primary address for the power supply.

To switch from SCPI commands to ARPS commands (and vice versa), use the SYST:LANG command. This command is documented in Chapter 7.

Table G-1 summarizes the ARPS commands that program the supplies. You will need to refer to the Series 603xA power supply manual (see Table 1-4) for complete information on the ARPS commands. Some of the ARPS commands are simlax to SCPI commands, but others are unique to ARPS. For example, the ARPS FOLD commands have no function with the Keysight E4356A power supplies. Similarly, there are some SCPI commands that have no ARPS function.

Parallel Polling

When programmed for parallel polling and Compatibilty Language, power supplies operating under the Keysight BASIC system can "hang up" the GPIB when the system is turned on. This can occur under the following conditions:

- The controller uses CS80 Protocol for an external disk drive (for example, the Keysight 9133D).
- The external disk drive and the power supply have the same select code and that code is 7 or less.
- The external disk drive and power supply addresses are binary complements of each other (e.g., 0 & 7, 1 & 6, etc.)

When the system is turned on, the power supply accesses the GPIB before the controller and prevents it from accessing the external disk drive. The solution is to change one of the GPIB addresses, or to ensure that the power supply is not turned on until after the controller has completed its selftest and has control of the GPIB.

Table G-1. ARPS Commands

ARPS Command ¹	Description	Similar SCPI Command
VSET x VSET xV VSET xMV	These commands program output voltage. See Table 7-1 for the programming ranges of these commands. Initial condition: 0 V	VOLT
ISET x ISET xA ISET xMA	These commands program output current. See Table 7-1 for the programming ranges for these commands. Initial condition: 0 A	CURR
VSET? ISET?	These commands read voltage or current settings.	VOLT? CURR?
VOLT? IOUT?	These commands measure and read output voltage or current.	MEAS:VOLT? MEAS:CURR?
OVP x OVP xV OVP xMV	NOTE: OVP commands do not work with Keysight 603xA supplies. These commands program the overvoltage protection. The OVP setting is programmed in either volts or millivolts. See Table 7-1 for the programming ranges of these commands. Initial condition: 10% above rated output.	VOLT:PROT
OVP?	This command reads the OVP setting.	VOLT:PROT?
VMAX x VMAX xV VMAX xMV	These commands program an upper limit (soft limit) to the voltage programming value that the power supply will accept. The programming ranges are the same as those used for VSET.	(None)
IMAX x IMAX xA IMAX xMA	These commands program an upper limit (soft limit) to the current programming value that the power supply will accept. The programming ranges are the same as those used for ISET.	(None)
VMAX? IMAX?	These commands read the soft voltage or current limits.	(None)
DLY x DLY xS DLY xMS	These commands program the delay time before a new output voltage or current is implemented or an RST , OUT ON , or CLR command is received. During the delay the CV, CC, and CR conditions cannot be reported as faults, and foldback protection is disabled.	OUTP:PROT:DEL
DLY?	This command reads the delay time setting.	OUTP:PROT:DEL?
OUT OFF OUT 0 OUT ON OUT 1	These commands enable or disable the power supply output. The disabled state programs the output to relatively low voltage and current values. The unit will be able to implement commands even while the output is disabled. Initial condition: OUT ON	OUTP:STAT OFF OUTP:STAT 0 OUTP:STAT ON OUTP:STAT 1
FOLD OFF FOLD CC FOLD 2 FOLD 0 FOLD CV FOLD 1 FOLD CC FOLD 2	These commands enable or disable Foldback protection. Foldback protection disables the power supply output if the power supply switches to whichever mode (CV or CC) is defined as the fold (error) condition. Note that foldback protection is disabled during the DELAY period. Initial condition: FOLD OFF	(None)
FOLD?	This command reads the Foldback setting.	(None)
¹ x = any digit (within range) MA = milliampere MV = millivolt MS = millisecond.		

Table G-1. ARPS Commands (continued)

ARPS Command ¹	Description	Similar SCPI Command
RST	This command resets the power supply if the output is disabled by the overvoltage, remote inhibit, or foldback protection circuits. The power supply resets to the parameters stored for the power-on state. Note that the settings can be changed while the unit is disabled.	OUTP:PROT:CLE
HOLD OFF HOLD 0 HOLD ON HOLD 1	These commands determine if certain newly received commands are immediately acted on by the power supply or are acted on later while the unit continues to operate with previously received values. HOLD ON can be used to synchronize power supply actions with the actions of other GPIB devices. (See the TRG command.) Initial condition: HOLD OFF	VOLT:TRIG CURR:TRIG
HOLD?	This command reads the HOLD setting.	VOLT:TRIG? CURR:TRIG?
T TRG	These commands cause the power supply to act on commands that have been previously sent, but are being held (pending). The unit continues to operate with previously received values until a trigger command is received (see HOLD command.) The device trigger interface message performs the same function.	INIT ON;TRIG INIT ON;*TRG
STO RCL	These commands cause the power supply to store and recall power supply states, except for output on/off. Each state includes: voltage (1st and 2nd rank), current (1st and 2nd rank), soft voltage and current limit, delay time, service request on/off, foldback (1st and 2nd rank), mask (1st and 2nd rank), and hold. Initial condition: Each register is initiated to the turn-on values.	*SAV *RCL
STS?	This command reads the contents of the status register, which maintains the present status of the power supply.	STAT:OPER:COND? STAT:QUES:COND? *ESE?
ASTS?	This command reads the contents of the accumulated status register, which stores any bit condition entered in the status register since the accumulated status register was last read, regardless of whether the condition still exists.	STAT:OPER? STAT:QUES? *ESE?
UNMASK mnemonics UNMASK xxx	These commands determine the conditions that will set bits in the fault register, allowing the operator to define the conditions that will be reported as faults. Fault conditions can be enabled by sending a string of status register mnemonics after the UNMASK command. The mnemonics must be separated by commas, and may be sent in any order, but must correspond to the condition that will be enabled. Fault conditions can also be enabled by sending the decimal equivalent of the total bit weight of all conditions to be enabled. UNMASK NONE disables all conditions from setting bits in the fault register. Initial condition: UNMASK NONE	STAT:OPER:ENAB STAT:QUES:ENAB *ESE

Table G-1. ARPS Commands (continued)

ARPS Command ¹	Description	Similar SCPI Command
UNMASK?	This command reads which bits in the status register have been enabled as fault conditions. The decimal equivalent of the total bit weight of all enabled bits is returned.	STAT:OPER:ENAB? STAT:QUES:ENAB? ESE
FAULT?	This command reads which bits have been set in the fault register. A bit is set in the fault register when the corresponding bit in the status register changes from inactive to active AND the corresponding bit in the mask register has been enabled. The fault register is reset only after it has been read. The decimal equivalent of the total bit weight of all enabled bits is returned.	STAT:OPER? STAT:QUES? *ESE
SRQ OFF SRQ 0 SR*Q ON SRQ 1	These commands enable or disable the power supply's ability to request service from the controller for fault conditions. UNMASK defines which conditions are defined as faults. Initial condition: SRQ OFF	*SRE
SRQ?	This command reads the SRQ setting.	*SRE?
CLR ERR?	This command initializes the power supply to the power-on state. It also resets the PON bit in the serial poll register. The command performs the same function as the Device Clear (DCL) interface message. This command determines the type of programming error detected by the unit. A remote programming error sets the ERR bit in the status register, which can be enabled by UNMASK to request service.	*RST SYST:ERR?
TEST?	This command causes the power supply to run selftest and report any detected failures.	*TST?
ID?	This command causes the power supply to report its model number and any options that affect the unit's output.	*IDN?
SYST:LANG	This command causes the alternate language to become active and to be stored in nonvolatile memory. In this case, the commands are equivalent. After being shut off, the power supply will resume in the last-selected language when power is restored. The parameter must be either COMP or TMSL , not SCPI .	SYST:LANG

Service Addendum

Introduction

This addendum contains information for troubleshooting and repairing the Keysight E4356A Telecommunications DC Power Supply. The standard service manual for the Keysight Series 667xA DC Power Supplies (p/n 5959-2583) is shipped with the Keysight E4356A when ordered with Option 0BN. This manual must be used together with this service addendum.

This addendum was formerly identified by part number 5964-8170. It applies to units with serial numbers US39290101 and up.

NOTE: This addendum is to be used along with the standard service manual for the Keysight Series 667xA DC Power Supplies. When troubleshooting, follow the procedures outlined for Keysight Model 6674A. This addendum documents only the differences between the standard troubleshooting procedures for Keysight Model 6674A and the Keysight E4356A Telecommunications DC Power Supply.

Areas of Difference

- ◆ Voltage and Current Values (Table 2-2).
- ◆ Performance Test Record (Table 2-19).
- ◆ Initialization Program listing (Figure 3-18).
- ◆ Parts list (Tables 5-3, 5-4, 5-6, 5-9, 5-10 and 5-11).

Chapter 2 Differences

Voltage and Current Values – page 2-4

Table 2-2. Programming Voltage and Current Values

Keysight Model	Full-Scale Voltage	Max. Prog. Voltage	Full-Scale Current	Max. Prog. Current	Max. Prog. OverVoltage
Keysight E4356A	80	81.9	30	30.71	96

Table 2-12. Verification Test Record for Keysight Model E4356A

Model: Keysight E4356A		Report No. _____	Date _____	
Test Description	Minimum Specification	Recorded Results*	Maximum Specification	Measurement Uncertainty
Constant Voltage Tests				
Voltage Programming and Readback				
Low Voltage (0 V) V_{out}	-80 mV	_____ mV	+80 mV	2.2 μ V
Front Panel Display Readback	V_{out} -120 mV	_____ mV	V_{out} +120 mV	2.2 μ V
High Voltage (80 V) V_{out}	79.888 V	_____ V	80.112 V	0.8 mV
Front Panel Display Readback	V_{out} -160 mV	_____ mV	V_{out} +160 mV	0.8 mV
Load Effect	V_{out} -4.6 mV	_____ mV	V_{out} +4.6 mV	40 μ V
Source Effect	V_{out} -4.6 mV	_____ mV	V_{out} +4.6 mV	40 μ V
PARD (Ripple and Noise)				
peak-to-peak	0	_____ mV	16 mV	904 μ V
rms	0	_____ mV	1.9 mV	150 μ V
Transient Response Time (@900 μs)	0	_____ mV	100 mV	12 mV
Constant Current Tests				
Current Programming and Readback				
Low Current (0 A) I_{out}	-25 mA	_____ mA	+25 mA	153 μ A
Front Panel Display Readback	I_{out} -30 mA	_____ mA	I_{out} +30 mA	153 μ A
High Current (30 A) I_{out}	29.945 A	_____ A	30.055 A	5.7 mA
Front Panel Display Readback	I_{out} -65 mA	_____ mA	I_{out} +65 mA	5.7 mA
Load Effect	I_{out} -3.75 mA	_____ mA	I_{out} +3.75 mA	21 μ A
Source Effect	I_{out} -3.75 mA	_____ mA	I_{out} +3.75 mA	21 μ A
PARD (Ripple and Noise)				
rms	0	_____ mA	25 mA	5 mA
Current Sink (4A) Display Readback	I_{out} -34 mA	_____ mA	I_{out} +34 mA	0.6 mA

* Enter your test results in this column.

Chapter 3 Differences

Initialization Program Listing - page 3-38

In Figure 3-18, change line 160 to read:

```
160 DATA 169,170,171,172,174,176,180
```

Change line 230 to read:

```
230 DATA 1,1,1,2,1,4,4
```

Add the following lines to Figure 3-18 after line 590:

```
591 Eprom_data_4356: !                               ! EEPROM data for E4356A
592 DATA 458.923,70,81.9,0,82,0,80,70,26.6175,0
593 DATA 99,1,50,0,96,0,82,255,20,10
594 DATA 4356,55,500,90,500,1765,5,255,0,0
595 DATA 1296,4356,0,20,180,20,174,175,33,98
596 DATA 115,30,20,1,58,71.6625,30.7125
597 !
```

Add the following lines after line 980:

```
981 CASE "4356A"
982 RESTORE Eprom_data_4356
```

Change line 1030 to read:

```
1030 PRINT "6671A, 6672A, 6673A, 6674A, 6675A and E4356A"
```

Change lines 660, 720, 1070, and 1600 to read:

```
FOR I=1 TO 47
```

Chapter 5 Differences

Table 5-3. Main Chassis

Ref. Des.	Keysight Part No.	Description
ELECTRICAL PARTS		
A1	E4356-61023	Front panel pc assembly, tested
A2	5063-4851	GPIB pc assembly, tested
A3	5060-3338	FET pc assembly, tested
A5	E4356-61020	Control pc assembly, tested
A6	E4356-61022	Output pc assembly, tested
A7	E4356-61026	Snubber pc assembly, tested (mounted on heatsink)
D900	1906-0451	Diode, rectifier UTF12780 (mounted on heatsink)
L900	06674-80005	1 st stage output choke
T900	9100-4976	Transformer, power output
C999	E4356-60026	Capacitor assembly 220 pF, 1.6kV (mounted on D900)
MECHANICAL PARTS		
E4356A	E4356-80001	Nameplate

Table 5-4. A1 Front Panel Board

Ref. Des.	Keysight Part No.	Description
U4	5080-2278	Programmed ROM (installed in socket)

Table 5-6. A2 GPIB Board

Ref. Des.	Keysight Part No.	Description
U106	5080-2243	Programmed ROM (installed in socket)

Table 5-9. A5 Control Board

Ref. Des.	Keysight Part No.	Description
ELECTRICAL PARTS		
C683	0160-5468	Capacitor 0.47 μ F, 50 V
C716	0160-4835	Capacitor 0.1 μ F
R504	0698-6392	Resistor 22k, 0.1 %
R651, 652	0757-0476	Resistor 301k
R665, 6664	0757-0199	Resistor 21.5k
R690	0698-8827	Resistor 1M
R691	0757-0465	Resistor 100k
R718	0698-8695	Resistor 36k, 0.1 %
R730, 731	0699-0934	Resistor 36.65k, 0.1 %
R768	8159-0005	Resistor 0 ohms
R809	0699-0769	Resistor 17.5k, 0.1 %

Table 5-10. A6 Output Board

Ref. Des.	Keysight Part No.	Description
ELECTRICAL PARTS		
C901, 903, 905	0180-4705	Capacitor 6000 μ F, 100V
Q903	1855-1003	Transistor IRFIP-240
R909, 910	0698-3644	Resistor 5.1k, 2W
R934	0698-0082	Resistor 464 ohms

Table 5-11. A7 Snubber Board

Ref. Des.	Keysight Part No.	Description
ELECTRICAL PARTS		
C990, 991	0160-5466	Capacitor 1000 pF, 100V
R990- 995	0698-3634	Resistor 470 ohms

Index

<bool>, 51
<NR1>, 51
<NR2>, 51
<NR3>, 51
<NRf+>, 51
<NRf>, 51

—<—

—A—

AARD, 51
accessories, 14
active header
 path, 47
airflow, 18
analog
 connector, 17
analog connector, 27
annunciators
 Addr, 38
 AMPS, 38
 Cal, 38
 CC, 38
 CV, 38
 Dis, 38
 Err, 38
 OCP, 38
 Prot, 38
 Rmt, 38
 Shift, 38
 SRQ, 38
 Unr, 38, 42
 VOLTS, 38
Arps commands, 122
auto-parallel connections, 32
auto-parallel programming, 33
AWG wire size, 27

—B—

battery charging, 29

—C—

cables, 14
calibration
 equipment, 99
 example, 105
 GPIB, 102
 password, 100, 102
 procedure, 101
 saving, 100
 setup, 99
calibration commands
 CAL CURR, 103

 CAL CURR LEV, 103
 CAL PASS, 103
 CAL SAVE, 103
 CAL STAT, 104
 CAL VOLT, 104
 CAL VOLT LEV, 104
 CAL VOLT PROT, 104
calibration errors, 102
capacitive loads, 28
cc mode, 16, 42
character strings, 51
characteristics, 96
 output, 16
checkout
 in case of trouble, 24
 output current, 23
 output voltage, 22
 power-on, 21
 preliminary, 21
 replacing fuse, 25
 save and recall, 24
checksum errors, 26
combine commands
 common commands, 48
 root specifier, 48
command completion, 52
command summary, 85
common command syntax, 64
common commands
 *CLS, 64
 *ESE, 65
 *ESR?, 65
 *IDN?, 66
 *OPC, 66
 *OPC?, 67
 *OPT?, 67
 *PSC, 67
 *RCL, 68
 *RST, 69
 *SAV, 69
 *SRE, 70
 *STB?, 70
 *TRG, 71
 *TST?, 71
 *WAI, 71
Compatibility language, 121
connection
 +LS, 30
 -LS, 30
 sense leads, 30
connections
 auto-parallel, 32
 controller, 35
 external voltage control, 34
 multiple load, 32
 output, 29
 series, 33
 single load, 31

- connector
 - analog, 27
 - digital, 28
- controller connections, 35
 - linked, 35
 - stand-alone, 35
- conventions, 46
- CRD, 51
- current monitor resistor, 107
- current programming, 41, 53
- current sinking, 16
- cv mode, 16, 42

—D—

- damage, 17
- description, 15
- detecting SRQ events, 54
- DFI discrete fault indicator, 90
- digital connector, 17, 28, 115
- digital I/O, 28
- digital I/O programming, 55
- digital port configuration, 117
- dimensions, 18
- direct unit, 35, 43, 55
- display
 - text, 54
- DOS drivers, 57
- downprogramming, 16

—E—

- entry keys
 - ←(backspace), 39
 - ↑Current, 39
 - ↑Voltage, 39
 - 0 - 9, 39
- equivalent series resistance, 29
- error handling, 57
- error messages
 - calibration, 102
 - checksum, 26
 - power-on, 25
 - runtime, 26
 - selftest, 25
 - system, 111
- example programs, 57
- external voltage control, 34

—F—

- fan, 18
- fault/inhibit, 28
- FLT indicator, 90
- FLT output, 115
- front panel, 37
 - annunciators, 38
- function keys
 - Current, 39
 - OCP, 39

- Output On/Off, 39
- OV, 39
- Prot Clear, 39
- Protect, 39
- Voltage, 39

- fuse
 - location, 25
 - replacing, 25

—G—

- ground, earth, 13
- guide, user's, 13

—H—

- header, 49
 - long form, 49
 - short form, 49
- history, 5
- GPIB
 - capabilities, 46
 - command library for MS DOS, 45
 - controller programming, 45
 - references, 45
- GPIB address, 24, 43, 55
 - assigning in programs, 56
 - changing, 44, 55

—I—

- IM, 27
- IN/OUT 2, 118
- inductive loads, 29
- INH common, 115
- INH indicator, 90
- INH input, 115
- initial conditions, 40
- input
 - connections, 18
 - power, 14
 - rating, 18
- inspection, 17
- installation
 - VXIplug&play, 20
- IP-, 27
- IP+, 27

—L—

- language dictionary, 63
- line connections
 - 3-phase, 18
- line fuse, 18
- line select switch, 113
- line voltage conversion, 113
- linked connections, 35
- linked unit, 35, 43, 55
- load, battery, 29
- load, capacitive, 28

load, inductive, 29
local voltage sensing, 30
location, 18

—M—

master unit, 32
message terminator, 50
message unit
 separator, 50
moving among subsystems, 48
multiple load connections, 32
multipliers, 51

—N—

NTR filter, 92
numerical data format, 51

—O—

OCP
 checking, 42
 clearing, 42
 programming, 42, 53
 setting, 42
operating curve, 40
operation status group, 87
optional headers
 effect, 47
options, 14
output queue, 90
OUT 0, 118
OUT 1, 118
output
 rating, 16
output connections, 29
output impedance, 98
output isolation, 28
OVP
 checking, 41
 clearing, 41
 programming, 40, 53
 setting, 41

—P—

P com, 27
parallel polling, 121
parts list, 14
power cord, 17
 installing, 18
power receptacle, 13
power-on, 43
 register states, 91
power-on errors, 25
status registers, 91
primary address, 44, 55
print date, 5
program examples, 57

programming
 analog, 16
 auto-parallel, 33
 current, 41, 53
 digital I/O, 55
 external voltage, 34
 front panel, 15
 overcurrent protection (OCP), 42, 53
 overvoltage protection (OVP), 40, 53
 parameters, 86
 remote, 15
 service request, 92
 status, 54
 triggers, 53
 voltage, 40, 53
PTR filter, 92

—Q—

queries, 48
query indicator, 50
questionable status group, 89

—R—

rack mount kit, 14
rack mounting, 18
reading status registers, 54
recalling states, 43, 54
relay link, 28
remote voltage sensing, 30
 CV regulation, 30
 output noise, 30
 output rating, 30
 OVP considerations, 31
 stability, 31
repacking, 17
replaceable parts, 14
reverse protection diode, 33
RI remote inhibit, 90
RLY RTN, 118
RLY SEND, 118
root specifier, 50
runtime errors, 26

—S—

S-, 27
S+, 27
safety
 symbol, 4
 warning, 3
safety class, 13
safety warning, 13
saving states, 43, 54
SCPI
 command completion, 52
 command tree, 46
 common commands, 46
 conformance, 62

- data format, 51
- header path, 47
- message structure, 49
- message types, 49
- message unit, 49
- multiple commands, 47
- non-conformance, 62
- program message, 49
- queries, 48
- references, 45
- response message, 49
- subsystem commands, 46, 72
- secondary address, 44, 55
- selftest errors, 25
- serial cable, 17
- series connections, 33
- service request, 91
 - programming, 92
- service request enable register, 90
- servicing status events, 92
- shift function, 37, 38
- single load connections, 31
- slave unit, 32
- specifications, 95
- SRQ events
 - detecting, 54
- SRQ service request, 91
- stand-alone connections, 35
- standard event status group, 89
- status bit
 - CAL, 88
 - CC, 88
 - CME, 88
 - CV, 88
 - DDE, 88
 - ESB, 88
 - EXE, 88
 - MAV, 88
 - MSS, 88, 90
 - OC, 88
 - OPC, 88
 - OPER, 88
 - OT, 88
 - OV, 88
 - PON, 88, 91
 - QUES, 88
 - QYE, 88
 - RI, 88
 - RQS, 88, 90
 - UNR, 88
 - WTG, 88
- status byte register, 90
- status registers, 87
 - configuration, 88
- subsystem commands
 - ABOR, 72
 - CURR PROT STAT, 73
 - CURR, CURR TRIG, 73
 - DIG DATA, 74
 - DISP, 74
 - DISP MODE, 75

- DISP TEXT, 75
- INIT, INIT CONT, 76
- MEAS CURR, MEAS VOLT, 76
- OUTP, 77
- OUTP PROT CLE, OUTP PROT DEL, 77
- OUTP REL, 78
- OUTP REL POL, 78
- STAT OPER COND?, 79
- STAT OPER ENAB, 79
- STAT OPER NTR, STAT OPER PTR, 80
- STAT OPER?, 79
- STAT PRES, 78
- STAT QUES COND?, 81
- STAT QUES ENAB, 81
- STAT QUES NTR, STAT QUES PTR, 81
- STAT QUES?, 80
- SYS ERR?, 82
- SYS LANG, 82
- SYS VERS?, 82
- TRIG, 83
- TRIG SOUR, 83
- VOLT PROT, 84
- VOLT, VOLT TRIG, 83
- suffixes, 51
- support rails, 18
- system errors, 111
- system keys
 - (shift), 39
 - Address, 39, 44, 55
 - Error, 39
 - Local, 39
 - Recall, 39
 - Save, 39

—T—

- temperature range, 18
- trigger
 - continuous, 53
 - initiate, 53
 - single, 53
- triggering the output, 53
- turn-on conditions, 43
- types of SCPI commands, 46

—U—

- unregulated operation, 42

—V—

- value coupling, 48
- verification
 - current programming, 109
 - current readback, 109
 - equipment, 107
 - test record, 110
 - test setup, 107
 - voltage programming, 108
 - voltage readback, 108

voltage programming, 40, 53
voltage sensing, local, 30
voltage sensing, remote, 30
VP, 27
VXIplug&play, 13, 20

—W—

warranty, 2
wire capacity, 27
wire resistance, 27
wire size, 27
writing to the display, 54

Keysight Sales and Support Offices

For more information, call your local Keysight sales office listed in your telephone directory or a Keysight regional office listed below for location of your nearest sales/support office.

United States of America:

Keysight Technologies Company
Test and Measurement Organization
5301 Stevens Creek Blvd
Bldg 51L-5C
Santa Clara, CA 95052-8059
(800) 452 4844

Asia Pacific:

Keysight Technologies Asia Pacific Ltd.
17-21/F Shell Tower, Time Square
1 Matheson Street, Causeway Bay,
Hong Kong
(852) 2599 7070

Australia/New Zealand:

Keysight Technologies Australia Ltd.
31-41 Joseph Street
Blackburn, Victoria 3130
Australia
131 347 ext. 2902

Canada:

Keysight Technologies Canada Ltd.
5150 Spectrum Way
Mississauga, Ontario L4W 5G1
(905) 206 4725

Europe:

Keysight Technologies
European Marketing Centre
P.O. Box 999
1180 AZ Amstelveen
The Netherlands

Japan:

Yokogawa Keysight Technologies Ltd.
Measurement Assistance Center
9-1, Takakura-Cho, Hachioji-Shi,
Tokyo, 192, Japan
(81) 426 48 3860

Latin America:

Keysight Technologies
Latin American Region Headquarters
5200 Blue Lagoon Drive
9th Floor
Miami, Florida 33126
U.S.A.
(305) 267 4245/4220



This information is subject to change without notice.
© Keysight Technologies 1999, 2015
Edition 2, January 2015



5964-8166

www.keysight.com