

## Features

**Broadband** - 26.5 GHz to 40 GHz

**High Gain** - Lower Floor Noise for Emissions

**Individual Calibration**

**Two Year Warranty**



## Description

Model AH-640 is a broadband linearly polarized double ridged waveguide horn antenna designed specifically for Electromagnetic Interference testing. This antenna can be used for receive as well as transmit applications for the frequency range of 26.5 GHz - 40 GHz.

This antenna has a high gain; at least 23 dBi over the entire frequency range. This antenna can accept up to 5 Watts of input power at its terminals in continuous mode in the applicable frequency range for generating electromagnetic fields.

The AH-640 Horn antenna has a K type connector which can mate with SMA type connectors. The antenna is constructed using lightweight aluminum with a corrosion resistant finish. The oval rear plate has a 1/4" x 20 threaded hole for mounting to the Com-Power AT-100 tripod.

The antenna is individually calibrated at 1 meter and data and certificate of calibration will be shipped with the antenna. The data will include the antenna factor and antenna gain.

## Application

The AH-640 was designed for EMC testing, but it can also be used for antenna gain pattern measurements, surveillance, and other applications. The wide frequency band makes the AH-640 antenna suitable for sweep measurements, reducing the need for antenna switching during the test.

High gain reduces input power requirements to achieve the desired field levels for immunity testing and improves antenna sensitivity to low level signals. During emissions testing the measured field strength can be calculated by adding the antenna factor for the particular frequency to voltage measured at the antenna output terminal.

For immunity testing, the input power requirement **P** in Watts to generate **E** electric field strength in V/m at a distance **D** in meters can be calculated by using the following formula:

$$P = E^2 \times D^2 / 30 \times N$$

$$N = 10^{(G/10)}$$

$$G = 20 \log F - 29.79 - AF$$

Where

**N** = Numeric Gain

**G** = gain in dBi

**F** = Frequency in MHz

**AF** = antenna factor in dB/m

# Specifications

**Frequency Range:** 26.5 GHz - 40 GHz  
**Power handling:** 5 Watts CW  
**VSWR:** 2.0 :1.0  
**Polarization:** Linear  
**Connector type:** K type (will mate with SMA)  
**Impedance:** 50 Ohms  
**Weight:** 1.5 lbs. (0.68 kg) max.  
**Size (L x W x H):** 8.7 x 5.7 x 9 inches max.  
 22 x 14.5 x 22.8 cm max.

## Typical Antenna Factors:

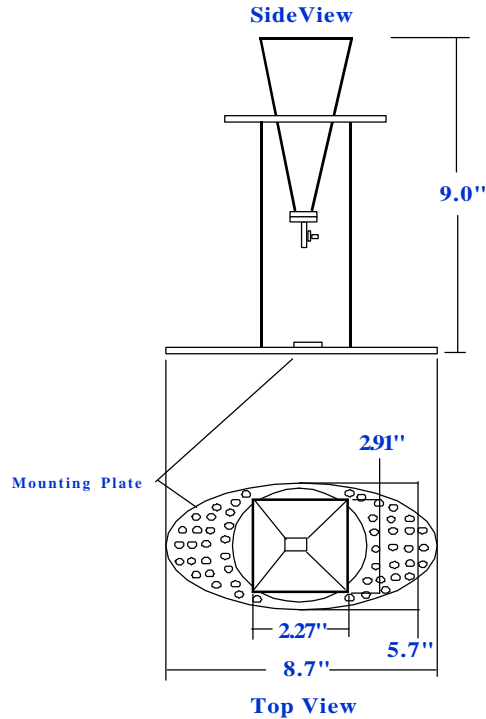
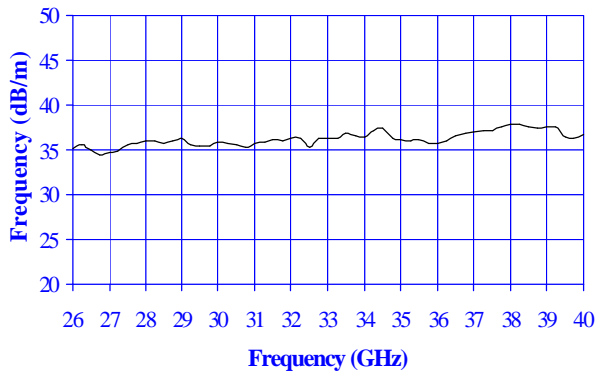

$$\text{Field strength (dBV/m)} = \text{Output measured (dBV)} + \text{Antenna Factor (dB/m)}$$

Typical Antenna Gain & Power requirement in Watts at a one meter distance to obtain field strength in V/m:

Freq. Ghz	Gain (dBi)	Freq. GHz	Field Strength		
			V/m	V/m	V/m
			<b>10</b>	<b>20</b>	<b>100</b>
26	23.41	26	0.02	0.06	1.52
27	24.24	27	0.01	0.05	1.26
28	23.25	28	0.02	0.06	1.58
29	23.26	29	0.02	0.06	1.57
30	23.95	30	0.01	0.05	1.34
31	24.44	31	0.01	0.05	1.20
32	24.11	32	0.01	0.05	1.29
33	24.28	33	0.01	0.05	1.24
34	24.44	34	0.01	0.05	1.20
35	24.99	35	0.01	0.04	1.06
36	25.64	36	0.01	0.04	0.91
37	24.57	37	0.01	0.05	1.16
38	24.01	38	0.01	0.05	1.33
39	24.53	39	0.01	0.05	1.17
40	25.55	40	0.01	0.04	0.93

All values are typical values unless specified.  
All specifications are subject to change without notice.