

CNI 508N2 COUPLING NETWORK

COUPLING/DECOUPLING ASSEMBLY FOR UNSHIELDED AND SHIELDED HIGH-SPEED COMMUNICATION LINES UP TO 1GBIT/S



FOR TESTS ACCORDING TO ...

- › EN 61000-4-12
- › EN 61000-4-4
- › EN 61000-4-5
- › EN 61000-6-1
- › EN 61000-6-2
- › IEC 61000-4-12
- › IEC 61000-4-4
- › IEC 61000-4-5

COUPLING/DECOUPLING ASSEMBLY FOR UNSHIELDED AND SHIELDED HIGH-SPEED COMMUNICATION LINES

The EM TEST CNI 508N2 is the first coupling/decoupling network available on the market to couple Surge onto shielded and unshielded high-speed communication lines with data rates up to 1,000MBit/s.

Additionally, the CNI 508N2 can be used as a coupling/decoupling network to apply Burst- as well as Ringwave pulses to shielded lines. The CNI 508N2 meets the requirements according to the standards IEC 61000-4-5 (Ed. 2.0 : 2005) Figure 15 and Figure 16 and the draft IEC 61000-4-5 (Ed. 3.0 : 2012) Figure 11 and Figure 12.

HIGHLIGHTS

- › **Coupling to unshielded and shielded lines with up to 4 pairs**
- › **Data transfer up to 1,000MBit/s**
- › **Residual voltage max. 40V at 3kV**
- › **Surge test voltage up to 3kV (1.2/50us)**
- › **Burst test voltage up to 4kV (5/50ns)**
- › **Ringwave test voltage up to 3kV (0.5us/100kHz)**
- › **Compatible to PoE and PoE+ requirements**

APPLICATION AREAS

-  TELECOM
-  INDUSTRY
-  RESIDENTIAL
-  MILITARY

TECHNICAL DETAILS

CNI 508N2 - COUPLING- DECOUPLING NETWORK

COUPLING NETWORK FOR COUPLING OF THE SURGE, BURST AND RINGWAVEIMPULSE TO UNSHIELDED AND SHIELDED HIGH-SPEED COMMUNICATION LINES

The CNI 508N2 is specially designed for the testing of high-speed communication lines. It allows data transfers up to 1,000 Mbit / s without affecting the signal.

It also supports PoE and PoE + standard requirements as per IEEE 802.3af-2003 and IEEE 802.3at-2009.

The CNI 508N2 includes two surge pulse inputs. One for the direct coupling to lines and one for coupling to the cable shield (see tests to shielded cables as per IEC 61000-4-5).

Surge: Direct coupling

Using series resistors, as specified in the standard, the surge pulses are coupled onto the unshielded symmetrical Interconnection lines.

The coupling network includes all necessary resistors and coupling elements to couple the 1,2 / 50us impulse (max. 3 kV) up to 4 pairs of high-speed communication lines.

The picture below shows the normative design of the coupling-decoupling network.

Fig. 15 IEC 61000-4-5 (Ed. 2.0 :2005)

Fig. 11 Draft IEC 61000-4-5 (Ed. 3.0 :2012)

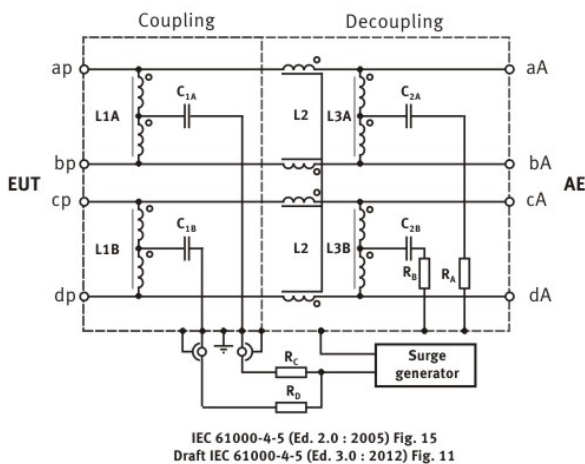

COUPLING TO THE SCREENED LINES

TEST OF SHIELDED LINES

Up today, the surge test on shielded data cable had a complicated and hazardous test setup with long cables and additional galvanically isolated power supplies.

With the innovative CNI 508N2 this test / test setup get much easier. The accessory is correct decoupled and the surge pulse is coupled directly to the shield of the tested cable and not applied to the conductive housing.

The CNI 508N2 allows further test requirements: Burst and Ringwave pulses (0.5 us/100 kHz) with coupling to shielded cables.

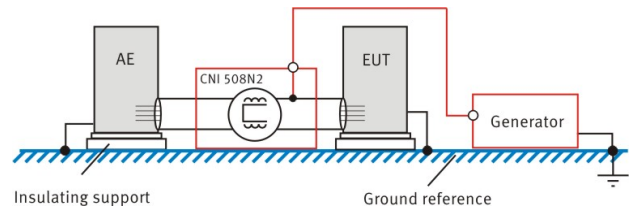

POE UND POE+ REQUIREMENTS

TEST SET-UP WITH POE AND POE+ SUPPLY

The power supply input for PoE and PoE + applications is on the protected side (AE) of the coupling / decoupling network.

The power supply is fed through the CNI 508N2 to the DUT. The voltage range for PoE and PoE + supplies is standardized from 36V to 57V.

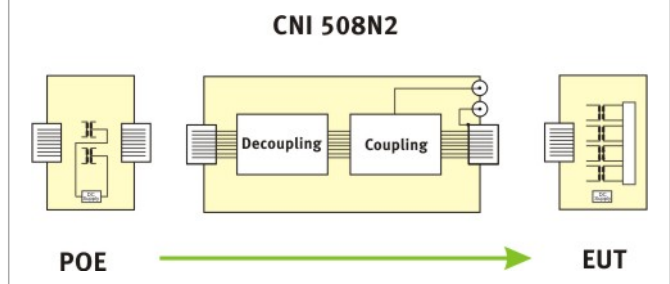

TECHNICAL DETAILS**CONNECTION AE PORT****DEVICE PROTECTION ON AE PORT**

The impulse at the AE-port of the decoupling network is damped. The CNI 508N2 has an additional integrated overvoltage protection that limits the residual voltage below 40 V between line and earth.

This protection level allows to use PoE (Power over Ethernet) power supply inside the specified voltages range from 36V to 57V.

This protection level is for some application cases too high and can destroy your expensive auxiliary equipment connected at the AE port. Thus EM TEST has developed an additional protective element SPN 508N1

SPN 508N1 SURGE PROTECTION OPTION**SURGE PROTECTION NETWORK FOR UNSHIELDED AND SHIELDED HIGH-SPEED COMMUNICATION LINES**

The optional SPN 508N1 is required to appropriately decouple the surge pulses from the auxiliary equipment. The residual voltage at the AE port is limited to max. 10V@2kV surge voltage level. Its specific design allows the full data transfer up to 1000 MBit/s without causing signal degradation.

The CNI 508N2 limits the residual voltage to 40V. This voltage may destroy your precious accessories. The SPN 508N1 with its low protection level 10V is therefore the ideal protection for all other tests with high voltage.



TECHNICAL DETAILS

CNI 508N2 - COUPLING/DECOUPLING NETWORK FOR SHIELDED AND UNSHIELDED LINES

SURGE TEST MODE

Coupling mode	shielded and unshielded cable with up to 4 pairs
Test voltage	Max. 3kV* (1.2/50us) (* only with connected RJ45 connector; if left open the max. test voltage is limited to 1.5kV)
Residual voltage	Max. 40V @2kV Surge, line - PE

RINGWAVE TEST MODE

Coupling mode	shielded and unshielded cable with up to 4 pairs
Test voltage	Max. 3kV* (0.5us/100kHz) (* only with connected RJ45 connector; if left open the max. test voltage is limited to 1.5kV)
Residual voltage	Max. 40V @2kV Ringwave, line - PE

BURST TEST MODE

Coupling mode	shielded cable with up to 4 pairs
Test voltage	Max. 4kV* (5/50ns) (* only with connected RJ45 connector; if left open the max. test voltage is limited to 1.5kV)
Residual voltage	Max. 40V @2kV Burst, line - PE

TELECOM LINE SPECIFICATIONS

Input/Output	RJ45 female connectors for telecom lines
Terminal layout	Pair 1: pins 1/2 Pair 2: pins 3/6 Pair 3: pins 4/5 Pair 4: pins 7/8
Data rate	up to 1,000MBit/s
Protection	+ - 60V between two pairs
Operating voltage	max. 57VDC
Operating current	max. 1A

INPUTS

Surge/Ringwave shield	SHV connector
Surge/Ringwave unshielded	SHV connector
Burst	SHV connector

GENERAL DATA

Dimensions	270mm x 110mm x 140mm (LxWxH)
Weight	6.5kg
Temperature	5°C - 40°C (operation)
Rel. humidity	10% - 90%, non condensing

OPTION SPN 508N1 - SURGE PROTECTION NETWORK FOR UNSHIELDED AND SHIELDED LINES

SURGE TEST MODE

Number of lines	4 twisted pairs
Max. discharge current	2kA (8/20us) without destruction to the RJ45 contacts
Residual voltage	max. 10V
Insertion loss	< -1.5dB (300kHz - 100MHz)

TELECOM LINE SPECIFICATION

Input/Output	RJ45 female connectors for telecom lines
Terminal layout	Pair 1: pins 1/2 Pair 2: pins 3/6 Pair 3: pins 4/5 Pair 4: pins 7/8
Data rate	up to 1,000MBit/s

GENERAL DATA

Dimensions	115mm x 80mm x 80mm (LxWxH)
Weight	0.7kg
Temperature	5°C - 40°C (operation)
Rel. humidity	10% - 90%, non condensing

COMPETENCE WHEREVER YOU ARE



CONTACT EM TEST DIRECTLY

Switzerland

EM TEST (Switzerland) GmbH > Sternenhofstraße 15 > 4153 Reinach > Switzerland
 Phone +41 (0)61/7179191 > Fax +41 (0)61/7179199
 Internet: www.emtest.ch > E-mail: sales.emtest@ametek.com

Germany

EM TEST GmbH > Lünener Straße 211 > 59174 Kamen > Deutschland
 Phone +49 (0)2307/26070-0 > Fax +49 (0)2307/17050
 Internet: www.emtest.com > E-mail: info.emtest@ametek.de

France

EM TEST FRANCE > Le Trident - Parc des Collines > Immeuble B1 - Etage 3 > 36, rue Paul Cézanne > 68200 Mulhouse > France
 Phone +33 (0)389 31 23 50 > Fax +33 (0)389 31 23 55
 Internet: www.emtest.fr > E-mail: info@emtest.fr

Poland

EM TEST Polska > ul. Ogrodowa 31/35, 00-893 Warszawa > Polska
 Phone +48 (0)518 64 35 12
 Internet: www.emtest.com/pl > E-mail: info_polska.emtest@ametek.de

USA / Canada

EM TEST USA > 9250 Brown Deer Road > San Diego > CA 92121
 Phone +1 (858) 699 1685 > Fax +1 (858) 458 0267
 Internet: www.emtest.com > E-mail: sales.emtest@ametek.com

P.R. China

E & S Test Technology Limited > Rm 913, Leftbank > No. 68 Bei Si Huan Xi Lu > Haidian District > Beijing 100080 > P.R. China
 Phone +86 (0)10 82 67 60 27 > Fax +86 (0)10 82 67 62 38
 Internet: www.emtest.com > E-mail: info@emtest.com.cn

Republic of Korea

EM TEST Korea Limited > #405 > WooYeon Plaza > #986-8 > YoungDeok-dong > Giheung-gu > Yongin-si > Gyeonggi-do > Korea
 Phone +82 (31) 216 8616 > Fax +82 (31) 216 8616
 Internet: www.emtest.co.kr > E-mail: sales@emtest.co.kr

Information about scope of delivery, visual design and technical data correspond with the state of development at time of release. Technical data subject to change without further notice.