

EMF Measurement Broadband E-Field Monitoring Systems for EMC

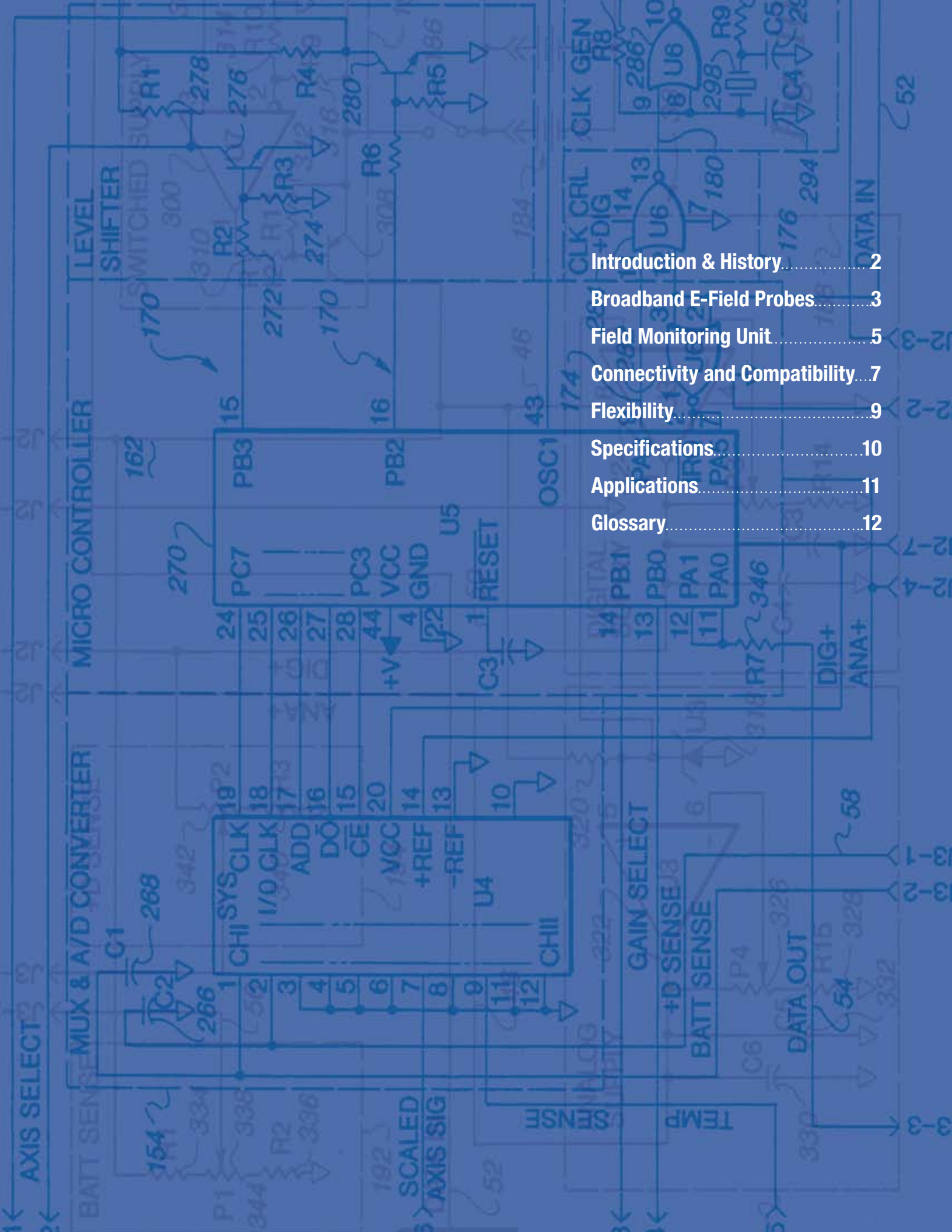

Enabling Your Success™

 **ETS-LINDGREN™**
An ESCO Technologies Company



Introduction & History.....	2
Broadband E-Field Probes.....	3
Field Monitoring Unit.....	5
Connectivity and Compatibility.....	7
Flexibility.....	9
Specifications.....	10
Applications.....	11
Glossary.....	12

Where It All Began

Holiday Industries (an integral part of ETS-Lindgren) has a long history of innovation in the design of EMF sensors. More than 30 years and thousands of probes later, our HI Series probes are still leading the way with improvements and product introductions that set the standard for the industry.

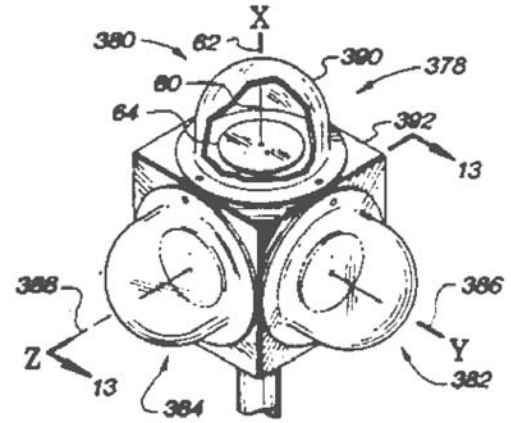

Broadband Frequency Meter Probe

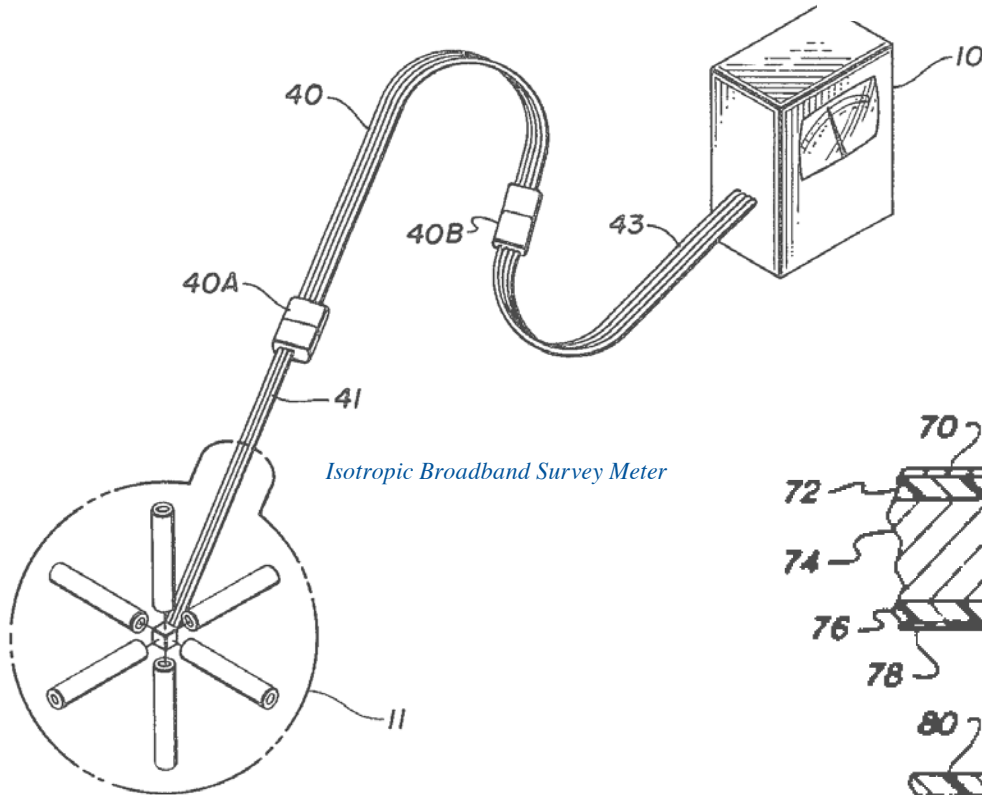

Isotropic Broadband Survey Meter

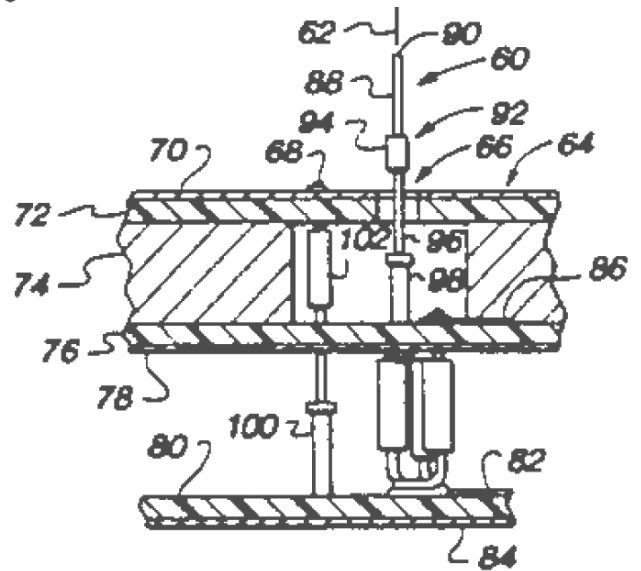

Broadband Frequency Meter Probe

<p>1970's Introduced Survey Probes for Testing Microwave Ovens</p>	<p>1982 Received US Patent 4,365,192 for an Isotropic Broadband Survey Meter</p>	<p>1991 Received US Patent 5,057,848 for a Broadband Frequency Meter Probe</p>	<p>2001 Received US Patent 6,564,158,B1 for a Tri-axial Sensor Assembly</p>
---	---	---	--

Meet Today's RF Immunity Standards and Tomorrow's Challenges

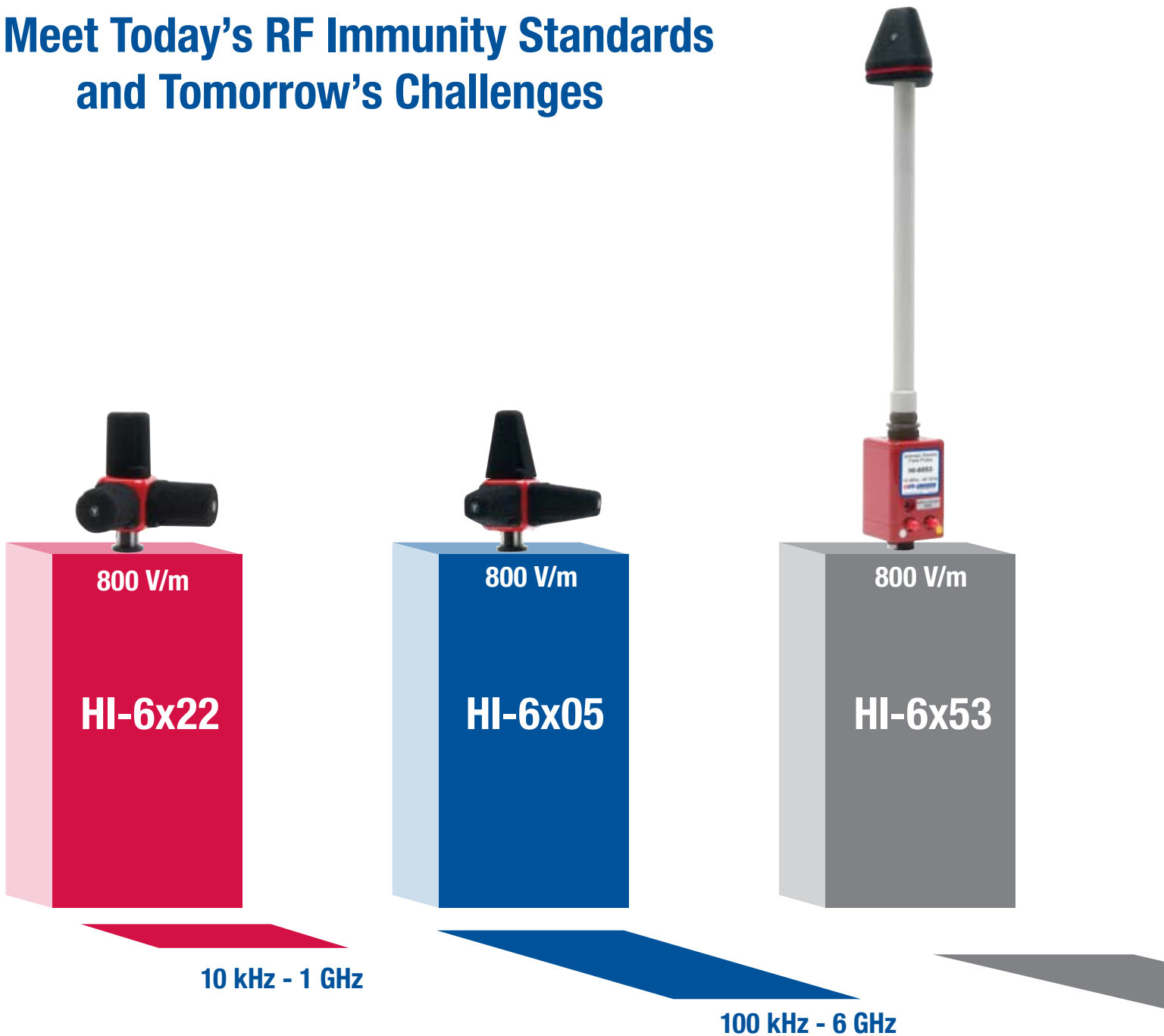

The probes shown above are available in either laser (HI-61xx) or battery-powered (HI-60xx) versions. Both versions use the same sensor circuitry and have the same specifications for frequency response and dynamic range, linearity and isotropy.

Laser-powered probes are ideal for fixed-site, time extended measurements. Battery-powered probes are ideal when portability is required and tests do not exceed a typical test day. Both versions are compatible with our HI-6100 Field Monitor.

ETS-Lindgren's HI Series of Broadband E-field probes meet or exceed the requirements of today's automotive, MIL-STD and commercial EMC RF immunity standards. Their higher levels of performance meet today's test requirements as well as tomorrow's challenges.

To reduce cost and complexity, our probe series was designed to cover a broad frequency and dynamic range with just three models:

HI-6x22 probes are designed to provide the best low frequency measurement performance of any probe in this series. Response at low frequency remains accurate and predictable regardless of field intensity variations.

HI-6x05 probes are the "work horses" of the series. They are designed to offer superior mid-range performance in the frequency bands specified by most EMC immunity test standards.

HI-6x53 probes achieve superior high-frequency response characteristics with the use of concentrically positioned sensors placed in isolation from the electronics module. This probe offers the highest-operating frequency range of any laser probe currently available.



10 MHz - 40 GHz

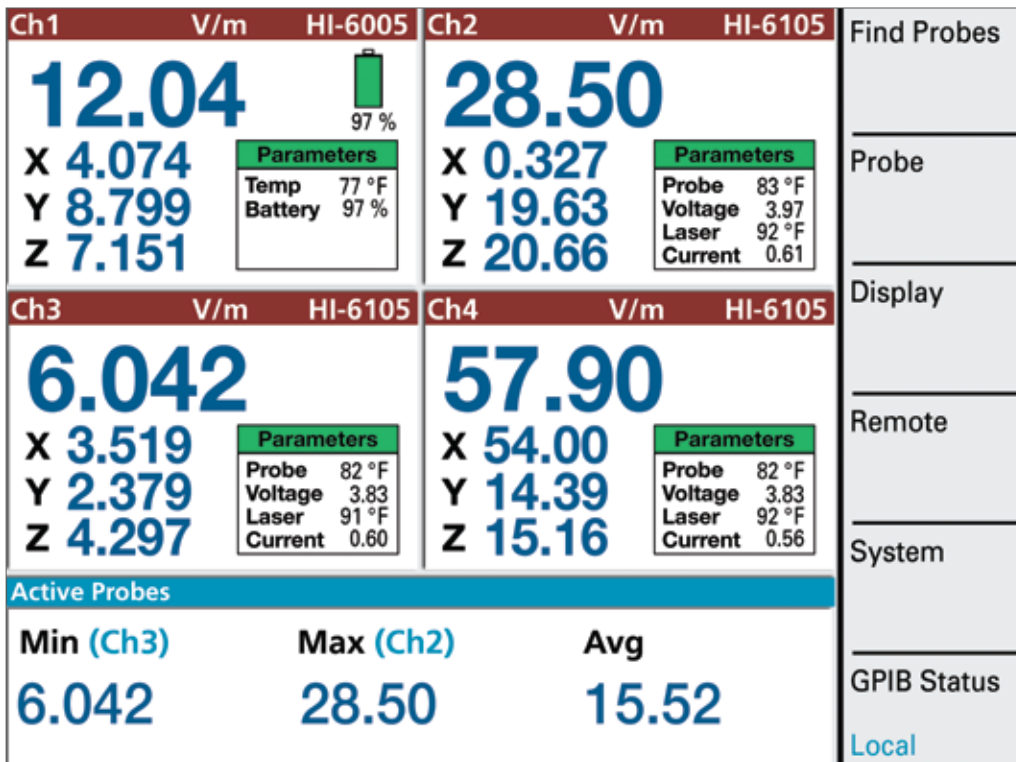

LCD shown actual size, 13.5 cm x 10 cm



Easy to See the Big Picture

Our HI-6100 Field Monitor has the largest color LCD display of any field monitor today. That's an important plus when you're looking at test results for hours at a time or need to see values from across the room.

Easy to See: Our color LCD's display area is a jumbo 13.5 cm x 10 cm. The large size lets you display and read information for up to four probes at once.

Easy to Read: A wide viewing angle means you don't have to be standing in front of the display to read it. Characters remain in sharp contrast at all times.

Easy to Use: All controls are on the front panel. Dynamic menus expand selection choices with the press of a function key. You see information displayed plainly – no cryptic codes or strange symbols.

Easy to Follow Menu Structure

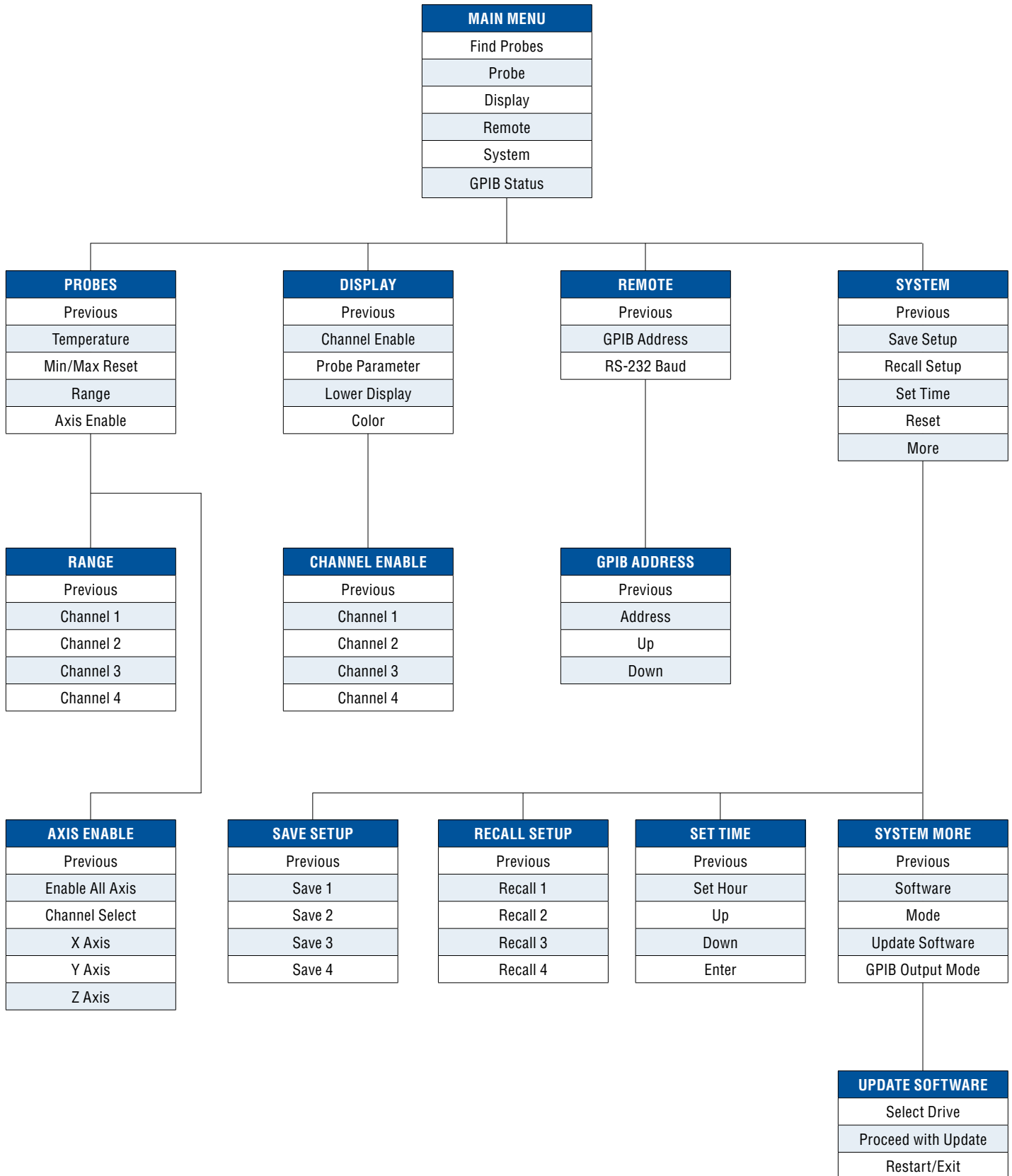

1+ 1+ 1+ 1+ = 3U



Shown with optional benchtop case

Control Up to Four Probes in a Single 3U High Console

Our HI-6100 Field Monitor can be populated with the interface modules needed for any combination of up to four laser and/or battery-powered probes and/or legacy probes. You don't need to add any external rack-mount modules or dangling power cords and connector cables to make everything work. At only 3U high, our Field Monitor slides into the standard 19-inch equipment rack and saves room for your other instrumentation.

Mix and Match Laser, Battery and Legacy Probes with our HI-6100 Field Monitor

Our HI-6100 Field Monitor provides measurement display, control and communications for up to four HI Series probes in any mix-or-match combination. New laser-powered probes can be combined with battery-powered probes and even older legacy probes. Thousands of existing FP and HI Series legacy probes can use the HI-6100 as replacement for the classic FM5004 Field Monitor. With the HI-6100, you get new features such as: a bright 13.5 cm x 10 cm backlit LCD color display; I/O that includes IEEE-488, RS-232 and USB connections; and user definable menus with intuitive control functions. And your existing FM5004 software is compatible with the HI-6100's command set. Just add an optional interface module for your probe to the HI-6100's chassis and start making measurements.



Probe Compatibility

Laser-powered Probes

HI-6122	Yes
HI-6105	Yes
HI-6153	Yes

Battery-powered Probes

HI-6022	Yes
HI-6005	Yes
HI-6053	Yes

Legacy Battery-powered Probes

HI-4xxx	Yes
FP2xxx	Yes
FP4xxx	Yes
FP5xxx	Yes
FP6001	Yes



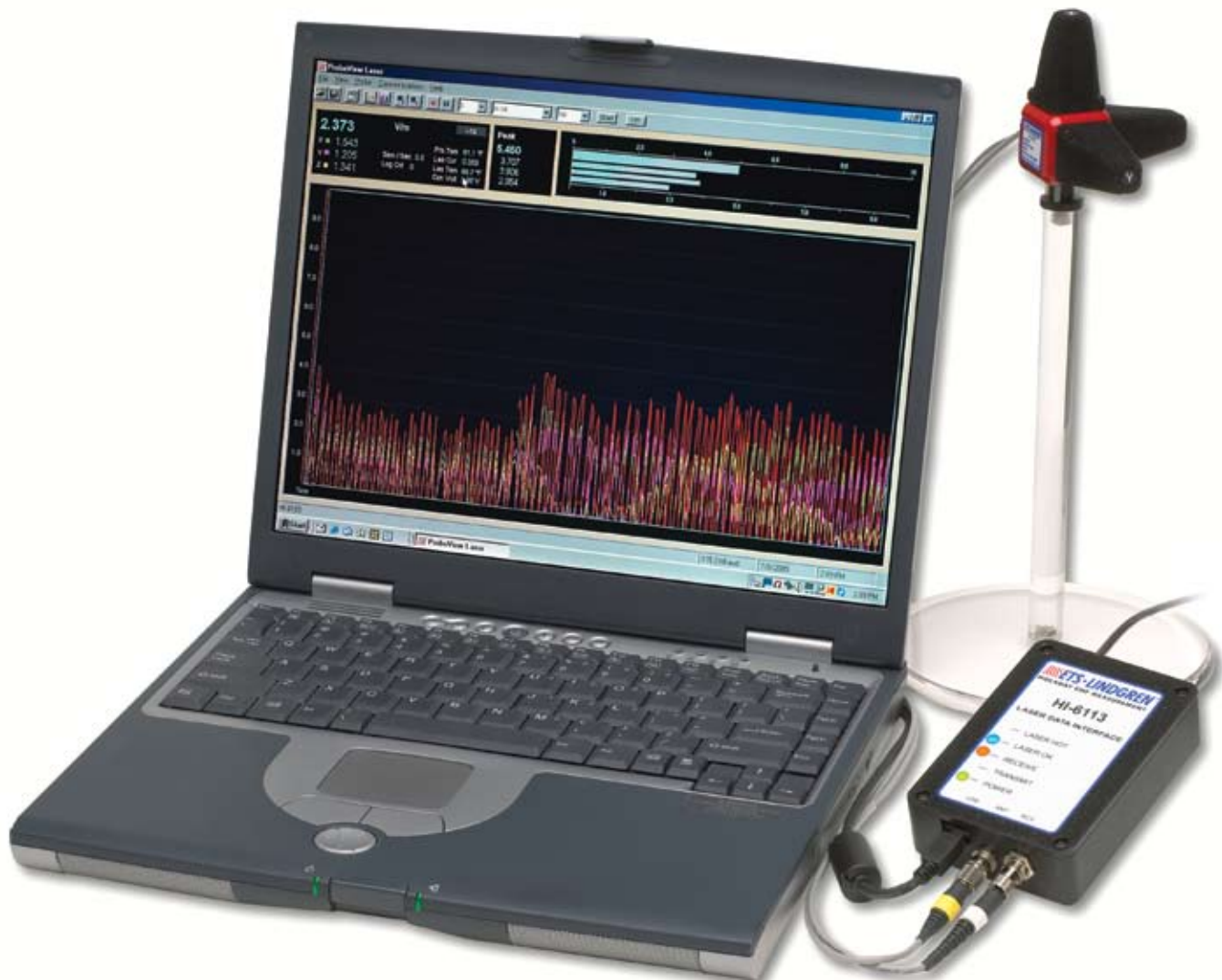

Use Your PC for “Look-and-Log” Probe Measurements

Now you can use your PC to make basic measurements and log the data. Our Data Interface modules and ProbeView™ software are ideal when you don't need the capabilities of our HI-6100 Field Monitor and just need to view and record data measurements.

Two interface modules are offered:

HI-6113 Data Interface connects any of our laser-powered probes (HI-6122, 6105 or 6153) to your PC

via the PC's USB port. The HI-6113 Data Interface includes a wall-plug power supply.

HI-4413P Data Interface connects any of our battery-powered probes (HI-60xx, HI-44xx, FPxxxx) to your PC via the PC's RS-232 port. No external power supply for the Data Interface is required. This means your portable battery-powered laptop PC can be used to make and record remote in-the-field measurements.



PROBES			
	HI-6x22	HI-6x05	HI-6x53
Sensor Type	Electric (E) field	Electric (E) field	Electric (E) field
Frequency Range	10 kHz - 1 GHz	100 kHz - 6 GHz	10 MHz - 40 GHz
Typical Frequency Response	10 kHz - 30 kHz -2.5/+0.5 dB	26 MHz - 2 GHz ± 1 dB	10 MHz - 18 GHz ± 2.5 dB
	30 kHz - 1 GHz ± 1 dB	2 GHz - 4 GHz ± 2 dB	18 GHz - 40 GHz +2 dB/-4 dB
		4 GHz - 6 GHz ± 3 dB	
Isotropicity @ 400 MHz	± 0.5 dB typical	± 0.5 dB typical	± 1.0 dB typical
Sensitivity	2 - 800 V/m single range	0.5 - 800 V/m single range	2 - 800 V/m single range
Linearity	± 0.5 dB of reading	± 0.5 dB of reading	± 0.5 dB of reading
Sampling Rate	70 samples/second max.	70 samples/second max.	70 samples/second max.
Overload Withstand	1,500 V/m CW	1,500 V/m CW	1,500 V/m CW
Power Source 61xx	Laser-powered	Laser-powered	Laser-powered
Power Source 60xx	NiMH rechargeable. Operates up to 10 hrs.	NiMH rechargeable. Operates up to 10 hrs.	NiMH rechargeable. Operates > than 30 hrs.
Dimensions	3.2 x 3.2 x 3.2 cm housing (1.26 x 1.26 x 1.26 in)	3.2 x 3.2 x 3.2 cm housing (1.26 x 1.26 x 1.26 in)	10.2 cm (4.0 in) sensor 43.8 cm (17.25 in) length
	4.3 cm (1.69 in) sensor cap (3)	4.3 cm (1.69 in) sensor cap (3)	
Weight	80 g (2.8 oz)	80 g (2.8 oz)	530 g (18.6 oz)
Operating Temp. Range	10°C - 40°C (50°F - 104°F)	10°C - 40°C (50°F - 104°F)	10°C - 40°C (50°F - 104°F)



FIELD MONITOR & INTERFACE MODULES			
	HI-6100 Field Monitor*	HI-6113 Interface Module*	HI-4413P Interface Module
Display	13.5 cm x 10 cm Color LCD	User supplied PC w/ ProbeView™ software	User supplied PC w/ ProbeView™ software
Probe Input(s)	Four (4) HI-6xxx &/or HI-44xx &/or FPxxxx (any mix) Each probe requires optional Data Module installed in Field Monitor chassis	One (1) HI-6122, HI-6105 or HI-6153	One (1) HI-60xx &/or HI-44xx &/or FPxxxx
Data I/O	IEEE-488, RS-232, USB	USB	RS-232
Power Supply	90 - 260 VAC, 50/60 Hz	90 - 260 VAC, 50/60 Hz	Not Applicable
Width	48.3 cm (19 in)	7.6 cm (3.0 in)	1.3 cm (0.5 in)
Height	13.5 cm (5.3 in)/3U	3.2 cm (1.25 in)	3.2 cm (1.25 in)
Depth	36 cm (14.2 in)	10.2 cm (4.0 in)	6.4 cm (2.5 in)
Weight	5.9 kg (13 lb)	0.55 kg (1.21 lb)	0.14 kg (0.3 lb)
Operating Temp. Range	10°C - 40°C (50°F - 104°F)	10°C - 40°C (50°F - 104°F)	10°C - 40°C (50°F - 104°F)



PROBE COMPATIBILITY				
	HI-6100 Field Monitor	HI-6113 Data Interface	HI-4413P Data Interface	FM5004 Field Monitor
Laser-powered				
HI-6122	x	x		
HI-6105	x	x		
HI-6153	x	x		
Battery-powered				
HI-6022	x		x	x
HI-6005	x		x	x
HI-6053	x		x	x
Legacy Probes (Battery-powered)				
FP2xxx	x		x	x
FP4xxx	x		x	x
FP5xxx	x		x	x
HI-44xx	x		x	x
FP6001	x		x	x

*IEC Class 1M and CDRH Class 1 complaint

Broadband E-Field probes are most commonly associated with electromagnetic compatibility (EMC) radiated immunity (RI) test measurements. The probes are used to establish pre-calibrated fields in an anechoic chamber (Substitution Method) and to monitor delivered fields during immunity/susceptibility testing (Real-time Method). Standards that call for these methods include:

IEC Generic and Product Standards

IEC61000-4-3 Third Addition 2006-02 applies to many product groups including medical, industrial, IT and general electronics. The standard specifies a frequency band of 26 MHz to 6 GHz. Test levels range from 3 V/m to 20 V/m depending on the specific product being tested. Using an isotropic field probe, the test levels are determined across a pre-calibrated uniform field grid of 16 points within a 1.5 meter by 1.5 meter plane. The test facility can be a full or semi-anechoic chamber but must include the absorber placed on the ground plane between the generating antenna and the probe.

Military and Aerospace Immunity Standards

MIL-STD 461F and DO 160E use active leveling and real-time methods during radiated immunity testing. The frequency band ranges from 10 kHz to 40 GHz.

Test levels range 20 V/m to 800 V/m. A partially lined anechoic chamber is used for both MIL-STD 461F and DO 160E testing. Most tests are made on an electrically conductive tabletop with a field probe placed within the illuminated test area. Larger test facilities are required for floor-mounted and full-device testing.

Automotive Immunity Standards

Automotive standards are a mix of industry standards and standards developed internally by manufacturers. They include both pre-calibrated and active-field leveling. The frequency band ranges from 10 kHz to 18 GHz. Test levels range up to 800 V/m. Testing can be at component, subassembly or full vehicle levels, in either test cells or large chambers.

Secondary applications include various human exposure standards as provided by the IEEE, ICNIRP, OSHA and FCC.



Our optional probe stand provides accurate positioning during test procedures.

GLOSSARY

Frequency Range – The range of frequencies the probe will measure within a specified tolerance or frequency response. Probes typically exhibit reduced performance at the extremes of the frequency range. They do not respond as well at the lowest and highest frequencies.

Dynamic Range – The lowest and highest field intensities that the probe will accurately measure. This is usually limited by the linearity specification. Dynamic ranges are typically reported in V/m (volts/meter) or dB (decibel).

Frequency and dynamic range are the primary criteria for matching a probe to an application.

Isotropy – A measure of how accurately the probe will respond to variance in field polarization, incident angle and direction. Isotropic probes sense fields by three mutually-perpendicular (orthogonal) sensors (represented by X, Y and Z axes). Each sensor measures the field in its polarization. The three signals are summed to provide the resultant or total field. The variation in the ability of this process to measure the actual field introduces some uncertainty. Isotropy is most often specified at a single frequency. The isotropy may vary, especially as the frequency increases.

Linearity – A measure of how accurately the probe responds to variations in field intensity, typically stated in dB. When a probe is calibrated, internal linearity factors are set, allowing the probe to accurately

respond to varying field intensities. The linearity specification describes the uncertainties of the linearity process. The linearity specification applies only to field intensities within the dynamic range of the probe, typically stated in dB.

Field Probe – An electrically small field sensor or set of multiple field sensors with conditioning electronics. A field probe is a minimally perturbing device used for measuring a component of a radio-frequency field in a medium (e.g. air).

Frequency Response – The ability of a probe to accurately measure field intensities over a range of frequencies. Frequency response is typically expressed as accuracy in dB over a specified range of frequencies.

Response Time – The time required for the output of a field probe to reach some specified percentage of the steady-state value after a step change in the applied field. Typically 90% of the steady-state value is assumed. The response time is determined by the analog sensing characteristics of the probe.

Sample Rate – Typically stated as samples per second. The maximum rate at which data can be read from the probe. This is related to the ability of the probe to collect a field value, convert the data to a digital format and transmit the data to the read-out device.

Notes

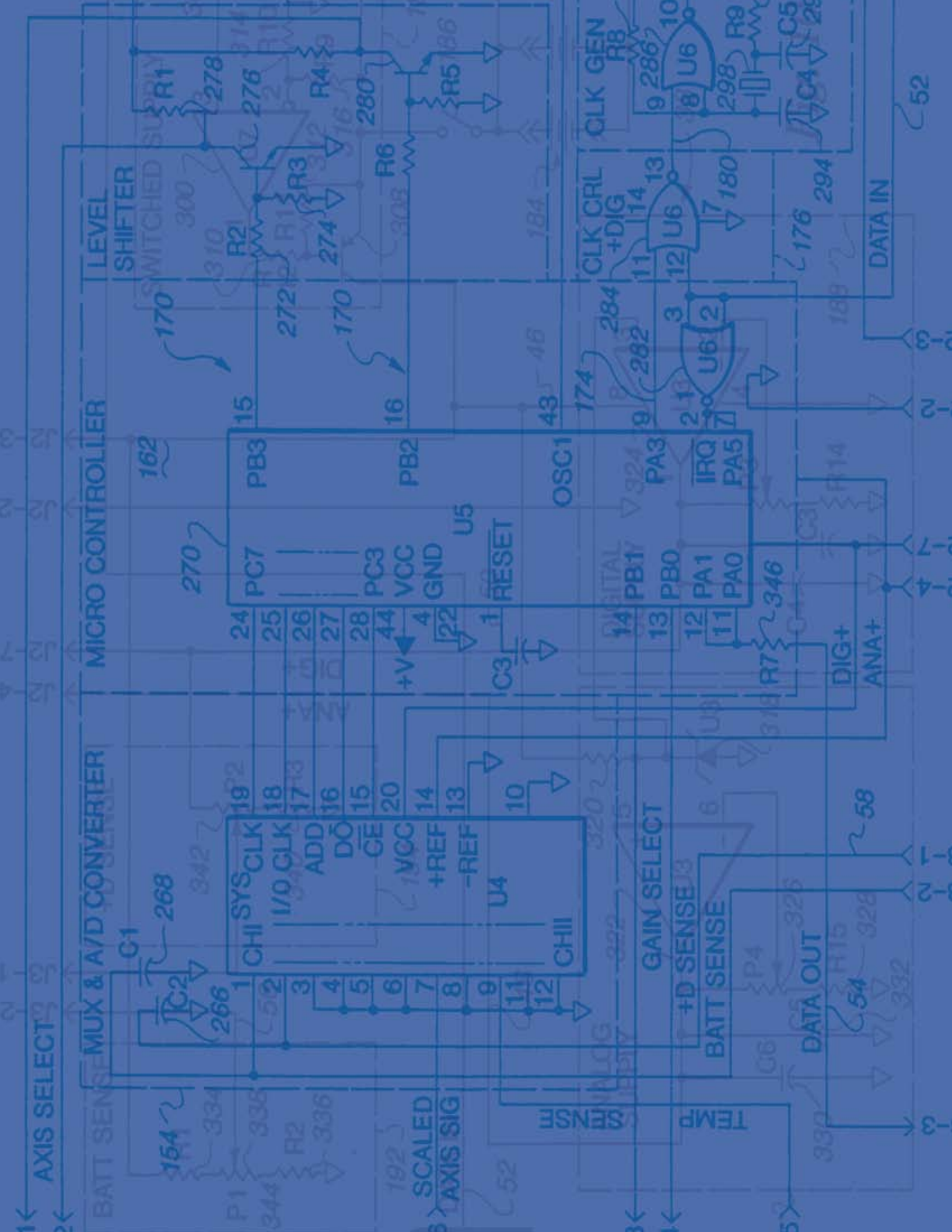



ETS-Lindgren is an international manufacturer of components and systems that detect, measure and manage electromagnetic, magnetic and acoustic energy. The company's products are used for electromagnetic compatibility (EMC), microwave and wireless testing, electromagnetic field (EMF) measurement, radio-frequency (RF) personal-safety monitoring, and control of acoustic environments.

Headquartered in Cedar Park, Texas, ETS-Lindgren has manufacturing facilities in North America, Europe and Asia. The company is a wholly owned subsidiary of ESCO Technologies, a leading supplier of engineered products for growing industrial and commercial markets. ESCO is New York Stock Exchange listed company (symbol ESE) with headquarters in St. Louis, Missouri.



www.ets-lindgren.com

Corporate Headquarters • 1301 Arrow Point Drive • Cedar Park, Texas 78613 • USA
Phone + 1.512.531.6400 • Fax + 1.512.531.6500 • info@ets-lindgren.com

Offices in the US, Finland, UK, France, Singapore, Japan, China, Taiwan