

www.kikusui.co.jp

ELECTRICAL SAFETY TESTERS

Hipot and Insulation Resistance Testers

Hipot Testers

Insulation Resistance Testers

Ground Bond Testers

Leakage Current Testers





Hipot Tester with Insulation Resistance Test

Hipot Tester

High-End

High-performance type suitable for R&D, Quality Assurance, and Automatic Testing Systems

TOS9201 P.4 to 13

ACW 5kV/100mA(500VA)
DCW 6kV/10mA
IR 0.01MΩ – 9.99GΩ (DC25V – 1000V)
    



D 430(16.93")W × 132(5.2")H × 370(14.57")Dmm
W 19kg(41.89 lbs)





TOS9200 P.4 to 13

ACW 5kV/100mA(500VA)
IR 0.01MΩ – 9.99GΩ (DC25V – 1000V)
    



D 430(16.93")W × 132(5.2")H × 370(14.57")Dmm
W 19kg(41.89 lbs)

TOS9213S P.14,15

DCW 10kV/5mA
IR 0.01MΩ – 9.99GΩ (DC25V – 1000V)
   



D 430(16.93")W × 132(5.2")H × 400(15.75")Dmm
W 13kg(41.89 lbs)

TOS9220 P.7 TOS9221

High-voltage scanner (4ch) for TOS9201/9200
 * TOS9221 is equipped with a contact check function





D 430(16.93")W × 88(3.47")H × 370(14.57")Dmm
W 6.5kg(14.33 lbs)

Standard



Standard type suitable for production and inspection lines

TOS5302 P.16 to 21

ACW 5kV/100mA(500VA)
IR 0.03MΩ – 5GΩ (DC25V – 1000V)
  





TOS5301 P.16 to 21

ACW 5kV/100mA(500VA)
DCW 6kV/10mA(50W)
  



TOS5300 P.16 to 21

ACW 5kV/100mA(500VA)
  



TOS8870A P.22 to 24

ACW 5kV/100mA(500VA)
IR 1MΩ – 1000MΩ (DC500V)
 2MΩ – 2000MΩ (DC1000V)



D 430(16.93")W × 132(5.2")H × 370(14.57")Dmm
W 23kg(50.71 lbs)

TOS5101 P.28,29

ACW 10kV/50mA(500VA)
DCW 10kV/5mA



D 430(16.93")W × 177(6.97")H × 370(14.57")Dmm
W 21kg(46.3 lbs)

TOS5051A P.30 to 32

ACW 5kV/100mA(500VA)
DCW 5kV/10mA



D 320(12.6")W × 132(5.2")H × 300(11.81")Dmm
W 16kg(35.27 lbs)

Costsaving

Low-cost type most suitable for plants/factories

TOS8830 P.25 to 27

ACW 4kV/100mA(500VA)
IR 0.50MΩ – 999.9MΩ (DC500V)



D 320(12.6")W × 132(5.2")H × 370(14.57")Dmm
W 21kg(46.3 lbs)and less

TOS8040 P.25 to 27

ACW 4kV/100mA(500VA)



D 320(12.6")W × 132(5.2")H × 370(14.57")Dmm
W 21kg(46.3 lbs)and less

TOS8030 P.25 to 27

ACW 3kV/10mA(30VA) For simplified test



D 160(6.3")W × 132(5.2")H × 230(9.06")Dmm
W 6kg(13.23 lbs)

Insulation Resistance Tester

Ground Bond Tester

Leakage Current Tester

TOS7200 P.35 to 37

IR 0.01MΩ – 5000MΩ (DC25V – 1000V)



D 215(8.47")W × 66(2.6")H × 230(9.06")Dmm
W 2kg(4.41 lbs)

TOS6210 P.38 to 40

0.001Ω – 0.600Ω (6A – 60A)



D 430(16.93")W × 88(3.47")H × 270(10.63")Dmm
W 11kg(24.25 lbs)

TOS6200 P.41,42

0.001Ω – 1.200Ω (3A – 30A)



D 430(16.93")W × 88(3.47")H × 270(10.63")Dmm
W 9kg(19.84 lbs)



TOS3200 P.43 to 45

30μA – 30mA (rms)



D 320(12.6")W × 88(3.47")H × 270(10.63")Dmm
W 5kg(11.02 lbs)

- ACW** Max. output-voltage of AC hipot testing
- DCW** Max. output-voltage of DC hipot testing
- IR** Measurement range of insulation resistance testing
- D** Dimensions
- W** Weight

-  Equipped with rise time control function
-  Equipped with fall time control function
- GPIB** Equipped with GPIB interface as standard
- RS-232C** Equipped with RS-232C interface as standard
- USB** Equipped with USB interface as standard
-  Equipped with timer function

TOS5050A P.30 to 32

ACW 5kV/100mA(500VA)



D 320(12.6")W × 132(5.2")H × 300(11.81")Dmm
W 15kg(33.07 lbs)

TOS5052 P.33,34

ACW 5kV/100mA(500VA)

 * While Supplies Last



D 320(12.6")W × 132(5.2")H × 420(16.54")Dmm
W 22kg(48.5 lbs)

Options

- Remote Control Box
- Test Probe
- Test Lead
- Warning Light Unit
- Buzzer Unit
- Calibrator for a W. Tester
- High-voltage Digital Voltmeter
- Load resistor for calibration of a Hipot Tester



 P.46 to 48

- Data Acquisition Software (for TOS5051A/5050A)



 P.32

The Electrical Appliance & Material Safety Low (Japan), UL (U.S.A.), CSA (Canada), VDE (Germany) and BS (U.K) are some major examples of safety standards in use throughout the world that require the performing of hipot testing. For this reason, it is necessary to confirm for what portion of what standard testing is to be performed when purchasing a hipot tester. Although the 500 VA capacity hipot testers available from KIKUSUI can basically be applied to tests specified in all safety standards, we recommend that you consult with us prior to purchase in order to select the model that best matches your specific application.

For the withstanding test and the insulation resistance test of the EUT (Equipment Under Test) with turned on electricity.

Our Hipot Testers and Insulation Resistance Testers are designed to test the EUT (Equipment Under Test) with turned off electricity. In case the test requires the EUT (Equipment Under Test) with turned on electricity, please contact with our distributor or agent.

TOS9200 SERIES

Hipot Tester with Insulation Resistance Test

Perfect design for System Operation, introducing our top of the line of Hipot / Insulation Resistance Testers



TOS9200(ACW)
TOS9201(ACW/DCW)



Capable of performing hipot and insulation testing in comply with safety standards, including IEC, EN, VDE, BS, UL, CSA, JIS and the Electrical Application and Material Safety Law (Japan)

The TOS9200 Series has been developed to meet a wide diversity of customer needs. Including the refinement and enforcement of Kikusui's former series, its specifications reflect the results of detailed study of our large database of user's requirements including special orders and modifying specifications.

The TOS9200 Series consists of four products : the testers TOS9200 and TOS9201, and the high-voltage scanners TOS9221 and TOS9220.

The TOS9200 is equipped with AC hipot and insulation resistance testing functions, while the TOS9201 has a DC hipot testing function in addition to these two functions. The power block, a core component, employs a high-efficiency switching power supply and a switching amplifier based on PWM systems. These features realize high power and enhanced stability, as well as reducing the size and weight of the unit. When combined with the ground bond tester TOS6200, the TOS9200 Series integrates three or four types of tests in a single process.

Furthermore, when used together with the high-voltage scanner TOS9220/9221 (equipped with a contact check function), the tester is capable of automatically checking test points for up to 16 channels, thereby facilitating a safe, reliable automatic testing system.

- Rise-time control function
- Fall-time control function
- Offset cancel function
- Measured-value hold function
- Output voltage monitoring function
- Memory function
- Program function
- Interlock function
- DC discharge function

TOS9200 SERIES

Hipot Tester with Insulation Resistance Test

Basic performance

Three functions - AC hipot testing, DC hipot testing and insulation resistance testing

The TOS9200 can perform AC hipot tests and insulation resistance tests, while the TOS9201 can also conduct DC withstanding tests. Once connected to a device being tested, the TOS9201 executes an AC hipot test, DC hipot test, and insulation resistance testing in succession in one process.

AC hipot testing at 5 kV and 100 mA

Equipped with a high-efficiency switching power supply in its high-voltage power block, a PWM-based switching amplifier and a 500 VA high-voltage transformer, the TOS9200/TOS9201 realizes a maximum output of 5 kV/100 mA (continuous output for 30 minutes), or 2.5 times the output of Kikusui's former models. At a test voltage of 500 V or more and an upper current of 100 mA, or greater the tester instantaneously satisfies the requirements of a short-circuit current of 200 mA or more which is required by the IEC standard *. In addition, the tester ensures a load effects of 30% or less and the generation of a consistent 50 Hz/60 Hz test voltage free from the affect of the supply voltage. These features eliminate the need to readjust the output voltage once the test voltage is preset.

*Continuous outputs are impossible because the output is cut off if an overcurrent is detected.

DC hipot testing at 6 kV and a maximum output of 50 W

The TOS9201 permits DC hipot testing at up to 6 kV *. The tester is equipped with a stable, low-ripple DC/DC converter with a load factor of 1% or less.

*Maximum output of 50 W for up to 1 minute.

Insulation resistance testing at 25 V to 1000 V and 0.01 MΩ to 9.99 GΩ

The test voltage can be set to 25 V through 1000 V at a resolution of 1 V. Insulation resistance covers a wide measurement range from 0.01 MΩ to 9.99 GΩ *.

Test voltage	Resistance measurement range
25V	0.03 MΩ to 500 MΩ
50V	0.05 MΩ to 1.00 GΩ
100V	0.10 MΩ to 2.00 GΩ
125V	0.13 MΩ to 2.50 GΩ
250V	0.25 MΩ to 5.00 GΩ
500V	0.50 MΩ to 9.99 GΩ
1000V	1.00 MΩ to 9.99 GΩ

A single unit of the TOS9200/9201 is capable of handling

all test voltages required by JIS C 1302 1994 (Insulation Resistor Meter) and fully meets the JIS requirements.

*At a maximum rated current of 1 mA to 50 nA.

Enhanced measurement accuracy

The TOS9200/9201 is provided with a digital voltmeter for hipot testing at an accuracy of $\pm(1\%$ of reading + 30 V) and another one for insulation resistance testing at an accuracy of $\pm(1\%$ of reading + 1 V). Measured values are displayed not only during a test, but while a program is being executed. A digital ammeter with an accuracy of $\pm(3\%$ of reading + 20 μ A) is also provided for hipot testing. Kikusui's predecessors had the highest measurement resolution of about 1 mA, with an accuracy of $\pm 5\%$ of the upper cutoff current when it is set to 100 mA. In contrast, the digital ammeter allows the TOS9200/9201 to make measurements at an accuracy of $\pm(3\%$ of reading + 20 μ A), even if the upper current is set to 100 mA. The ammeter displays measured values while the program executes, as well as during an AC or DC hipot test.

Type	Display accuracy
Voltmeter for hipot testing	$\pm(1\%$ of reading + 30V)
Ammeter for hipot testing	$\pm(3\%$ of reading + 20 μ A)
Voltmeter for insulation resistance testing	$\pm(1\%$ of reading + 1V)
Insulation resistance meter	$\pm(2\%$ of reading)*

*At 1 μ A < measured current \leq 1 mA



TOS9200 SERIES

Hipot Tester with Insulation Resistance Test

Diverse functions

Rise-time control function

In AC hipot testing, DC hipot testing and insulation resistance testing, you can apply a voltage gradually to reach the test voltage, instead of applying the test voltage directly at the start of a test. The voltage increase time can be set to 0.1 s through 99.9 s at a resolution of 0.1 s, and to 100 s to 200 s at a resolution of 1 s. The start voltage is also adjustable between 0% and 99% at a resolution of 1%.

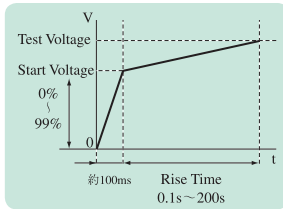

Fall-time control function

In AC hipot testing, you can gradually decrease the test voltage after a PASS judgment. The voltage fall time is adjustable between 0.0 s and 99.9 s at a resolution of 0.1 s, and between 100 s and 200 s at a resolution of 1 s.

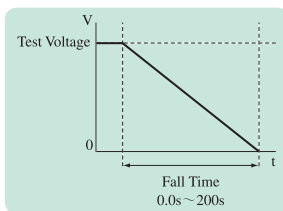

Offset cancel function

In AC hipot tests that require high sensitivity and high voltages, currents flowing into the stray capacity of the test lead wire, jigs, and other components can cause measurement errors. The TOS9200/9201 features a function to cancel these offset currents.

Voltage hold function

During measurement, this function allows you to hold the value of the voltage measured at the end of an AC or DC hipot test, as long as the test results are being displayed. When combined with the rise-time control function, this function enables to observe the insulation breakdown voltage.

Maximum Leakage current and minimum resistance hold function

By selecting “MIN/MAX Mode” in the measurement mode settings, you can hold the maximum current in hipot testing and the minimum resistance after the judgment wait time in insulation resistance testing. These values are shown on the tester’s display. They can also be read back via interface (GPIB or RS-232C).

Output voltage monitoring function

When the output voltage deviates from $\pm(10\%$ of setting + 50 V), the monitoring function activates to suspend the test, thus ensuring highly reliable testing.

Current detection response speed adjustment function

This function switches current detection response speeds for UPPER judgment by adjusting the integrated time constant of the current detection circuit. Three modes are available for the integrated time constant: SLOW (about 40 ms), MID (about 4 ms) and FAST (about 0.4 ms). SLOW mode is used in normal operations. MID and FAST modes are more effective in detecting a discharge occurring instantaneously or containing a large number of frequency components. They are also useful for hipot tests of test devices that insulation likely be breakdown, such as small electronic components.

Memory function

Up to 100 test conditions used in AC and DC hipot testing and insulation resistance testing, such as the test voltage, judgment value and test time, can be stored with a specific name. For instance, you can store the name of an applied safety standard and the destination of the product to be tested. If test conditions are preset, operator can recall relevant test conditions simply by entering the memory number. If you previously assigned a special name to each of these test conditions, operator can check recalled test conditions by name. The memory function allows you to recall test conditions not only through the recall operation on the front panel, but also by remote control.

[Storable test conditions]

	AC withstanding voltage testing	DC withstanding voltage testing	Insulation resistance testing
Test voltage	✓	✓	✓
Test frequency	✓		
Lower cutoff value	✓	✓	✓
ON/OFF of the lower judgment function	✓	✓	✓
Upper cutoff value	✓	✓	✓
ON/OFF of the upper judgment function			✓
ON/OFF of the offset function	✓		
Test time and ON/OFF of the timer function	✓	✓	✓
Start voltage	✓	✓	
Voltage rise time	✓	✓	✓
Voltage fall time	✓		
Judgment wait time		✓	✓
Test voltage range	✓		
SLOW/MID/FAST settings for the response filter	✓		
FLOAT/GND of the LOW terminal	✓	✓	✓
HIGH/LOW/OPEN settings for the scanner channel	✓	✓	✓
ON/OFF of the contact check function	✓	✓	✓

Program function

By coordinating test conditions stored in an AC hipot test, DC hipot test, and insulation resistance test, operator can sequentially run tests that comprise up to 100 steps. When used together with the ground bond tester TOS6200/6210, the TOS9200 Series permits continuous tests combining test conditions stored in the TOS6200, as well as on the TOS9200 itself. Sequential tests are possible, for example, on AC hipot, insulation resistance, DC hipot, and ground bond, in order. The TOS9200 Series stores up to 500 steps and 100 programs, which can be recalled through the recall operation on the front panel or by remote control.

[Sample program]

Step 00		Step 01		Step 02		END
Memory	Interval	Memory	Interval	Memory	Interval	
ACW01	0.2s	DCW01	0.2s	IR01	0.2s	

At Step 00, Step 01 and Step 02, memory ACW01 (AC hipot test), DCW (DC hipot test: TOS9201 only) and IR01 (insulation resistance test) are performed, receptively, in succession at 0.2-second intervals.

TOS9200 SERIES

Hipot Tester with Insulation Resistance Test

Interfaces

REMOTE connector & SIGNAL I/O connector

The REMOTE connector on the front panel is intended exclusively for Kikusui's options (remote control/test probe). It allows start and stop operations by remote control. The SIGNAL I/O connector on the rear panel permits operator to recall panel memory and program memory contents by remote control, as well as controlling start and stop operations. Seven different signals are output from the SIGNAL I/O connector through the open collector.



[SIGNAL I/O]

No.	Signal name	I/O	Details of signal
1	PM0	I	LSB, LSD *1
2	PM1	I	LSD *1
3	PM2	I	LSD *1
4	PM3	I	LSD *1
5	PM4	I	MSD *1
6	PM5	I	MSD *1
7	PM6	I	MSD *1
8	PM7	I	MSB, MSD *1
9	STB	I	Input terminal for the strobe signal of the panel memory and program memory
10	MODE0	I	Selects a test mode *2
11	MODE1	I	Selects a test mode *2
12	N.C		
13	COM		Circuit common (chassis potential)
14	H.V ON	O	ON during a test and an automatic test (AUTO) or while a voltage remains between the output terminals
15	TEST	O	ON during a test (except for voltage rise and voltage fall)
16	PASS	O	ON during the time preset in the PASS HOLD settings when a PASS judgement is made
17	U FAUL	O	Continuously ON in an UPPER FAIL judgement. Continuously ON in a CONTACT FAIL judgement with the scanner connected.
18	L FAUL	O	Continuously ON in an LOWER FAIL judgement. Continuously ON in a CONTACT FAIL judgement with the scanner connected.
19	READY	O	ON during the READY status
20	PROTECTION	O	ON when the PROTECTION function is activated
21	START	I	Input terminal for the START signal
22	STOP	I	Input terminal for the STOP signal
23	ENABLE	I	Input terminal for the ENABLE signal for the START signal
24	+24V		Output terminal for +24 V internal power, with a maximum output current of 100 mA
25	COM		Circuit common (chassis potential)

[Pin Configuration for the SIGNAL I/O Connector]



- Input signal [Low active control input High-level input voltage: 11 V to 15 V / Low-level input voltage: 0 V to 4 V / Low-level input current: Maximum -5 mA / Input interval: Minimum 5 ms]
- Output signal [Open collector output (DC4.5V to 30V) / hipot: DC 30 V / Output saturation voltage : Approximately 1.1 V (25 °C) / Maximum output current : 400 mA (TOTAL)]
- * The input signal circuit is pulled up to +12V. Therefore, opening the input terminal is equivalent to inputting a high-level signal.
- *1 2-digit BCD low active input Signal input terminal for selection between the panel memory for ACW, DCW, and IR, and the program memory for AUTO Memory recall by latching this selection signal at the rise of the strobe signal
- *2 2-bit low active input

Test mode	ACW	DCW	IR	AUTO
MODE0	H	L	H	L
MODE1	H	H	L	L

GPIO/RS-232C interface

A GPIO/RS-232C interface is provided as a standard feature to facilitate the remote control of all functions of the TOS9200/9201 except the POWER switch, the KEYLOCK function, and the program execution (AUTO) function.



RS-232C [Baud rate: 9600/19200/38400 bps/TOS6200/6210 interface (AUTO mode only): START/STOP control, test condition settings, reading of TOS6200/6210 measured values, and measurement results]

GPIO [Remote control of all functions except the POWER switch, the KEYLOCK function, and the program execution (AUTO) function/SH1, AH1, T6, TE0, L4, LE0, SR1, RL1, PP0, DC1, DT0, C0, E1]

Peripheral devices

High-voltage scanner TOS9220/TOS9221

TOS9221 Front View (same for TOS9220)



TOS9221

TOS9220



The high-voltage scanner TOS9220/TOS9221 has a function that distributes the test voltage provided by the TOS9200/9201 to multiple test points. Up to four channels can be used for outputs on this scanner. Each channel can be set to one of the three electric potential modes – HIGH, LOW, or OPEN. Operator can conduct AC/DC hipot and insulation resistance tests on any of the four test points. Furthermore, up to four scanners can be connected to the tester, allowing a maximum of 16 channels. The TOS9200 is equipped with a “contact check function” to check the contact between the output of each channel and a test point. These features ensure highly reliable and labor-saving hipot and insulation resistance tests for electrical and electronic equipment with multiple test points.

*Pictures below are showing rear views of the units with cable clamp of output terminal removed.

TOS9221 Rear View



TOS9220 Rear View

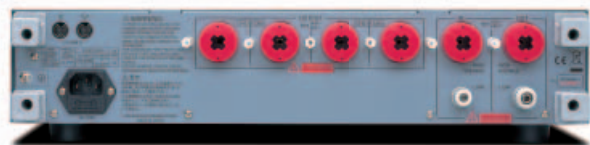

Operation of the high-voltage scanner

On the TOS9200/TOS9201, you can select an electric potential mode for each channel—HIGH(high voltage side), LOW (low voltage side), and OPEN (open mode). The high-voltage scanner permits AC/DC hipot or insulation resistance tests on any of the four test points A to D. For instance, you can set CH1 (test point A) to HIGH, CH2 (test point B) to OPEN, and CH3 (test point C) to LOW, and CH4 (test point D) to LOW. To specify these settings, you can use the TOS9200/9201 panel or the GPIO/RS-232C.

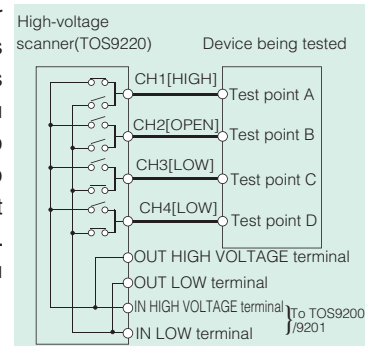

TOS9200 SERIES

Hipot Tester with Insulation Resistance Test

For Stand alone use...

Example of system for applying voltage by Test Lead or start/stop operation by Remote Control Box.

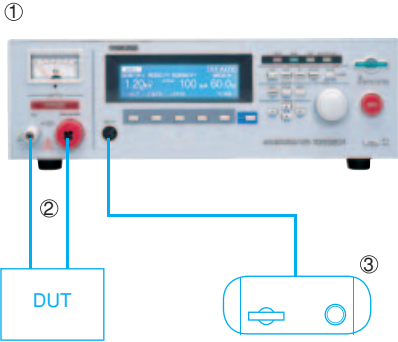

Item	Model	cable length	Required numbers
① Hipot / Insulation Resistance Tester AC/DC	TOS9201		1 pc.
② High-Voltage Test Lead	TL01-TOS	1.5m *1	1 set
③ Remote Control Box	RC01-TOS *2	1.5m	1 pc.

*1: Also available for 3m cable, TL02-TOS

*2: Also available for both-hands operation, RC02-TOS

Example of system for applying voltage or start/stop operation by High-Voltage Test Probe.

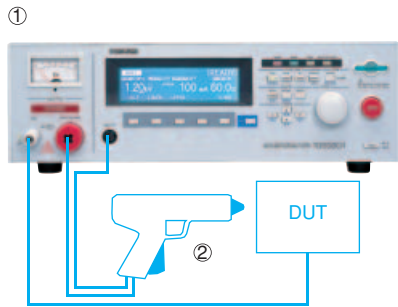

Item	Model	cable length	Required numbers
① Hipot / Insulation Resistance Tester AC/DC	TOS9201		1 pc.
② High-Voltage Test Lead	HP01A-TOS	1.5m *1	1 pc.

*1: Also available for 3m cable, HP02A-TOS

For Multiple Channel Testing by High Voltage Scanner...

Example of system consisting TOS9201 and TOS9221 × 2sets (8CH)

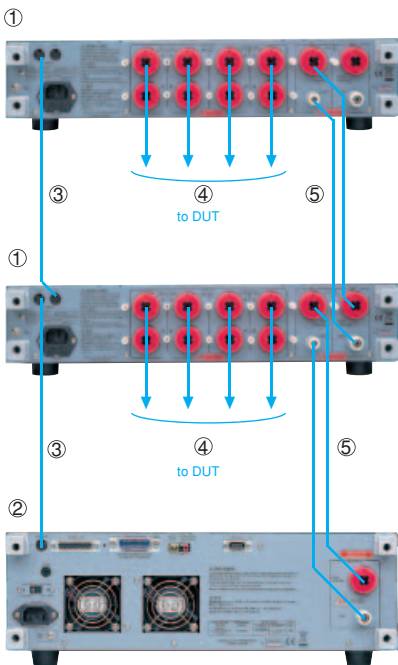

Item	Model	cable length	Required numbers
① High-Voltage Scanner	TOS9221		2 pc.
② Hipot / Insulation Resistance Tester AC/DC	TOS9201		1 pc.
③ Interface cable	85-50-0210	0.5m *1	2 pc.
④ High-Voltage Test Lead (red)	TL07-TOS	1.5m	8 pc.
⑤ High-Voltage Leads for Parallel connection	TL06-TOS	0.5m *2	2 set

*1: If the length of cable is required more than 0.5m , please contact with our local distributor.

*2: Also available for 1.5m cable, TL04-TOS

[Rack mount bracket]

TOS9200 / 9201	(JIS)	KRB150-TOS
	(EIA)	KRB3-TOS
TOS9220 / 9221	(JIS)	KRB100-TOS
	(EIA)	KRB2-TOS

[CAUTION] In case of using more than 2sets of High Voltage Scanner, it is required to rack mount or locate these units to the side of Hipot / Insulation Resistance Tester, and it should not be piled up more than 2sets of High Voltage Scanner units.

TOS9200 SERIES

Hipot Tester with Insulation Resistance Test

Single process to apply until ground bond test---

Example of system consisting TOS9201 and TOS6210

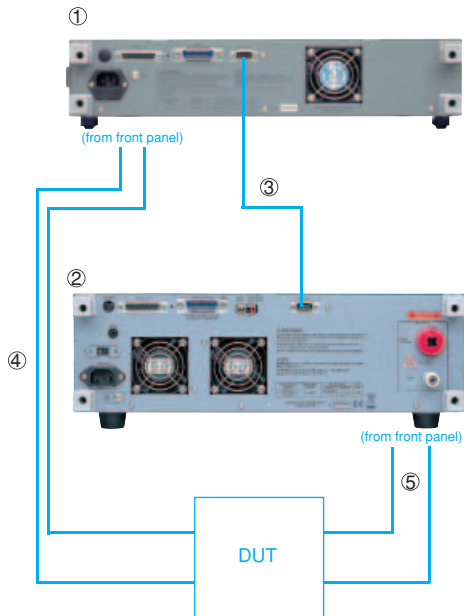

Item	Model	cable length	Required numbers
① Ground Bond Tester	TOS6210		1 pc.
② Hipot / Insulation Resistance Tester AC/DC	TOS9201		1 pc.
③ RS-232C Cross Cable (9pin female-9pin female)			1 pc.
④ Low-Voltage Test Lead	TL12-TOS	1.5m	1 set
⑤ High-Voltage Test Lead	TL01-TOS	1.5m *1	1 set

*1: Also available for 3m cable, TL02-TOS

[Rack mount bracket]

TOS9200 / 9201	(JIS)	KRB150-TOS
	(EIA)	KRB3-TOS
TOS6210 / 6200	(JIS)	KRB100-TOS
	(EIA)	KRB2-TOS

It is capable to perform for hipot / Insulation Resistance and Ground bond testing in one single process by controlling TOS6210 from TOS9201.

Fully Automated System by PC---

Example of system consisting TOS9201, TOS9221 (4CH) and TOS6210

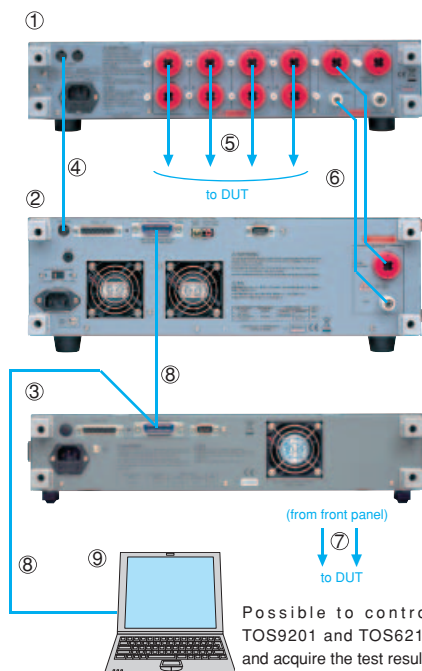

Item	Model	cable length	Required numbers
① High-Voltage Scanner	TOS9221		1 pc.
② Hipot / Insulation Resistance Tester AC/DC	TOS9201		1 pc.
③ Ground Bond Tester	TOS6210		1 pc.
④ Interface cable	85-50-0210	0.5m *1	1 pc.
⑤ High-Voltage Test Lead (red)	TL07-TOS	1.5m	4 pc.
⑥ High-Voltage Leads for Parallel connection	TL06-TOS	0.5m *2	1 set
⑦ Low-Voltage Test Lead	TL12-TOS	1.5m	1 set
⑧ GPIB Cable	408J-102	2m *3	2 pc.
⑨ PC (with GPIB Interface cable)			1 pc.

*1: If the length of cable is required more than 0.5m , please contact with our local distributor.

*2: Also available for 1.5m cable, TL04-TOS

*3: Also available for 1m cable, 408J-101 and 4m cable, 408J-104

[Rack mount bracket]

TOS9200 / 9201	(JIS)	KRB150-TOS
	(EIA)	KRB3-TOS
TOS9220 / 9221 / 6210 / 6200	(JIS)	KRB100-TOS
	(EIA)	KRB2-TOS

[CAUTION] In case of use for combining more than 2sets of High Voltage Scanner unit and Ground Bond Tester, it is required to rack mount or locate these units to the side of Hipot / Insulation Resistance Tester, and it should not be piled up more than 2sets of High Voltage Scanner units.

TOS9200 SERIES

Hipot Tester with Insulation Resistance Test

Hipot Tester

Item	TOS9200	TOS9201		
Output section				
AC	Output-voltage range	0.05 kV to 5.00 kV AC		
	Resolution	10 V		
	Accuracy	±(1.5% of setting + 20 V) [with no load]		
	Maximum rated load (*1)	500 VA (5 kV/100 mA)		
	Maximum rated current	100 mA [output voltage of 0.2 kV or more]		
	Transformer capacity	500 VA		
	Output-voltage waveform(*2)	Sine wave		
	Distortion	2% or less [with no load or pure resistive load at output voltage of 0.5 kV or more applied]		
	Frequency	50 Hz/60 Hz		
	Accuracy	±0.1%		
	Voltage regulation	±3% or less [maximum rated load → no load]		
	Short-circuit current	200 mA or more, 350 mA or less [at output voltage of 0.5 kV or more]		
	Type of output	PWM switching		
DC	Output-voltage range	0.05 kV to 6.00 kV DC		
	Resolution	10 V		
	Accuracy	±(1.5% of the setting + 20 V)		
	Maximum rated load (*1)	50 W (5 kV/10 mA)		
	Maximum rated current	10 mA		
	Ripple	No load at 5 kV	50 Vp-p Typ.	
		Maximum rated load	150 Vp-p Typ.	
	Voltage regulation	1% or less [maximum rated load → no load]		
	Short-circuit current	40 mA Typ.		
Discharge function	Forced discharge at the end of test(discharge resistance: 125 kΩ)			
Start voltage	The voltage at the start of the test can be set as the start voltage.			
Setting range	0% to 99% of the test voltage (resolution of 1%)			
Output-voltage monitoring function	If the output voltage exceeds ±(10% of the setting + 50 V), output is cut off and the protection function activates.			
Voltmeter				
Analog	Scale	6 kV AC/DC F.S		
	Accuracy	±5% F.S		
	Indicator	Mean-value responsive/root-mean-square value scale		
Digital	Measurement range	0.0 kV to 6.00 kV AC/DC		
	Resolution	10 V		
	Accuracy	±(1.0% of the reading + 30 V)		
	Response	Mean-value responsive/root-mean-square value display (response time of 200 ms)		
	HOLD function	The voltage measured at the end of test is held during the PASS and FAIL judgment time period.		

*1 Time limitation on output

The tester's hipot generator is designed to radiate half as much heat as the rated output, in consideration of the size, weight, cost, and other factors of the tester. It is therefore necessary to use the tester within the ranges specified below. Operations deviating from these ranges may heat the output section excessively, thereby activating the protective circuit. In such a case, suspend the test and wait until the temperature falls to the normal level.

[Output limitation in hipot testing (Output time = voltage rise time + test time + voltage fall time)]

Ambient temperature	Upper current	Pause Time	Output time
t ≤ 40 °C	AC	50 < i ≤ 110 mA	At least as long as the output time
		i ≤ 50 mA	Not necessary
	DC	5 < i ≤ 11 mA	At least as long as the output time
		i ≤ 5 mA	At least as long as the judgement wait time (WAIT TIME)

*2 Test-voltage waveform

When an AC test voltage is applied to a capacitive load, it is possible that the voltage becomes higher even than that when in the no load state. Furthermore, waveform distortion also may occur if the capacitance of the load is voltage-dependent (such as of ceramics capacitors). When the test voltage is not higher than 1.5 kV and the capacitance is not larger than 1000 pF, such test voltage changes are only of negligible levels. As the output type of the high-voltage generator block of the tester is PWM switching, switching noise and spike noise that the test voltage includes increase when the test voltage is 500 V or less. The lower the test voltage is, the more the waveform distortion increases.

Item	TOS9200	TOS9201								
Ammeter(*3)										
Measurement range	0.00 mA to 110 mA AC	0.00 mA to 110 mA AC/0.00 mA to 11 mA DC								
Display	<table border="1"> <tr> <td>i < 1 mA</td> <td>1 mA ≤ i < 10 mA</td> <td>10 mA ≤ i < 100 mA</td> <td>100 mA ≤ i</td> </tr> <tr> <td>□ □ □ μA</td> <td>□ □ □ mA</td> <td>□ □ □ mA</td> <td>□ □ □ mA</td> </tr> </table>	i < 1 mA	1 mA ≤ i < 10 mA	10 mA ≤ i < 100 mA	100 mA ≤ i	□ □ □ μA	□ □ □ mA	□ □ □ mA	□ □ □ mA	i = measured current
i < 1 mA	1 mA ≤ i < 10 mA	10 mA ≤ i < 100 mA	100 mA ≤ i							
□ □ □ μA	□ □ □ mA	□ □ □ mA	□ □ □ mA							
Accuracy	±(3% of the reading + 20 μA) [after the offset cancel function is activated, if the scanner is mounted]									
Response	Mean-value responsive / root-mean-square value display (response time of 200 ms)									
Hold function	The measured current at the end of the test is held during the PASS judgment time period.									
Offset cancel function	The current flowing to the insulation resistor between the output cables and the stray capacity is cancelled up to 100 μA/kV (in AC hipot testing only).									
Calibration	Performs calibration using the root-mean-square value of a sine wave with a pure resistive load									
Selection of LOW/GUARD for the GND (*4)	Selection permitted for current measurement between the mode for the GND point connected to the LOW terminal, and the mode using guard.									
LOW	Connects the GND point to the LOW terminal. Measures the current flowing to the LOW terminal (chassis) (for normal operation).									
GUARD	Sets the GND point as guard. Measures the current flowing to the LOW terminal, but does not measure the current flowing to the chassis (for high-sensitivity, high-accuracy measurements).									
Time										
Setting range for the voltage rise time (RISE TIME)	0.1 s to 200 s									
Setting range for the voltage fall time (FALL TIME)	0 s to 200 s (Valid only with PASS judgement)	0 s to 200 s (Valid only with PASS judgement in AC hipot testing)								
Setting range for the test time (TEST TIME)	0.3 s to 999 s With the TIMER OFF function									
Setting range for the judgement wait time (WAIT TIME)	0.3 s to 10 s (Only for DC hipot testing)	[RISE TIME + TEST TIME > WAIT TIME]								
Accuracy	± (100 ppm + 20 ms)									

TOS9200 SERIES

Hipot Tester with Insulation Resistance Test

Item	TOS9200	TOS9201																				
Judgement function																						
Judgement method/action	<table border="1"> <thead> <tr> <th>Judgement</th> <th>Judgement method</th> <th>Display</th> <th>Buzzer</th> <th>SIGNAL I/O</th> </tr> </thead> <tbody> <tr> <td>UPPER FAIL</td> <td>When the tester detects a current exceeding the upper current, it cuts off the output and makes an UPPER FAIL judgement. In DC hipot testing, however, no judgement is made until the judgement wait time (WIT TIME) has elapsed.</td> <td>The FAIL LED lights up. Displayed on the LCD</td> <td>ON</td> <td>Outputs the U FAIL signal</td> </tr> <tr> <td>LOWER FAIL</td> <td>When the tester detects a current below the lower current, it cuts off the output and makes a LOWER FAIL judgement. However, no judgement is made during the voltage rise time (RISE TIME) or voltage fall time (FALL TIME) in AC hipot testing.</td> <td>The FAIL LED lights up. Displayed on the LCD</td> <td>ON</td> <td>Outputs the L FAIL signal</td> </tr> <tr> <td>PASS</td> <td>When the preset time has elapsed without any abnormalities, the tester cuts off the output and makes a PASS judgement.</td> <td>The PASS LED lights up. Displayed on the LCD</td> <td>ON</td> <td>Outputs the PASS signal</td> </tr> </tbody> </table>	Judgement	Judgement method	Display	Buzzer	SIGNAL I/O	UPPER FAIL	When the tester detects a current exceeding the upper current, it cuts off the output and makes an UPPER FAIL judgement. In DC hipot testing, however, no judgement is made until the judgement wait time (WIT TIME) has elapsed.	The FAIL LED lights up. Displayed on the LCD	ON	Outputs the U FAIL signal	LOWER FAIL	When the tester detects a current below the lower current, it cuts off the output and makes a LOWER FAIL judgement. However, no judgement is made during the voltage rise time (RISE TIME) or voltage fall time (FALL TIME) in AC hipot testing.	The FAIL LED lights up. Displayed on the LCD	ON	Outputs the L FAIL signal	PASS	When the preset time has elapsed without any abnormalities, the tester cuts off the output and makes a PASS judgement.	The PASS LED lights up. Displayed on the LCD	ON	Outputs the PASS signal	
Judgement	Judgement method	Display	Buzzer	SIGNAL I/O																		
UPPER FAIL	When the tester detects a current exceeding the upper current, it cuts off the output and makes an UPPER FAIL judgement. In DC hipot testing, however, no judgement is made until the judgement wait time (WIT TIME) has elapsed.	The FAIL LED lights up. Displayed on the LCD	ON	Outputs the U FAIL signal																		
LOWER FAIL	When the tester detects a current below the lower current, it cuts off the output and makes a LOWER FAIL judgement. However, no judgement is made during the voltage rise time (RISE TIME) or voltage fall time (FALL TIME) in AC hipot testing.	The FAIL LED lights up. Displayed on the LCD	ON	Outputs the L FAIL signal																		
PASS	When the preset time has elapsed without any abnormalities, the tester cuts off the output and makes a PASS judgement.	The PASS LED lights up. Displayed on the LCD	ON	Outputs the PASS signal																		
	<ul style="list-style-type: none"> The PASS signal is output at the timing preset on PASS HOLD. If HOLD is set, the PASS signal is output continuously until the STOP signal is input. The UPPER FAIL signal and the LOWER FAIL signal are output continuously until the STOP signal is input. The FAIL and PASS buzzer volumes are adjustable. However, they cannot be adjusted individually, as they are set in common. 																					
Setting range for the upper current (UPPER)	0.01 mA to 110 mA AC		0.01 mA to 110 mA AC / 0.01 mA to 11 mA DC																			
Setting range for the lower current (LOWER)	0.01 mA to 110 mA AC (With the LOWER OFF function)		0.01 mA to 110 mA AC / 0.01 mA to 11 mA DC (With the LOWER OFF function)																			
Judgement accuracy (*3)	±(3% of setting + 20 µA) [After the offset cancel function is activated, if the scanner is mounted]																					
Current detection method	The absolute current values are integrated and compared with the reference value.																					
Response-speed switching function	The current-detection response speed for UPPER FAIL judgement can be set to FAST/MID/SLOW (for AC hipot testing only).																					

*3 In AC hipot testing, a current flows into the stray capacity of measurement leadwire and fixtures. When the optional high-voltage scanner TOS9220/9221 is used, a current of approximately 22 µA/kV flows into the stray capacity of each scanner. The table below shows the approximate currents flowing into such stray capacity. When the LOW terminal is set to GND, a current flowing into the stray capacity is added for measurement purposes to the current flowing into the DUT. In particular, for high-sensitivity, high-accuracy judgement, it is necessary to add the current flowing into the stray capacity to the lower/upper current. When the LOW terminal is set to FLOAT, the effect of the current flowing into the stray capacity is negligible. If the offset cancel function is used, the current flowing into the stray capacity can be eliminated from the measurement.

Output voltage	1kV	2kV	3kV	4kV	5kV
Hanging a 350-mm test lead wire (Typ. value)	2 µA	4 µA	6 µA	8 µA	10 µA
Using the accessory leadwire TL01-TOS (Typ. value)	16 µA	32 µA	48 µA	64 µA	80 µA
High-voltage scanner (Typ. value, not including the test leadwire)	22 µA	44 µA	66 µA	88 µA	110 µA

*4 With the GND set to GUARD, current measurement is disabled if the part of the DUT connected to the LOW terminal is grounded, which poses extreme danger. Never ground the DUT. In ordinary operation, set the GND to LOW.

Insulation Resistance Tester

Item	TOS9200	TOS9201								
Output section										
Output-voltage range	-25 V to -1000 V DC									
Resolution	1 V									
Setting accuracy	±(1.5 % of Setting + 2 V)									
Maximum rated load	1 W (-1000 V DC/1 mA)									
Maximum rated current	1 mA									
Ripple	2 Vp-p or less									
1 kV no-load	10 Vp-p or less									
Maximum rated load	10 Vp-p or less									
Voltage regulation	1% or less [Maximum rated load → no load]									
Short-circuit current	12 mA or less									
Discharge function	Forced discharge at the end of test (discharge resistance : 25 kΩ)									
Output-voltage monitoring function	If the output voltage exceeds ±(10% of the setting + 50 V), output is cut off and the protection function activates.									
Voltmeter										
Analog	Scale	6 kV AC/DC F.S								
	Accuracy	±5% F.S								
	Indicator	Mean-value responsive / root-mean-square value scale								
Digital	Measurement range	0 V to -1200 V								
	Resolution	1 V								
	Accuracy	±(1 % of reading + 1 V)								
Resistance meter										
Measurement range	0.01 MΩ - 9.99 GΩ (Within the maximum rated current range of 1 mA to 50 nA)									
Display	<table border="1"> <thead> <tr> <th>R < 10.0 MΩ</th> <th>10.0MΩ ≤ R < 100.0MΩ</th> <th>100.0MΩ ≤ R < 1.00GΩ</th> <th>1.00GΩ ≤ R ≤ 9.99GΩ</th> </tr> </thead> <tbody> <tr> <td>□.□ □ MΩ</td> <td>□ □.□ MΩ</td> <td>□ □ □ MΩ</td> <td>□.□ □ GΩ</td> </tr> </tbody> </table>	R < 10.0 MΩ	10.0MΩ ≤ R < 100.0MΩ	100.0MΩ ≤ R < 1.00GΩ	1.00GΩ ≤ R ≤ 9.99GΩ	□.□ □ MΩ	□ □.□ MΩ	□ □ □ MΩ	□.□ □ GΩ	R = measured insulation resistance
R < 10.0 MΩ	10.0MΩ ≤ R < 100.0MΩ	100.0MΩ ≤ R < 1.00GΩ	1.00GΩ ≤ R ≤ 9.99GΩ							
□.□ □ MΩ	□ □.□ MΩ	□ □ □ MΩ	□.□ □ GΩ							
Accuracy	<table border="1"> <thead> <tr> <th>50 nA ≤ i ≤ 100 nA</th> <th>100 nA < i ≤ 200 nA</th> <th>200 nA < i ≤ 1 µA</th> <th>1 µA < i ≤ 1 mA</th> </tr> </thead> <tbody> <tr> <td>± (20 % of reading)</td> <td>± (10 % of reading)</td> <td>± (5 % of reading)</td> <td>± (2 % of reading)</td> </tr> </tbody> </table>	50 nA ≤ i ≤ 100 nA	100 nA < i ≤ 200 nA	200 nA < i ≤ 1 µA	1 µA < i ≤ 1 mA	± (20 % of reading)	± (10 % of reading)	± (5 % of reading)	± (2 % of reading)	i = measured current
50 nA ≤ i ≤ 100 nA	100 nA < i ≤ 200 nA	200 nA < i ≤ 1 µA	1 µA < i ≤ 1 mA							
± (20 % of reading)	± (10 % of reading)	± (5 % of reading)	± (2 % of reading)							
	[In the humidity range of 20 %rh to 70 %rh (no condensation), with no disturbance such as swinging of the test leadwire]									
Hold function	The measured current at the end of the test is held during the PASS period.									
Selection of LOW/GUARD for the GND (*5)	Selection permitted for current measurement between the mode for the GND point connected to the LOW terminal, and the mode using guard.									
	LOW	Connects the GND point to the LOW terminal. Measures the current flowing to the LOW terminal (chassis) (for normal operation).								
	GUARD	Sets the GND point as guard. Measures the current flowing to the LOW terminal, but does not measure the current flowing to the chassis (for high-sensitivity, high-accuracy measurements).								

TOS9200 SERIES

Hipot Tester with Insulation Resistance Test

Item	TOS9200	TOS9201																																																								
Judgement function																																																										
Judgement method/action	<table border="1"> <thead> <tr> <th>Judgement</th> <th>Judgement method</th> <th>Display</th> <th>Buzzer</th> <th>SIGNAL I/O</th> </tr> </thead> <tbody> <tr> <td>UPPER FAIL</td> <td>When the tester detects a resistance exceeding the upper cutoff resistance, it cuts off the output and makes an UPPER FAIL judgement. However, no judgement is made during a voltage rise time (RISE TIME).</td> <td>The FAIL LED lights up. Displayed on the LCD</td> <td>ON</td> <td>Outputs the U FAIL signal</td> </tr> <tr> <td>LOWER FAIL</td> <td>When the tester detects a resistance below the lower cutoff resistance, it cuts off the output and makes a LOWER FAIL judgement. However, no judgement is made until the judgement wait time (WAIT TIME) has elapsed.</td> <td>The FAIL LED lights up. Displayed on the LCD</td> <td>ON</td> <td>Outputs the L FAIL signal</td> </tr> <tr> <td>PASS</td> <td>When the preset time has elapsed without any abnormalities, the tester cuts off the output and makes a PASS judgement.</td> <td>The PASS LED lights up. Displayed on the LCD</td> <td>ON</td> <td>Outputs the PASS signal</td> </tr> </tbody> </table>	Judgement	Judgement method	Display	Buzzer	SIGNAL I/O	UPPER FAIL	When the tester detects a resistance exceeding the upper cutoff resistance, it cuts off the output and makes an UPPER FAIL judgement. However, no judgement is made during a voltage rise time (RISE TIME).	The FAIL LED lights up. Displayed on the LCD	ON	Outputs the U FAIL signal	LOWER FAIL	When the tester detects a resistance below the lower cutoff resistance, it cuts off the output and makes a LOWER FAIL judgement. However, no judgement is made until the judgement wait time (WAIT TIME) has elapsed.	The FAIL LED lights up. Displayed on the LCD	ON	Outputs the L FAIL signal	PASS	When the preset time has elapsed without any abnormalities, the tester cuts off the output and makes a PASS judgement.	The PASS LED lights up. Displayed on the LCD	ON	Outputs the PASS signal																																					
Judgement	Judgement method	Display	Buzzer	SIGNAL I/O																																																						
UPPER FAIL	When the tester detects a resistance exceeding the upper cutoff resistance, it cuts off the output and makes an UPPER FAIL judgement. However, no judgement is made during a voltage rise time (RISE TIME).	The FAIL LED lights up. Displayed on the LCD	ON	Outputs the U FAIL signal																																																						
LOWER FAIL	When the tester detects a resistance below the lower cutoff resistance, it cuts off the output and makes a LOWER FAIL judgement. However, no judgement is made until the judgement wait time (WAIT TIME) has elapsed.	The FAIL LED lights up. Displayed on the LCD	ON	Outputs the L FAIL signal																																																						
PASS	When the preset time has elapsed without any abnormalities, the tester cuts off the output and makes a PASS judgement.	The PASS LED lights up. Displayed on the LCD	ON	Outputs the PASS signal																																																						
	<ul style="list-style-type: none"> The PASS signal is output at the timing preset on PASS HOLD. If HOLD is set, the PASS signal is output continuously until the STOP signal is input. The UPPER FAIL signal and the LOWER FAIL signal are output continuously until the STOP signal is input. The FAIL and PASS buzzer volumes are adjustable. However, they cannot be adjusted individually, as they are set in common. 																																																									
Setting range for the upper resistance (UPPER)	0.01 MΩ to 9.99 GΩ [Below the maximum rated current]																																																									
Setting range for the lower resistance (LOWER)	0.01 MΩ to 9.99 GΩ [Below the maximum rated current]																																																									
Judgement accuracy For both UPPER and LOWER	<table border="1"> <thead> <tr> <th>Judgement current</th> <th>50 nA ≤ i ≤ 100 nA</th> <th>100 nA < i ≤ 200 nA</th> <th>200nA < i ≤ 1 μA</th> <th>1 μA < i ≤ 1 mA</th> </tr> </thead> <tbody> <tr> <td>UPPER, LOWER</td> <td>—</td> <td>—</td> <td>—</td> <td>± (2 % of setting + 3digit)</td> </tr> <tr> <td>0.01 ≤ R < 10.0 MΩ</td> <td>—</td> <td>—</td> <td>± (5 % of setting + 5digit)</td> <td>± (2 % of setting + 3digit)</td> </tr> <tr> <td>10.0 ≤ R < 50.0 MΩ</td> <td>—</td> <td>—</td> <td>± (5 % of setting + 5digit)</td> <td>± (2 % of setting + 3digit)</td> </tr> <tr> <td>50.0 ≤ R < 100 MΩ</td> <td>—</td> <td>—</td> <td>± (5 % of setting + 5digit)</td> <td>± (2 % of setting + 3digit)</td> </tr> <tr> <td>100 MΩ ≤ R < 200 MΩ</td> <td>—</td> <td>± (10 % of setting + 5digit)</td> <td>± (5 % of setting + 5digit)</td> <td>± (2 % of setting + 3digit)</td> </tr> <tr> <td>200 MΩ ≤ R < 500 MΩ</td> <td>± (20 % of setting + 5digit)</td> <td>± (10 % of setting + 5digit)</td> <td>± (5 % of setting + 5digit)</td> <td>± (2 % of setting + 3digit)</td> </tr> <tr> <td>500 MΩ ≤ R < 1.00 GΩ</td> <td>± (20 % of setting + 5digit)</td> <td>± (10 % of setting + 5digit)</td> <td>± (5 % of setting + 5digit)</td> <td>± (2 % of setting + 3digit)</td> </tr> <tr> <td>1.00 GΩ ≤ R < 2.00 GΩ</td> <td>± (20 % of setting + 10digit)</td> <td>± (10 % of setting + 5digit)</td> <td>± (5 % of setting + 5digit)</td> <td>—</td> </tr> <tr> <td>2.00 GΩ ≤ R < 5.00 GΩ</td> <td>± (20 % of setting + 20digit)</td> <td>± (10 % of setting + 10digit)</td> <td>± (5 % of setting + 5digit)</td> <td>—</td> </tr> <tr> <td>5.00 GΩ ≤ R < 10.0 GΩ</td> <td>± (20 % of setting + 20digit)</td> <td>± (10 % of setting + 10digit)</td> <td>—</td> <td>—</td> </tr> </tbody> </table>			Judgement current	50 nA ≤ i ≤ 100 nA	100 nA < i ≤ 200 nA	200nA < i ≤ 1 μA	1 μA < i ≤ 1 mA	UPPER, LOWER	—	—	—	± (2 % of setting + 3digit)	0.01 ≤ R < 10.0 MΩ	—	—	± (5 % of setting + 5digit)	± (2 % of setting + 3digit)	10.0 ≤ R < 50.0 MΩ	—	—	± (5 % of setting + 5digit)	± (2 % of setting + 3digit)	50.0 ≤ R < 100 MΩ	—	—	± (5 % of setting + 5digit)	± (2 % of setting + 3digit)	100 MΩ ≤ R < 200 MΩ	—	± (10 % of setting + 5digit)	± (5 % of setting + 5digit)	± (2 % of setting + 3digit)	200 MΩ ≤ R < 500 MΩ	± (20 % of setting + 5digit)	± (10 % of setting + 5digit)	± (5 % of setting + 5digit)	± (2 % of setting + 3digit)	500 MΩ ≤ R < 1.00 GΩ	± (20 % of setting + 5digit)	± (10 % of setting + 5digit)	± (5 % of setting + 5digit)	± (2 % of setting + 3digit)	1.00 GΩ ≤ R < 2.00 GΩ	± (20 % of setting + 10digit)	± (10 % of setting + 5digit)	± (5 % of setting + 5digit)	—	2.00 GΩ ≤ R < 5.00 GΩ	± (20 % of setting + 20digit)	± (10 % of setting + 10digit)	± (5 % of setting + 5digit)	—	5.00 GΩ ≤ R < 10.0 GΩ	± (20 % of setting + 20digit)	± (10 % of setting + 10digit)	—	—
Judgement current	50 nA ≤ i ≤ 100 nA	100 nA < i ≤ 200 nA	200nA < i ≤ 1 μA	1 μA < i ≤ 1 mA																																																						
UPPER, LOWER	—	—	—	± (2 % of setting + 3digit)																																																						
0.01 ≤ R < 10.0 MΩ	—	—	± (5 % of setting + 5digit)	± (2 % of setting + 3digit)																																																						
10.0 ≤ R < 50.0 MΩ	—	—	± (5 % of setting + 5digit)	± (2 % of setting + 3digit)																																																						
50.0 ≤ R < 100 MΩ	—	—	± (5 % of setting + 5digit)	± (2 % of setting + 3digit)																																																						
100 MΩ ≤ R < 200 MΩ	—	± (10 % of setting + 5digit)	± (5 % of setting + 5digit)	± (2 % of setting + 3digit)																																																						
200 MΩ ≤ R < 500 MΩ	± (20 % of setting + 5digit)	± (10 % of setting + 5digit)	± (5 % of setting + 5digit)	± (2 % of setting + 3digit)																																																						
500 MΩ ≤ R < 1.00 GΩ	± (20 % of setting + 5digit)	± (10 % of setting + 5digit)	± (5 % of setting + 5digit)	± (2 % of setting + 3digit)																																																						
1.00 GΩ ≤ R < 2.00 GΩ	± (20 % of setting + 10digit)	± (10 % of setting + 5digit)	± (5 % of setting + 5digit)	—																																																						
2.00 GΩ ≤ R < 5.00 GΩ	± (20 % of setting + 20digit)	± (10 % of setting + 10digit)	± (5 % of setting + 5digit)	—																																																						
5.00 GΩ ≤ R < 10.0 GΩ	± (20 % of setting + 20digit)	± (10 % of setting + 10digit)	—	—																																																						
	Judgement current = test voltage/(UPPER,LOWER) [In the humidity range of 20 %rh to 70 %rh (no condensation), with no disturbance such as swinging of the test leadwire] [In LOWER judgement, at least 0.5 s is necessary for testing after the WAIT TIME has elapsed. In LOWER judgement for 200 nA or lower, a wait time of at least 1.0 s is necessary.]																																																									
Time																																																										
Setting range for the voltage rise time (RISE TIME)	0.1 s to 200 s																																																									
Setting range for the test time (TEST TIME)	0.5 s to 999 s With the TIMER OFF function																																																									
Setting range for the judgement wait time (WAIT TIME)	0.3 s to 10 s [RISE TIME + TEST TIME > WAIT TIME]																																																									
Accuracy	± (100 ppm + 20 ms)																																																									

*5 When the GND is set to GUARD, current measurement is disabled if the part of the DUT connected to the LOW terminal is grounded, which poses extreme danger. Never ground the DUT.
In ordinary operation, set the GND to LOW.

General Specifications

Item	TOS9200	TOS9201
Environment		
Installation location	Indoors at an altitude of up to 2000 m	
Warranty range	Temperature	5 °C to 35 °C
	Humidity	20 %rh to 80 %rh (No condensation)
Operating range	Temperature	0 °C to 40 °C
	Humidity	20 %rh to 80 %rh (No condensation)
Storage range	Temperature	-20 °C to 70 °C
	Humidity	90 %rh or less (No condensation)
Power requirements		
Nominal voltage range (Allowable voltage range)	100 V to 120 V AC / 200 V to 240 V AC (85 V to 130 V AC / 170 V to 250 V AC) Selectable	
Power consumption	Using no load (READY)	100 VA or less
	Using the rated load	Maximum of 800 VA
Allowable frequency range	47 Hz to 63 Hz	
Insulation resistance	30 MΩ or more (500 V DC) [between the AC LINE and chassis]	
Hipot	1390 V AC, 2 seconds, 20 mA or less [between the AC LINE and chassis]	
Ground bond	25 A AC/0.1 Ω or less	
Electromagnetic compatibility (EMC) (*6)	Conforms to the requirements of the following directive and standard. EMC Directive 2004/108/EC, EN61326, EN61000-3-2, EN61000-3-3 Under following conditions 1. Used test leadwire TL01-TOS which is supplied. 2. No discharge occurs at outside of the tester. 3. Used the shielded cable which length is less than three meters when the SIGNAL I/O is used.	
Safety (*6,7)	Conforms to the requirements of the following directive and standard. Low Voltage Directive 2006/95/EC, EN61010-1, Class I, Pollution degree 2	
Dimensions (maximum)	430 (455) W x 132 (150) H x 370 (440) D mm	
Weight	Approx. 19 kg	

TOS9200 SERIES

Hipot Tester with Insulation Resistance Test

Item	TOS9200	TOS9201
Accessory		
AC Power cable	1 pc.	
High-voltage test lead wire TL01-TOS (1.5 m)	1 set	
Interlock jumper	1 pc.	
High-Voltage Danger seal	1 sheet	
Fuse	1 pc.	
Operation Manual	Operation Manual for Tester: 1 copy, Operation for GPIB/RS-232C Interface: 1 copy	

*6 Only on models that have CE marking on the panel. Not applicable to custom order models.

*7 This instrument is a Class I equipment. Be sure to ground the protective conductor terminal of the instrument. The safety of the instrument is not guaranteed unless the instrument is grounded properly.

High-Voltage Scanner (TOS9220/9221)

Item	TOS9220	TOS9221
Maximum rating voltage	AC DC	5.0 kV 6.0 kV
Number of channels	4 (Each channel is settable to HIGH, LOW, or OPEN.)	
Maximum number of scanners connected	4 scanners, Channel numbers are determined in order of connection to the TOS9200/9201 tester. 1 st scanner CH1 to CH4 2 nd scanner CH5 to CH8 3 rd scanner CH9 to CH12 4 th scanner CH13 to CH16	
Contact check function	None (*1)	Provided
Lamps and LEDs	POWER DANGER CHANNEL	Lights as it is interlocked with the POWER switch of the TOS9200/9201 tester Lights as it is interlocked with the DANGER lamp of the TOS9200/9201 tester Lights during a test at each channel HIGH: red; LOW: green; Under contact check: orange
Power requirements		
Nominal voltage range (allowable voltage range)	100 V to 120 V AC/200 V to 240 V AC (85 V to 132 V AC/170 V to 250 V AC) Automatic switching	
Power consumption	In READY state During test	Approx. 12 VA 40 VA maximum
Allowable frequency range	47 Hz to 63 Hz	
Insulation resistance	30 M Ω or more (500 V DC) [between the AC LINE and chassis]	
Hipot	1390 V AC, 2 seconds, 10 mA or less [between the AC LINE and chassis]	
Ground bond	25 A AC/0.1 Ω or less	
Electromagnetic compatibility (EMC) (*2)	Conforms to the requirements of the following directive and standard. EMC Directive 2004/108/EC, EN61326, EN61000-3-2, EN61000-3-3 Under following conditions 1. Used test leadwire TL07-TOS which is supplied. 2. No discharge occurs at outside of the tester. 3. Used the shielded cable which length is less than three meters when the SIGNAL I/O is used.	
Safety (*2,3)	Conforms to the requirements of the following directive and standard. Low Voltage Directive 2006/95/EC, EN61010-1, Class I, Pollution degree 2	
Environment		
Installation location	Indoors and at altitudes up to 2000 m	
Warranty range	Temperature Humidity	5 °C to 35 °C 20 %rh to 80 %rh (no condensation)
Operating range	Temperature Humidity	0 °C to 40 °C 20 %rh to 80 %rh (no condensation)
Storage range	Temperature Humidity	-20 °C to 70 °C 90 %rh or less (no condensation)
Dimensions	430(435)W \times 88(105)H \times 370(415) Dmm	
Weight	Approx. 6.5 kg	
Accessories		
AC power cable	1 pc.	
High-voltage test leadwires, red	4 pc. (1.5 m each)	8 pc. (1.5 m each)
High-voltage leads for parallel connection	1 set (0.5 m each)	
Interface cable	1 pc.(0.5 m)	
Channel-indication stickers	For the panel face: 1 sheet; for the test leadwires: 1	
“HIGH VOLTAGE, DANGER” stickers	2 sheets	
Fuses	2 pc. (including a spare contained in the fuse holder)	
Operation Manual	1 copy	

*1 When the contact check function is activated on the TOS9220/9201 tester, the tester conducts a contact check up to the output terminals of the TOS9220 scanner.

*2 Only on models that have CE marking on the panel. Not applicable to custom order models.

*3 This instrument is a Class I equipment. Be sure to ground the protective conductor terminal of the instrument. The safety of the instrument is not guaranteed unless the instrument is grounded properly.

[Measurement accuracy achieved when the scanner and the TOS9220/9201 tester are connected]

In an AC hipot test, a current of approx. 22 μ A/kV flows per scanner due to stray capacitance in the scanner in comparison with use of the TOS9220/9201 tester alone. Note that this current may contribute to errors in current measurements conducted by the TOS9220/9201 tester.

External dimensional diagrams

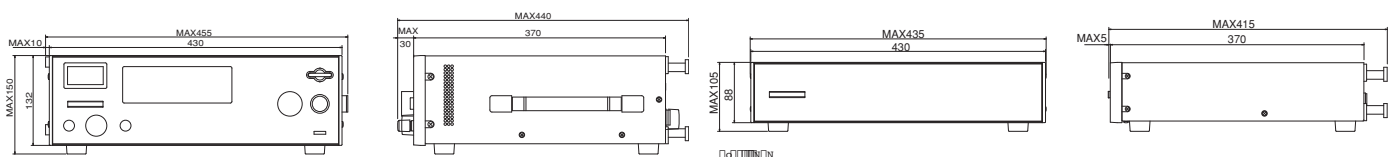

Unit: mm

TOS9213S

Hipot Tester with Insulation Resistance Test

For the insulation testing of PV(Photovoltaic) module



TOS9213S(DCW/IR)

GPIB

RS-232C

Accompanied with the features and performance of TOS9200 series, and it extends additional features and specifications exclusively applied to the PV module testing.

The TOS9213S, DC Withstanding Voltage/Insulation Resistance Tester, is the test instrument that can handle the insulation test with high voltage and high resolution required for the evaluation of the PV module, Cable, Connector, and Junction Box. The TOS9213S is equipped with functions of the DC withstanding voltage testing and the insulation resistance testing accompanied with the features and performance of Kikusui's high-end model TOS9200 series, and it extends additional features and specifications exclusively applied to the PV module testing. Furthermore, the TOS9213S improves the current measurement accuracy of the DC withstanding voltage testing from the original specification of the TOS9000 series.

- Up to 10 kV/5 mA with a maximum output of 50 W in DC withstanding voltage test
- Perform insulation resistance testing in the range of -25 V to -1000 V / 0.01 M to 9.99 G
- Applies for the testing of IEC61730-2 standard
- High-precision current measurement, 1 μ A of the setting resolution for judgement
- Low output ripple of 100V p-p at 10 kV with consideration of capacitive load
- Rise-time control function makes a voltage to be increased slowly and it will not give effect of the stress to the PV module
- The judgement method of the insulation resistance test can be selected by using the current value in addition to the resistance value
- The phenomena of voltage appearance by the dielectric absorption, the forcible discharge timer function can be set up to 300 seconds

TOS9213S

Hipot Tester with Insulation Resistance Test

Hipot Tester

Output section(DC)		
Output-voltage range	0.05V to 10.0kV	
	Resolution	10V
	Accuracy	±(1.5% of setting +20V)
Maximum rated load *1	50W(10kV/5mA)	
Maximum rated current	5mA	
Ripple	No load at 10kV	100Vp-p Typ.
	Maximum rated load	100Vp-p Typ.
Voltage regulation	1% or less [maximum rated load → no load]	
Short-circuit current	40mA Typ.	
Discharge function	Forced discharge at the end of test (discharge resistance: 500 k) The discharge time can be set to a value from 0.5 s to 300 s. (*2)	
Start voltage	The voltage at the start of the test can be set as the start voltage.	
	Setting range	0% to 99% of the test voltage (resolution of 1%)
Output-voltage monitoring function	If the output voltage exceeds ±(10% of setting + 50V), output is cut off and the protection function activates.	
Voltmeter		
Analog	Scale	10kV DC F.S
	Accuracy	±5% F.S
	Indicator	Mean-value responsive
Digital	Measurement range	0.00 to 10.5kV DC
	Resolution	10V
	Accuracy	±(1.0% of reading + 20 V)
	Response	Mean-value responsive (response time of 200 ms)
	HOLD function	The voltage measured at the end of test is held during the PASS and FAIL period.

*1: Limitation on output
The tester's withstanding voltage generator is designed to radiate half as much heat as the rated output, in consideration of the size, weight, cost, and other factors of the tester. It is therefore necessary to use the tester within the ranges specified below. Operations deviating from these ranges may heat the output section excessively, thereby activating the protective circuit. In such a case, suspend the test and wait until the temperature falls to the normal level.

Output limitation in withstanding voltage testing

Ambient temperature		Upper reference	Pause	Output time
t ≤ 40°C	DC	2.5mA < i	At least as long as the output time	Maximum of 1 minute
		i ≤ 2.5mA	At least as long as the judgement wait time (WAIT TIME)	Continuous output possible

[Output time = voltage rise time + test time + voltage fall time]

*2: About the discharge time setting
If you set the discharge time to 0.0 s or if the voltage between the output terminals exceeds approximately 30 V even after the specified discharge time has passed, the TOS9213S will continue discharging until the voltage between the output terminals falls below approximately 30 V.

Ammeter	
Measurement range	0.00 mA to 5.5 mA DC
Accuracy *3	0µA to 2.00mA: ±(3% of reading + 5µA)
	2.01mA to 5.50mA: ±(3% of reading + 10µA)
Response	Mean-value responsive (response time of 200 ms)
Hold function	The measured current at the end of the test is held during the PASS period.

Judgement function	
Setting range for the upper reference (UPPER)	1µA to 999µA 1µA STEP 1.00mA to 5.50mA 0.01mA STEP
Setting range for the lower ref-erence (LOWER)	1µA to 999µA 1µA STEP 1.00mA to 5.50mA 0.01mA STEP (With the LOWER OFF function)
Judgement accuracy *3	0µA to 2.00mA: ±(3% of setting + 5µA) 2.01mA to 5.50mA: ±(3% of setting + 10µA)
Response switching function	The current detection response for UPPER FAIL judgement can be set to FAST/MID/SLOW (*4)

Time	
Setting range for the voltage rise time (RISE TIME)	0.1s to 200s
Setting range for the test time (TEST TIME)	0.3s to 999s (With the TIMER OFF function)

*3: When the GND LOW/GUARD setting is set to LOW, the humidity must not exceed 70 % rh.

*4: In the MID and SLOW modes, depending on the discharge method, the voltage monitoring function may operate and the TOS9213S may enter the PROTECTION status before UPPER FAIL detection takes place.

*The highlighted text in red indicates the improved specification exclusively applied to the PV module testing.

Insulation Resistance Tester

Output section										
Output-voltage range	-25V to -1000V									
	Resolution	1V								
	Accuracy	±(1.5% of setting+2V)								
Maximum rated load	1W(-1000V/1mA)									
Maximum rated current	1mA									
Ripple	1 kV no-load	2 Vp-p or less								
	Maximum rated load	10 Vp-p or less								
Voltage regulation	1% or less [Maximum rated load no load]									
Short-circuit current	12 mA or less									
Discharge function	Forced discharge at the end of test (discharge resistance: 25 kΩ)The discharge time can be set to a value from 0.5s to 300 s.(*2)									
Output-voltage monitoring function	If the output voltage exceeds ±(10% of the setting + 50 V), output is cut off and the protection function activates.									
Voltmeter										
Analog	Scale	10kV DC F.S								
	Accuracy	±5% F.S								
	Indicator	Mean-value responsive								
Digital	Measurement range	0 to -1200V								
	Resolution	1V								
	Accuracy	±(1.0% of reading +1V)								
Resistance meter										
Measurement range	0.01 M - 9.99 G (Within the maximum rated current range of 1 mA to 50 mA)									
Accuracy	<table border="1"> <tr> <td>50nA ≤ i ≤ 100nA</td> <td>100nA < i ≤ 200nA</td> <td>200nA < i ≤ 1µA</td> <td>1µA < i ≤ 1mA</td> </tr> <tr> <td>±(20% of reading.)</td> <td>±(10% of reading.)</td> <td>±(5% of reading.)</td> <td>±(2% of reading.)</td> </tr> </table>		50nA ≤ i ≤ 100nA	100nA < i ≤ 200nA	200nA < i ≤ 1µA	1µA < i ≤ 1mA	±(20% of reading.)	±(10% of reading.)	±(5% of reading.)	±(2% of reading.)
50nA ≤ i ≤ 100nA	100nA < i ≤ 200nA	200nA < i ≤ 1µA	1µA < i ≤ 1mA							
±(20% of reading.)	±(10% of reading.)	±(5% of reading.)	±(2% of reading.)							
[i=measured current]										
[In the humidity range of 20 % to 70 % R.H (no condensation), with no disturbance such as swinging of the test leadwire]										
Judgement function										
Judgement method	The UPPER/LOWER judgement can be switched between the resistance value-based judgement and current value-based judgement. The action for the judgement method by the current value-based judgement, Display, Buzzer, SIGNAL I/O can be referred to the action in Withstanding Voltage Test Mode.									
Setting range for the upper reference(UPPER)	Resistance value-based judgment	0.01 M to 9.99 G [Below the maximum rated current]								
	Current value-based judgment	0.1 µA to 1.00 mA								
Setting range for the lower reference (LOWER)	Resistance value-based judgment	0.01 M to 9.99 G [Below the maximum rated current]								
	Current value-based judgment	0.1 µA to 1.00 mA								
Time										
Setting range for the voltage rise time (RISE TIME)	0.1s to 200s									
Setting range for the test time (TEST TIME)	0.5s to 999s(With the TIMER OFF function)									
General Specifications										
Power requirements	Nominal voltage range (Allowable voltage)	100 V to 120 V AC / 200 V to 240 V AC (85 V to 130 V AC / 170 V to 250 V AC).Selectable								
	Using no load (READY)	100 VA or less								
Power con-sumption	Using the rated load	Maximum of 200 VA								
Allowable frequency range	47Hz to 63Hz									
Insulation resistance	30 MΩ or more (500 V DC) [between the AC LINE and chassis]									
Withstanding voltage	1390 V AC, 2 seconds, 20 mA or less [between the AC LINE and chassis]									
Earth continuity	25 A AC/0.1 Ω or less									
Safety	Conforms to the requirements of the following standard. IEC 61010-1 Class I Pollution degree 2									
Warranty range	Temperature/ Humidity	5°C to 35°C/20% to 80% rh(No condensation)								
Operating range	Temperature/ Humidity	0°C to 40°C/20% to 80%rh(No condensation)								
Storage range	Temperature/ Humidity	-20°C to 70°C/90 % RH or less (No condensation)								
Dimensions	430(455)W×132(150)×400(440)Dmm									
Weight	Approx. 13 kg (Approx. 28.66 lb)									
Accessory	AC Power cord 1 pc., High-voltage test leadwire TL01-TOS (1.5 m)1 set, Interlock jumper 1 pc., HIGH VOLTAGE DANGER sticker 1 sheet, Fuse 1pc., Operation Manual 1 copy									

TOS5300 SERIES

Hipot Tester/Hipot Tester with Insulation Resistance Test

A new standard for Hipot & Insulation resistance testing Applied to World-Wide input voltage

TOS5301



TOS5302

TOS5300



TOS5300(ACW)

TOS5301(ACW/DCW)

TOS5302(ACW/IR)

USB

New low-cost standard model that provides thorough operability, reliability and safety.

The “TOS5300 Series” is a series of test instruments used in Hipot tests and insulation resistance tests, two of the four tests regarded as necessary for ensuring the safety of electrical products. With an output of 5 kV/100 mA (AC) and 6 kV/10 mA (DC), the series can be used in Hipot & insulation resistance testing of electronic equipment and electronic parts, based on the requirements of IEC, EN, UL, VDE, JIS, and other international safety standards and the Electrical Appliance and Material Safety Law. Also, the test voltage stability is improved with the adoption of a newly developed switching amplifier. Since the output voltage can be kept constant even when the AC line voltage or frequency changes, consistent testing can be performed, even when the power supply environment is in an unstable region. The TOS5300 is also equipped with a number of features that are capable of meeting a variety of test needs. It is a new low-cost standard model that provides thorough operability, reliability and safety.

- The PWM amp system provides highly-stable output
- 5kV/100mA (500VA) AC Hipot test
- 6kV/maximum output 50W DC Hipot tester (TOS5301)
- 25V-1000V (7 steps), 500V or greater, up to 5.00G Ω Insulation Resistance test
- High-precision measurement $\pm 1.5\%$ of reading (with voltmeter 500V or higher, Ammeter 1mA or higher)
- Rise time(AC/DC) / Fall time(AC) control
- Key lock function and Protection cover for key operation
- Equipped with USB interface

TOS5300 SERIES

Hipot Tester/Hipot Tester with Insulation Resistance Test

Basic performance

The achievement of AC Hipot testing with a constant stable output! [Input voltage variation : $\pm 0.3\%$]

A conventional Hipot tester boosts and outputs the AC line's input voltage through the use of a slide transformer. With this slide transformer system, input voltage fluctuations will affect the output, preventing tests from being performed properly. At times, the application of distortion voltage applied to the EUT may cause a failure of new product (accelerating a deterioration of components). Since the TOS5300 Series equips with a high-efficient PWM amplifier that can output a stable high-voltage without being affected by the variation of AC power line, users can perform "safe", "stable", and highly "reliable" tests with confidence, even in regions with large voltage variations.

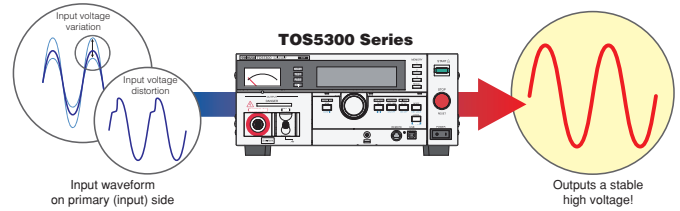

Realizing high-precision measurement with high-resolution and high-speed judgement

Equipped with a high-accuracy, high-resolution of True RMS measurement circuit, including a Voltmeter with $\pm 1.5\%$ of reading (500V or greater) / minimum resolution of 1V, and an Ammeter with $\pm 1.5\%$ of reading (1 mA or more) / minimum resolution of $1\mu\text{A}$. In addition, it is also equipped with an Auto range function, with achieving a judgment accuracy of $\pm 1.5\%$ of reading. The Lower limit judgment accuracy achieves a level of performance equivalent to the Upper limit judgment accuracy that enables to detect for such a poor contact or disconnections of test leads. Moreover, it realizes the fast judgment by the test time of 0.1 second, while reliable testing can be performed, thanks to high-precision, high-resolution, high-speed measurement and the judgment functions.

Supporting the World-wide input voltage

Usable in any country, without changing the input power supply. The instrument not rely on the input power environment. Supplying the stable test voltage with 50/60 Hz frequencies.

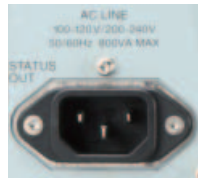

Reducing the tact time

Reduction of the tact time leads to improve the productivity. However, it has been an issue that reducing the tact time may cause to worsen the measurement accuracy when the test time is faster than the measuring response speed. The TOS5300 series has been achieved to set the test time from 0.1s.

6kV/50WDC Hipot test (Model TOS5301)

Capable to perform DC Hipot test up to 6 kV. (Model TOS5301) Equipped with a stable DC/DC converter with a low-ripple and the load variation of 3% or less.

Insulation resistance test for 25V to 1000V*

The TOS5302 is equipped with an insulation resistance tester. The test voltages can be set from 25V, 50V, 100V, 125V, 250V, 500V and 1000V. And for setting at 500V and above, it can perform the insulation resistance test up to 5.00 G Ω .

*At 500V and above, measurements up to 5.00 G Ω are possible.

Protection cover prevents physical operation error in the production site

In many cases, workers on electronic equipment production lines and inspection lines are not technical experts. Therefore, it is possible that the operators may change setting conditions and make operation errors. In order to prevent from such cases, the TOS5300 is equipped with a key lock function and a protection cover to disable a physical key operation from the front panel.

New design of output terminal improves safety and functionality

In consideration of safety for the operator and the environment, the output terminal of HIGH-side has been placed in the most distant location from the control area. The free rotation mechanism protects from twisting (or breaking) of the cable. Also, with having the lock function for the LOW terminal on the main unit, the metal plate is no longer attached to the test lead of LOW-side, and it makes to resist damage to the test lead. Because of elimination of these projected components, the TOS5300 can avoid from unexpected accidents such as when the unit travels to other location. And also when the test lead is snagged on something, or unexpected stress is applied on the test lead, the High (High-voltage) test lead is designed to disconnect easily, but the Low (ground) test lead is designed to resist disconnection. In order to prevent the insertion error, the color coding of the cable are classified to HIGH (red) and LOW (black), and the plug shape of terminal are also different design.



▲ View with the protection cover removed

TOS5300 SERIES

Hipot Tester/Hipot Tester with Insulation Resistance Test

Unless specified otherwise, the specifications are for the following settings and conditions.

- The warm-up time is 30 minutes.
- TYP: These are typical values. These values do not guarantee the performance of the product.
- rdng: Indicates the readout value.
- set: Indicates a setting.
- f.s: Indicates full scale.

Hipot Tester

		TOS5300	TOS5301	TOS5302								
AC output section	Output range	0.05 kV to 5.00 kV										
	Accuracy	±(2 % of set + 20 V) when no load is connected										
	Setting range	0.00 kV to 5.50 kV										
	Resolution	10 V steps										
	Max. rated output *1	500 VA (5 kV/100 mA)										
	Max. rated voltage	5 kV										
	Max. rated current	100 mA (when the output voltage is 0.5 kV or greater)										
	Transformer rating	500 VA										
	Output voltage waveform *2	Sine										
	Distortion	If the output voltage is 0.5 kV or more: 3 % or less (when no load or a pure resistive load is connected).										
	Frequency	50 Hz or 60 Hz										
	Accuracy	±0.5 % (excluding during voltage rise time)										
	Voltage regulation	10 % or less (when changing from maximum rated load to no load)										
	Input voltage variation	±0.3 % (5 kV when no load is connected; power supply voltage: 90 V to 250 V)										
Short-circuit current	200 mA or more (when the output voltage is 1.0 kV or greater)											
Output method	PWM switching											
DC output section	Output range	—	0.05 kV to 6.00 kV	—								
	Accuracy		± (2 % of set + 20 V) When no load is connected									
	Setting range		0.00 kV to 6.20 kV									
	Resolution		10 V STEP									
	Max. rated output *1		50 W (5 kV / 10 mA)									
	Max. rated voltage		6 kV									
	Max. rated current		10 mA									
	Ripple(TYP)		5 kV when no load is connected		50 Vp-p							
	Max. rated load		100 Vp-p									
	Voltage regulation		3% or less (When changing from maximum rated load to no load)									
	Short-circuit current (TYP)		40 mA (when generation 6 kV output)									
Discharge feature	Forced discharge after test completion (discharge resistance: 125 kΩ)											
Start Voltage	The voltage at the start of withstanding voltage tests can be set to 50% of the test voltage.											
Limit Voltage	The test voltage upper limit can be set . AC: 0.00 kV to 5.50 kV, DC: 0.00 kV to 6.20 kV											
Output voltage monitor feature	If output voltage exceeds the specified value + 350 V or is lower than the specified value - 350 V, output is turned off, and protective features are activated.											
Voltmeter	Analog	Scale	6 kV AC/DC f.s									
		Accuracy	± 5 % f.s									
		Indication	Average value response/rms scale									
	Digital	Measurement range	0.000 kV to 6.500 kV AC/DC									
		Display	□ . □□□ kV									
		Accuracy	V < 500 V: ±(1.5 % of rdng + 20 V); V ≥ 500 V: ±1.5 % of rdng									
		Response	True rms (response time: 50 ms)									
Hold feature	After a test is finished, the measured voltage is retained until the PASS or FAIL judgment is cleared.											
Ammeter	Digital	Measurement range	AC: 0.00 mA to 110 mA	AC: 0.00 mA to 110 mA DC: 0.00 mA to 11 mA	AC: 0.00 mA to 110 mA							
		Display	<table border="1"> <tr> <td>i < 1 mA</td> <td>1 mA ≤ i < 10 mA</td> <td>10 mA ≤ i < 100 mA</td> <td>100 mA ≤ i</td> </tr> <tr> <td>□□□ μA</td> <td>□ . □□□ mA</td> <td>□□ . □□ mA</td> <td>□□□ . □ mA</td> </tr> </table>			i < 1 mA	1 mA ≤ i < 10 mA	10 mA ≤ i < 100 mA	100 mA ≤ i	□□□ μA	□ . □□□ mA	□□ . □□ mA
	i < 1 mA	1 mA ≤ i < 10 mA	10 mA ≤ i < 100 mA	100 mA ≤ i								
	□□□ μA	□ . □□□ mA	□□ . □□ mA	□□□ . □ mA								
	Accuracy *3	1.00 mA ≤ i: ±(1.5 % of rdng); i < 1.00 mA: ±(1.5 % of rdng + 30 μA)										
Response	True rms (response time: 50 ms)											
Hold feature	After a test is finished, the measured voltage is retained until the PASS judgment is cleared.											

TOS5300 SERIES

Hipot Tester/Hipot Tester with Insulation Resistance Test

Hipot Tester

		TOS5300	TOS5301	TOS5302																				
Judgment feature	Judgment method and judgment operation	<table border="1"> <thead> <tr> <th>Judgment</th> <th>Judgment method</th> <th>Display</th> <th>Buzzer</th> <th>SIGNAL I/O</th> </tr> </thead> <tbody> <tr> <td>UPPER FAIL</td> <td>If a current that is greater than or equal to the upper limit is detected, the output is turned off, and an UPPER FAIL judgment occurs. During the voltage rise time (Rise Time) of DC hipot tests, an UPPER FAIL judgment also occurs if there is a problem with the voltage rise ratio.</td> <td>FAIL LED lights OVER is displayed on the screen</td> <td>ON</td> <td>Generates a U-FAIL signal</td> </tr> <tr> <td>LOWER FAIL</td> <td>If a current that is less than or equal to the lower limit is detected, the output is turned off, and a LOWER FAIL judgment occurs. This judgment is not performed during voltage rise time (Rise Time) of all tests and during the voltage fall time (Fall Time) of AC hipot tests.</td> <td>FAIL LED lights UNDER is displayed on the screen</td> <td>ON</td> <td>Generates a L-FAIL signal</td> </tr> <tr> <td>PASS</td> <td>If the specified time elapses without any problems, the output is turned off, and a PASS judgment occurs.</td> <td>PASS LED lights</td> <td>ON</td> <td>Generates a PASS signal</td> </tr> </tbody> </table>			Judgment	Judgment method	Display	Buzzer	SIGNAL I/O	UPPER FAIL	If a current that is greater than or equal to the upper limit is detected, the output is turned off, and an UPPER FAIL judgment occurs. During the voltage rise time (Rise Time) of DC hipot tests, an UPPER FAIL judgment also occurs if there is a problem with the voltage rise ratio.	FAIL LED lights OVER is displayed on the screen	ON	Generates a U-FAIL signal	LOWER FAIL	If a current that is less than or equal to the lower limit is detected, the output is turned off, and a LOWER FAIL judgment occurs. This judgment is not performed during voltage rise time (Rise Time) of all tests and during the voltage fall time (Fall Time) of AC hipot tests.	FAIL LED lights UNDER is displayed on the screen	ON	Generates a L-FAIL signal	PASS	If the specified time elapses without any problems, the output is turned off, and a PASS judgment occurs.	PASS LED lights	ON	Generates a PASS signal
	Judgment	Judgment method	Display	Buzzer	SIGNAL I/O																			
UPPER FAIL	If a current that is greater than or equal to the upper limit is detected, the output is turned off, and an UPPER FAIL judgment occurs. During the voltage rise time (Rise Time) of DC hipot tests, an UPPER FAIL judgment also occurs if there is a problem with the voltage rise ratio.	FAIL LED lights OVER is displayed on the screen	ON	Generates a U-FAIL signal																				
LOWER FAIL	If a current that is less than or equal to the lower limit is detected, the output is turned off, and a LOWER FAIL judgment occurs. This judgment is not performed during voltage rise time (Rise Time) of all tests and during the voltage fall time (Fall Time) of AC hipot tests.	FAIL LED lights UNDER is displayed on the screen	ON	Generates a L-FAIL signal																				
PASS	If the specified time elapses without any problems, the output is turned off, and a PASS judgment occurs.	PASS LED lights	ON	Generates a PASS signal																				
<ul style="list-style-type: none"> • If PASS HOLD is enabled, the PASS signal is generated continuously until the TOS5300 Series receives a STOP signal. • The UPPER FAIL and LOWER FAIL signals are generated continuously until the TOS5300 Series receives a STOP signal. • The FAIL and PASS buzzer volume levels can be changed. • For PASS judgments, the length of time that the buzzer sounds for is fixed to 0.2 seconds. Even if PASS HOLD is enabled, the buzzer turns off after 0.2 seconds. 																								
	Upper limit setting	AC: 0.01 mA to 110 mA	AC: 0.01 mA to 110 mA DC: 0.01 mA to 11 mA	AC: 0.01 mA to 110 mA																				
	Lower limit setting	AC: 0.01 mA to 110 mA / OFF	AC: 0.01 mA to 110 mA / OFF DC: 0.01 mA to 11 mA / OFF	AC: 0.01 mA to 110 mA / OFF																				
	Judgment accuracy *3	1.00 mA ≤ i: ±(1.5 % of set), i < 1.00 mA: ±(1.5 % of set + 30 μA)																						
	Current detection method	Calculates the current's true rms value and compares this value with the reference value																						
	Calibration	Calibrated with the rms of a sine wave using a pure resistive load																						
Time	Voltage rise time	0.1 s to 10.0 s																						
	Resolution	0.1 s																						
	Voltage fall time	0.1 s / OFF (only enabled when a PASS judgment occurs)																						
	Test time	0.1 s to 999 s, can be turned off (TIMER OFF)																						
	Resolution	0.1 s to 99.9 s: 0.1 s. 100 s to 999 s: 1 s.																						
	Accuracy	±(100 ppm + 20 ms) excluding Fall Time																						

*1. Regarding the output time limits:

Taking size, weight, and cost into consideration, the heat dissipation capability of the voltage generator that is used for hipot tests has been designed to be one half that of the rated output. Use the TOS5300 Series within the following limits. If you use the product in a manner that exceeds these limits, the output section may overheat, and the internal protection circuits may be activated. If this happens, stop testing, and wait until the TOS5300 Series returns to its normal temperature.

Ambient temperature	Upper limit	Pause time	Output time
t ≤ 40 °C	AC	50 mA < i ≤ 110 mA	Greater than or equal to the output time
		i ≤ 50 mA	Not necessary
	DC	5 mA < i ≤ 11 mA	Greater than or equal to the output time
		i ≤ 5 mA	Greater than or equal to the wait time (WAIT TIME)

(Output time = voltage rise time + test time + voltage fall time)

*2. Regarding the test voltage waveform:

Waveform distortions may occur if a DUT whose capacitance is dependent on voltage (for example, an DUT that consists of ceramic capacitors) is connected as the load. However, if the test voltage is 1.5 kV, the effect of a capacitance of 1000 pF or less can be ignored. Because the product's high-voltage power supply uses the PWM switching method, if the test voltage is 500 V or less, the switching and spike noise proportions are large. The lower the test voltage, the greater the waveform is distorted.

*3. Regarding ammeter and judgment accuracy:

During AC hipot tests, current also flows in the stray capacitance of items such as the measurement leads and jigs. This current that flows in the stray capacitances is added to the current that flows in the DUT, and the sum of these currents is measured. Especially if you want to perform judgments with high sensitivity and accuracy, it is necessary to consider methods to limit the current that flows in these stray capacitances, such as by adding upper and lower limits.

Output voltage	1 kV	2 kV	3 kV	4 kV	5 kV
When using 350 mm long test leads that are suspended in air (TYP)	2 μA	4 μA	6 μA	8 μA	10 μA
When using the accessory, high test lead TL31-TOS (TYP)	16 μA	32 μA	48 μA	64 μA	80 μA

TOS5300 SERIES

Hipot Tester/Hipot Tester with Insulation Resistance Test

Insulation Resistance Tester

		TOS5302												
Output section	Output voltage	25 V, 50 V, 100 V, 125 V, 250 V, 500 V, 1000 VDC (negative)												
	Accuracy	-0 %, +5 %												
	Max. rated load	1 W (-1000 V DC / 1 mA)												
	Max. rated current	1 mA												
	Ripple	1000 V when no load is connected	2 Vp-p or less											
		Max. rated load	10 Vp-p or less											
	Voltage regulation	1 % or less (when changing from maximum rated load to no load)												
	Short-circuit current	12 mA or less												
	Discharge feature	Forced discharge after test completion (discharge resistance: approx. 25 kΩ)												
	Limit voltage	The test voltage upper limit can be set : 25 V, 50 V, 100 V, 125 V, 250 V, 500 V, 1000 V												
Output voltage monitor feature	If output voltage exceeds "10 % of set + 10 V" or is lower than "-(10 % of set + 10 V)," output is turned off, and protective features are activated.													
Volt-meter	Analog	Scale	6 kV AC/DC f.s											
		Accuracy	± 5 % f.s											
		Indication	Average value response/rms scale											
	Digital	Measurement range	0 V to -1200 V											
		Display	<table border="1"> <thead> <tr> <th>Measured voltage</th> <th>V < 100 V</th> <th>100 V ≤ V < 1000 V</th> <th>1000 V ≤ V</th> </tr> </thead> <tbody> <tr> <td>Display</td> <td>□□□ V</td> <td>□□□□ V</td> <td>□□□□□ V</td> </tr> </tbody> </table>	Measured voltage	V < 100 V	100 V ≤ V < 1000 V	1000 V ≤ V	Display	□□□ V	□□□□ V	□□□□□ V			
Measured voltage	V < 100 V	100 V ≤ V < 1000 V	1000 V ≤ V											
Display	□□□ V	□□□□ V	□□□□□ V											
Accuracy	± (1 % of rdng + 1 V)													
Resistance meter	Measurement range / measurement accuracy *4 *5	25 V	0.03 MΩ ≤ R ≤ 25 MΩ / ±2 % of rdng + 2 digits 25 MΩ < R ≤ 125 MΩ / ±5 % of rdng 125 MΩ < R ≤ 250 MΩ / ±10 % of rdng											
		50 V	0.05 MΩ ≤ R ≤ 50 MΩ / ±2 % of rdng + 2 digits 50 MΩ < R ≤ 250 MΩ / ±5 % of rdng 250 MΩ < R ≤ 500 MΩ / ±10 % of rdng											
		100 V	0.100 MΩ ≤ R ≤ 100 MΩ / ±2 % of rdng 100 MΩ < R ≤ 500 MΩ / ±5 % of rdng 500 MΩ < R ≤ 1 GΩ / ±10 % of rdng											
		125 V	0.125 MΩ ≤ R ≤ 125 MΩ / ±2 % of rdng 125 MΩ < R ≤ 625 MΩ / ±5 % of rdng 625 MΩ < R ≤ 1.25 GΩ / ±10 % of rdng											
		250 V	0.250 MΩ ≤ R ≤ 250 MΩ / ±2 % of rdng 250 MΩ < R ≤ 1.25 GΩ / ±5 % of rdng 1.25 GΩ < R ≤ 2.5 GΩ / ±10 % of rdng											
		500 V	0.50 MΩ ≤ R ≤ 500 MΩ / ±2 % of rdng 500 MΩ < R ≤ 2.5 GΩ / ±5 % of rdng 2.5 GΩ < R ≤ 5 GΩ / ±10 % of rdng											
		1000 V	1 MΩ ≤ R < 1 GΩ / ±2 % of rdng 1 GΩ ≤ R ≤ 5 GΩ / ±5 % of rdng											
	Display *5	<table border="1"> <thead> <tr> <th>25 kΩ ≤ R < 1.00 MΩ</th> <th>1.00 MΩ ≤ R < 10.0 MΩ</th> <th>10.0 MΩ ≤ R < 100 MΩ</th> <th>100.0 MΩ ≤ R < 1.00 GΩ</th> <th>1.00 GΩ ≤ R ≤ 9.99 GΩ</th> </tr> </thead> <tbody> <tr> <td>□□□ kΩ</td> <td>□ . □□□ MΩ</td> <td>□□ . □ MΩ</td> <td>□□□ MΩ</td> <td>□ . □□□ GΩ</td> </tr> </tbody> </table>	25 kΩ ≤ R < 1.00 MΩ	1.00 MΩ ≤ R < 10.0 MΩ	10.0 MΩ ≤ R < 100 MΩ	100.0 MΩ ≤ R < 1.00 GΩ	1.00 GΩ ≤ R ≤ 9.99 GΩ	□□□ kΩ	□ . □□□ MΩ	□□ . □ MΩ	□□□ MΩ	□ . □□□ GΩ		
25 kΩ ≤ R < 1.00 MΩ	1.00 MΩ ≤ R < 10.0 MΩ	10.0 MΩ ≤ R < 100 MΩ	100.0 MΩ ≤ R < 1.00 GΩ	1.00 GΩ ≤ R ≤ 9.99 GΩ										
□□□ kΩ	□ . □□□ MΩ	□□ . □ MΩ	□□□ MΩ	□ . □□□ GΩ										
Hold feature	After a test is finished, the measured resistance is retained until the PASS judgment is cleared.													
Current detection response speed	Can be switched between three levels: Fast, Mid, Slow													
Judgment feature	Judgment method and judgment operation	Judgment	Judgment method	Display	Buzzer	SIGNAL I/O								
		UPPER FAIL	If a resistance that is greater than or equal to the upper limit is detected, the output is turned off, and an UPPER FAIL judgment occurs. This judgment is not performed during voltage rise time (Rise Time).	FAIL LED lights; OVER is displayed on the screen	ON	Generates a U-FAIL signal								
		LOWER FAIL	If a resistance that is less than or equal to the lower limit is detected or if a problem occurs during the voltage rise time (Rise Time), the output is turned off, and a LOWER FAIL judgment occurs.	FAIL LED lights; UNDER is displayed on the screen	ON	Generates a L-FAIL signal								
	PASS	If the specified time elapses without any problems, the output is turned off, and a PASS judgment occurs.	PASS LED lights	ON	Generates a PASS signal									
	Upper limit setting range	0.03 MΩ to 5.00 GΩ												
Lower limit setting range	0.03 MΩ to 5.00 GΩ													
Judgment accuracy (the same for UPPER and LOWER)	Measurement accuracy + 2 digits Humidity: 20 %rh to 70 %rh (no condensation). No interference caused by wobbly test leads or other problems. For judgments of 200 nA or less, a test time of at least 1.0 seconds is necessary. If the current detection response speed is set to Mid, a test time of at least 0.3 seconds is necessary. If the current detection response speed is set to Slow, a test time of at least 0.5 seconds is necessary.													
Time	Voltage rise time	10 ms (TYP)												
	Test Time	0.1 s to 999 s, can be turned off (TIMER OFF)												
		Resolution	0.1 s to 99.9 s: 0.1 s, 100 s to 999 s: 1 s.											
Accuracy	± (100 ppm + 20 ms)													

*4. Humidity: 20 %rh to 70 %rh (no condensation). No bends in the test leads. *5. R = measured insulation resistance

TOS5300 SERIES

Hipot Tester/Hipot Tester with Insulation Resistance Test

Other Features / Interfaces

	TOS5300	TOS5301	TOS5302
Double action feature	Tests can only be started by pressing and releasing STOP and then pressing START within 0.5 seconds of releasing the STOP switch.		
Length of time to maintain a PASS judgment result	You can set the length of time to maintain a PASS judgment: 50 ms, 100 ms, 200 ms, 1 s, 2 s, 5 s, or HOLD.		
Momentary feature	Tests are only executed while the START switch is held down.		
Fail mode feature	This feature enables you to prevent remotely transmitted stop signals from clearing FAIL judgments and PROTECTION modes.		
Timer feature	This feature finishes tests when the specified time elapses.		
Output voltage monitor feature	If output voltage exceeds “setting + 350 V” or is lower than “setting - 350 V,” the TOS5300 Series switches to PROTECTION mode, output is turned off, and testing finishes.		
Memory	Up to three sets of test conditions can be saved to memory.		
Key lock	Locks panel key operations (settings and changes).		
Protective features	Under any of the following conditions, the TOS5300 Series switches to the PROTECTION state, immediately turns output off, and stops testing. A message is displayed on the screen.		
Interlock Protection	An interlock signal has been detected.		
Power Supply Protection	An error was detected in the power supply.		
Volt Error Protection	While monitoring the output voltage, a voltage outside of the rated limits was detected. AC or DC hipot tests: ± 350 V Insulation resistance test: $\pm (10\% \text{ of set} + 10 \text{ V})$		
Over Load Protection	During a withstanding voltage test, a value that is greater than or equal to the output limit power was specified. AC hipot test: 550 VA. DC hipot test: 55 VA.		
Over Heat Protection	The internal temperature of the TOS5300 Series became too high.		
Over Rating Protection	During a withstanding voltage test, the output current was generated for a length of time that exceeds the regulated time.		
Calibration Protection	The specified calibration period has elapsed.		
Remote Protection	A connection to or disconnection from the front-panel REMOTE connector was detected.		
SIGNAL I/O Protection	The rear-panel SIGNAL I/O connector's ENABLE signal has changed.		
USB Protection	The USB connector has been disconnected while the TOS5300 Series was being controlled through the USB interface.		
System clock	Set in the following format: year/month/day hour/minutes/seconds.		
Calibration date	Set when the TOS5300 Series is calibrated.		
Calibration period setting	Sets the period before the next calibration is necessary.		
Notification of when the calibration period elapses	Sets the operation that is performed when the specified calibration period elapses. When the TOS5300 Series turns on, it can display a notification or switch to the protection mode and disable testing.		
Interfaces	USB	USB Specification 2.0	
	REMOTE	Front-panel 9-pin MINI DIN connector. By connecting an optional device to this connector, you can control the starting and stopping of tests remotely.	
	SIGNAL I/O	Rear-panel D-sub 25-pin connector	

General Specifications

	TOS5300	TOS5301	TOS5302
Display	VFD: 256 × 64 dots + 4 status indicators		
Backup battery life	3 years (at 25 °C or 77 °F)		
Environment	Installation location	Indoors, at a height of up to 2000 m	
	Spec guaranteed range	Temperature	5 °C to 35 °C (41 °F to 95 °F)
		Humidity	20 %rh to 80 %rh (no condensation)
	Operating range	Temperature	0 °C to 40 °C (32 °F to 104 °F)
		Humidity	20 %rh to 80 %rh (no condensation)
	Storage range	Temperature	-20 °C to 70 °C (-4 °F to 158 °F)
Humidity		90 %rh or less (no condensation)	
Power supply	Nominal voltage range (allowable voltage range)	100 VAC to 240 VAC (90 VAC to 250 VAC)	
	Power consumption	When no load is connected (READY)	100 VA or less
		When rated load is connected	800 VA max.
	Allowable frequency range	47 Hz to 63 Hz	
Insulation resistance (between AC LINE and the chassis)	30 MΩ or more (500 VDC)		
Withstanding voltage (between AC LINE and the chassis)	1390 VAC, 2 seconds, 20 mA or less		
Earth continuity	25 AAC, 0.1 Ω or less		
Safety *6	Complies with the requirements of the following directive and standard. Low Voltage Directive 2006/95/EC, EN 61010-1 Class I Pollution degree 2		
Electromagnetic compatibility (EMC) *6 *7	Complies with the requirements of the following directive and standard. EMC Directive 2004/108/EC, EN 61326-1, EN 61000-3-2, EN 61000-3-3 Applicable under the following conditions The maximum length of all cabling and wiring connected to the TOS5300 Series must be less than 3 m. The high test lead TL31-TOS is being used. Electrical discharges are not occurring outside the DUT.		
Dimensions	See “Outline drawing.”		
Weight	Approx. 14 kg (30.9 lb.)	Approx. 15 kg (33.1 lb.)	Approx. 14 kg (30.9 lb.)
Accessories	Power cord : 1pc. / High test lead (TL31-TOS) : 1set (1 red wire and 1 black wire, each with alligator clips); 1.5 m / D-sub 25-pin plug : 1set ; assembly type / High-voltage warning sticker : 1pc. / User's manual : 1pc. / CD-R : 1pc. *8		

*6. Does not apply to specially ordered or modified TOS5300 Series testers.

*7. Limited to products that have the CE mark on their panels.

*8. Contains the User's Manual, the Communication Interface Manual, the KI-VISA library, and the Safety evaluation test.

TOS8870A

Hipot Tester with Insulation Resistance Test

Global Standard of The Hipot / Insulation Resistance Testers



TOS8870A(ACW/IR)



Applying to various safety standards

Capable to perform the continuous Withstanding Insulation Resistance Testing.

TOS8870A is a combination of a Hipot tester and an insulation resistance tester, and it is capable of performing Hipot Test and Insulation Resistance Test in one continuous process.

(Choice of setting arrangement: AUTO ACW→IR, AUTO IR→ACW, MANU.ACW, MANU.IR.)

The Tester can provide a maximum output of 5kV and an output capacity of 500VA (AC), and can be used for hipot test for the electrical equipment and components in compliance with major electrical standards and ordinances. As for the insulation resistance tester, the tester has two ranges of 500V/1000MΩ and 1000V/2000MΩ.

- Capable of performing hipot test and insulation resistance test in one continuous process.
- Hipot Tester : Maximum Output AC 5kV/100mA and Output Capacity 500VA
- Insulation resistance in 2 ranges: 500V/1000MΩ and 1000V/2000MΩ
- Output characteristics complied with JIS C 1302-1994 for Insulation/Resistance testing
- Voltmeter : JIS class 1, Accuracy : ±1.5% f.s
- GO-NOGO judgment with a window comparator type
- Remote control function
- PASS, FAIL contact signal output
- Equipped with Digital Timer : 0.2sec to 99.9sec/1sec to 999sec
- Downsized approximately 30% in volume (compared to the existing type)

TOS8870A

Hipot Tester with Insulation Resistance Test

Hipot Tester

Test Voltage	Output AC Voltage	0 V to 2.5 kV/0 V to 5 kV (two ranges)
	Output Rating	500 VA (5 kV, 100 mA with 100 V line voltage) *1
	Waveform	AC line waveform
	Voltage regulation	Better than 20% (for maximum rated load to no load, with 100 V line voltage)
Output Voltmeter	Switching	With zero-start type switch
	Scales	2.5 kV f.s / 5 kV f.s, two ranges linear scales
	Class of meter	JIS Class 1
	Accuracy	5 °C to 15°C : ±3 % f.s 15 °C to 35 °C : ±1.5 % f.s (with a sine wave) *2
Judgment of Test Result PASS-FAIL judgment. Output cutoff by leakage current detection	Indication	Mean-value response, effective-value scale graduation
	Judgment	Window comparator system FAIL judgment when leakage current larger than high limit reference value is detected. FAIL judgment also when leakage current smaller than low limit reference value is detected. When FAIL judgment is made, output is cutoff and FAIL alarm is generated. If no FAIL judgment is made after preset period has elapsed, PASS signal is generated.
	High limit reference value	0.5/1/2/4/8/10/100 mA (7 values) By combinations of above values, a range of 0.5 mA to 25.5 mA can be covered in 0.5 mA steps.
	Low limit reference value	0 to one-half of high limit reference values (continuously variable)
	Accuracy of judgment *3	±5 % of high limit ±20 % of low limit reference value (one-half of high limit reference values at maximum counterclockwise). (Other are non-calibrated.)
	Judging method	Absolute value of leakage current is integrated and compared with preset limit reference value
	Calibration	Calibrated with rms value of sine wave, using a pure resistance load.
	No-load output voltage need for detection *4	2.5 kV range Approx. 450 V when set at 100 mA 5 kV range Approx. 550 V when set at 100 mA
	Test time	Timer :0.2 s to 99.9 s (× 0.1 range) ±50 ms
		1 s to 999 s (× 1 range) ±0.5 s
Others	Terminals for monitoring of leakage current	

*1. The heat radiation of the output section of the tester is designed to be 1/2 of the rated output, taking the size, weight, cost, etc., into consideration. Therefore, use it within the limitations shown in Table 1. If it is used in excess of these limitations, the temperature of the output section rises excessively and the internal protection circuit may be activated. In this case, cancel the test for a while and wait until the normal temperature is restored.

*2. Crest factor of 1.35 to 1.41, distortion of 3% or less

*3. The current which flows due to stray capacitances of the output circuit and leadwires causes an error. The overall accuracy of judgement is the above-mentioned accuracy of judgement plus a factor caused by this current. Typical values of this type of currents are shown in the Table 2. Note that, when a test is made with a high voltage and high sensitivity, the current which flows through the stray capacitances may become larger than the preset low limit reference value and low limit judgement may become unavailable.

*4. When making a FAIL judgement test with the output terminals shorted, a certain level of no-load output voltage is needed due to the internal resistance of the output circuit. The voltages shown here are this type of output voltages.

[Table 1.]

Ambient temperature	Test current I	Pause time	Maximum test time
t ≤ 40 °C	25.5 < I v z 100	Test time or longer	30 minutes or less
	I < 25.5	Not required	Continuous test possible

[Table 2.]

Output voltage	1 kV	2 kV	3 kV	4 kV	5 kV
Test alone (without leadwires)	4 μA	8 μA	12 μA	16 μA	20 μA
When 350mm long leadwires are hung in air	6 μA	12 μA	18 μA	24 μA	30 μA
When the accessory leadwire (TL01-TOS) are used	20 μA	40 μA	60 μA	80 μA	100 μA

Test Voltage Waveform

When an AC output voltage is applied to a capacitive load, it is possible that the voltage becomes higher than when in the no-load state due to the capacitance of the load.

Moreover, when the capacitance of the load is voltage dependent (typical examples are ceramic capacitors), the voltage waveform may be distorted. When the test voltage is 1.5kV, however, effects caused by a capacitance of 1000pF or less are negligible.

Insulation Resistance Tester

Measuring Voltage	500 V or 1000 V DC, negative polarity (two ranges)	
Measuring terminal voltage	0% to + 5% of rated measuring voltage (At rated measuring current or less)	
Output current	Rated measuring current	1.0 mA
	Short circuit current	12 mA or less
Effective Measuring Ranges	500 V range	1 MΩ to 1000 MΩ
	1000 V range	2 MΩ to 2000 MΩ
Values center of scale	500 V range	20 MΩ
	1000 V range	50 MΩ
Accuracy	1st effective measuring range : ±5 % of the indicated value *1 2nd effective measuring range : ±10 % of the indicated value *1	
Judgment of Test Result PASS-FAIL judgment	Judgment	Window comparator system (mutually independent settings of high limit and low limit) FAIL judgment when measured resistance is smaller than low limit reference value. FAIL judgment when measured resistance is larger than high limit reference value. When FAIL judgment is made, output is cutoff and FAIL alarm is generated. If no FAIL judgment is made after preset period has elapsed, PASS signal is generated.
	Limit reference value setting range	Low and high limit reference values can be set at any points within the effective measuring range of the Tester.
	Accuracy of judgment	1st effective measuring range : ±10 % of set value *1 2nd effective measuring range : ±15 % of set value *1
Test time	Waiting-time for judgment	Approx. 0.3 s
	Timer :0.5 s to 99.9 s (× 0.1 range) ±50 ms	
	1 s to 999 s (× 1 range) ±0.5 s	

*1. At 25 °C ± 10 °C

The 1st effective measuring range is from 1/1000 to 1/2 of the maximum effective scale value. The 2nd effective measuring range is from the above to the maximum effective scale value.

TOS8870A

Hipot Tester with Insulation Resistance Test

General Specifications

Types of test	1.AUTO ACW→IR	Hipot test first and insulation resistance test next	
	2.AUTO IR→ACW	Insulation resistance test first and hipot test next	
	3.MANUAL ACW	Hipot test alone	
	4.MANUAL IR	Insulation resistance test alone	
Remote Control	Test / Reset control	Low active control	
		Input conditions *1	
		High level input voltage	11 V to 15 V
		Low level input voltage	0 V to 4 V
		Low level sweep out current	5 mA or less
		Input pulse width	20 ms minimum
Interlock		Protection is effected when INTERLOCK terminal is made open (test is disabled).	
Output signals *2	Signal Name	Conditions for Signal Generation	Type of Signals
	TEST ON signal	Delivered during entire test-on period.	Make-contact signal and lamp
	PASS signal	Delivered when PASS judgment is made, for approximately 50 ms.	Make-contact signal, lamp and buzzer
	ACW/FAIL alarm	Delivered continuously when FAIL judgment of hipot test is made.	Make-contact signal, lamp and buzzer
	IR/FAIL alarm	Delivered continuously when FAIL judgment of insulation resistance test is made.	Make-contact signal, lamp and buzzer
	READY signal	Delivered when in the READY state.	Make-contact signal
Special Test Mode Selectable with DIP switches at rear of Tester	1.DOUBLE ACTION	Test starts only when the START switch is pressed within approximately 0.5 s after pressing the STOP switch.	
	2.PASS HOLD	The PASS state is held.	
	3.MOMENTARY	Test is executed only during the period the START switch is kept pressed.	
	4.FAIL ALARM	FAIL alarm and PROTECTION state cannot be reset by the remote-control STOP signal.	
Ambient Temperature and Humidity	Warranty	5 °C to 35°C / 20 %rh to 80 %rh	
	Operable range	0 °C to 40 °C / 20 %rh to 80 %rh	
	Storage range	-20 °C to 70 °C / 80 %rh or less	
EMC *3	Conforms to the requirements of the following directive and standard.		EMC Directive 2004/108/EC, EN61326, EN61000-3-2, EN61000-3-3
Under following conditions		1. Used HV test leadwire TL01-TOS. 2. No discharge in testing.	
Safety *3,4	Conforms to the requirements of the following directive and standard.		Low Voltage Directive 2006/95/EC, EN61010-1 (Class I, Pollution degree 2)
Power Requirements	Line voltage	100 VAC ± 10 %, 50/60 Hz *5	
	Power consumption	When no load (RESET state) : 15 VA or less *6 When with rated load : Approx. 600 VA	
	Insulation resistance	30 MΩ or more, 500 VDC	
	Hipot	1390 VAC, 2 seconds [between the AC LINE and chassis]	
Dimensions (maximum)	430 (435) W x 132 (155) H x 370 (440) Dmm		
Weight	Approx. 23 kg		
Standard accessories	TL01-TOS High Voltage Test Leadwires, approx. 1.5 m long. 1		
	AC Power cable 1		
	Operation Manual 1		
Options	RC01-TOS Remote Control Box		
	RC02-TOS Remote Control Box		
	HP01A-TOS High Voltage Test Probe, approx. 1.5 m long		
	HP02A-TOS High Voltage Test Probe, approx. 3 m long		
	TL02-TOS High Voltage Test Readwires, approx. 3 m long		
	KRB150-TOS Rackmount Bracket (for JIS)		
KRB3-TOS Rackmount Bracket (for EIA)			

*1. The input terminal is pulled up to +15V supply voltage by resistor. Opening of the input terminal is equivalent to a high level input.

*2. The rating of the signal contacts is 125VAC, 1A, or 30VDC, 1A.

Loudness of the buzzer is adjustable with a knob in common for the PASS signal and FAIL alarm.

*3 Only on models that have CE marking on the panel. Not applicable to custom order models.

*4 This instrument is a Class I equipment. Be sure to ground the protective conductor terminal of the instrument. The safety of the instrument is not guaranteed unless the instrument is grounded properly.

External dimensional diagrams

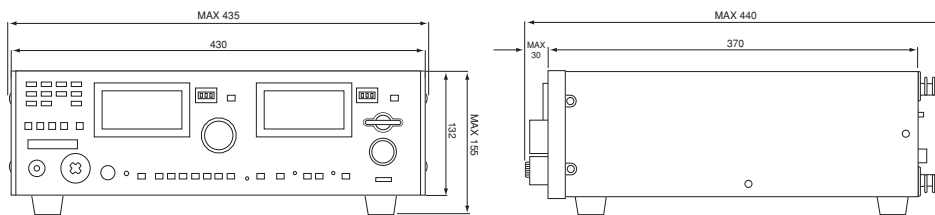

Unit: mm

TOS8830/8040/8030

Hipot Tester/Hipot Tester with Insulation Resistance Test

For use in production and inspection lines

The model TOS8830, TOS8040, TOS8030 are the hipot and insulation resistance testers developed by KIKUSUI, an international brand in the field of electrical safety testers, and are designed specifically for use in production and inspection lines in factories and plants. While retaining the high levels of quality and reliability inherent to our products, these testers are geared to provide what manufacturers want - compactness, light weight, and reasonable price.



TOS8830

Hipot and insulation resistance tests in one model supporting the standard tests

- Withstanding Voltage: AC 4kV/100 mA
- Transformer capacity: 500VA
- Insulation resistance: 500V/999.9 MΩ
- The voltmeter provides a 3-digit digital display.
- The insulation resistance meter provides a 4-digit digital display.
- The window comparator method is adopted for judgment.
- Remote control function
- Output of contact point signals such as PASS and FAIL
- Digital timer adjustable to 1 to 99 seconds

TOS8040

Hipot tester supporting standard tests

- Withstanding Voltage: AC 4kV/100 mA
- Transformer capacity: 500VA
- The voltmeter provides a 3-digit digital display.
- The window comparator method is adopted for judgment.
- Remote control function
- Output of contact point signals such as PASS and FAIL
- Digital timer (0.5 to 9.9 s; 1 to 99 s, Resolution: 0.1 s)

TOS8030

Compact model for the simplified test

- Withstanding Voltage: AC 3kV/100 mA
- Compact and lightweight (approx. 6 kg)
- Digital timer (0.5 to 9.9 s; 1 to 99 s, Resolution: 0.1 s)
- Judgment range: 0.1 mA to 10 mA
- Zero turn-on switch
- Safety-conscious high-voltage output terminal and large DANGER lamp
- Remote control function
- Output of contact point signals such as PASS and FAIL

TOS8830/TOS8040



TOS8030



TOS8830/8040/8030

Hipot Tester/Hipot Tester with Insulation Resistance Test

The specifications are based on the following conditions and settings, unless otherwise specified.

- Warm-up time: 30 minutes • Temperature: 5°C to 35°C • Relative humidity: 20% to 80% (with no dew condensation)
- "xx% of reading" represents xx% of voltmeter (or resistance meter) reading.

Hipot Tester

Item	TOS8830	TOS8040	TOS8030
Output block			
Output voltage range	0.05 kV to 4.00 kV/single range		0.05 kV to 3.00 kV/single range
Maximum rated load (*1)	400 VA (4 kV/100 mA) (at an input voltage of 220V, Transformer capacity 500VA)		30 VA (3 kV/10 mA) (at a nominal input rating)
Output voltage waveform (*2)	AC line waveform		
Voltage regulation	10% or less (during transition from the maximum rated load to no-load, models for a nominal input rating of 220 V) 15% or less (during transition from the maximum rated load to no-load, models for a nominal input rating of 120 V or 100 V)		20% or less (during transition from the maximum rated load to no-load)
Switching	A zero-start switch is used.		
Voltmeter			
Measurement range	0.00 kV to 5.00 kV (Display resolution : 10 V)		0.00 kV to 4.00 kV (Display resolution : 10 V)
Accuracy	± 1.5% full scale or Vm ≥ 1.00 kV: ± (2% of reading + 10 V) Vm < 1.00 kV: ± (2% of reading + 20 V) – whichever is smaller. where FS: full scale (5.00 kV), Vm: measured voltage value		± 1.5% FS or Vm ≥ 1.00 kV: ± (5% of reading), Vm < 1.00 kV: ± (5% of reading + 30 V) – whichever is smaller. where FS: full scale (4.00 kV), Vm: measured voltage value
Response	Mean value response/rms value indication		
Judgment function			
Judgment method	Compares the reference values and measured leakage current using a window comparator. The result is returned as a PASS or FAIL.		Compares the reference values and measured leakage current. The result is returned as a PASS or FAIL.
Upper reference limit	1/2/4/8/10/25/100 mA, 7 ranges May be set from 1 mA to 50 mA in 1 mA steps by a combination.		x0.1 mA range: Can be set from 0.1 mA to 9.9 mA in 0.1 mA steps. x1 mA range: Can be set from 1 mA to 11 mA in 1 mA steps.
Lower reference limit	Continuously variable from 0 to 1/2 of the upper reference limit		-
Judgment accuracy (*3)	± (5% + 20 μA) with respect to the upper reference limit, ± 20% with respect to the lower reference limit (*4)		Iref ≥ 1 mA: ± (5% + 20 μA), Iref < 1 mA: ± (5% + 40 μA) Iref: Reference value
Time			
Test time	1 s to 99 s (the TIMER off function provided), Resolution : 1 s, Accuracy : -0 ms, +50 ms	x0.1 s range: 0.5 s to 9.9 s, x1 s range: 1 s to 99 s (The TIMER OFF function provided), Resolution : x0.1 s range: 0.1 s, x1 s range: 1 s, Accuracy : -0 ms, +50 ms	

*1 : Time limitations on the output

The heat radiation capacity of the output voltage generator section of the tester is designed to be 1/2 of the rated output, in consideration of the instrument dimensions, weight, costs, and other factors. The tester, therefore, must be used under the following time constraints (interval time and output time). If used beyond these limits, the output section may overheat, activating the internal protection circuit. In such cases, always halt testing for a duration equal to or greater than the test duration.

*2 : Test voltage waveform

If AC voltage is applied to a capacitive load, the output voltage in certain cases may rise above the value at no-load, depending on the value of the capacitive element of the load. Moreover, for samples whose capacitance values show voltage dependency (as with ceramic capacitors), waveform distortions may result. However, for a test voltage of 1.5 kV, the effects of a capacitance of 1000 pF or less may be ignored.

*3 : In an AC hipot test, a current also flows in stray capacities such as measurement leads and devices. The approximate current values flowing in these stray capacities are as shown in the table below.

*4 : When the lower reference value is 1/2 of the upper reference limit (i.e., the variable resistor is turned fully clockwise). No calibration is made for other values.

Insulation Resistance Tester

Item	TOS8830
Output section	
Rated output voltage	-500 Vdc
Accuracy	-(500 ⁺²⁰ ₋₀) Vdc
Maximum rated load	0.5 W (-500 V / 1 mA)
Resistance meter	
Effective measurement range	0.50 MΩ - 999.9 MΩ
Accuracy	Rm < 20 MΩ : ±(5 % of reading)
	Rm ≥ 20 MΩ : ±(10 % of reading)
	Rm: measured insulation resistance value

Item	TOS8830
Judgment function	
Judgment method	Compares the reference values and measured resistance using a window comparator. The result is returned as a PASS or FAIL. A reference value can be independently set for the upper and lower limits.
The value set for the upper reference limit	Any of the following 33 values is valid, to a value ranging from 0.50 MΩ to 999.9 MΩ.
The value set for the lower reference limit	
Time	
Test time	1 s to 99 s (the TIMER off function provided) Resolution : 1 s
Accuracy	-0ms, +50 ms

Other Functions / General Specifications

Item	TOS8830	TOS8040	TOS8030
Remote control			
Connector	5-pin DIN connector on the front panel		5-pin DIN connector on the rear panel
Optional devices connectable	Remote control boxes: RC01-TOS and RC02-TOS / High-voltage test probes: HP01A-TOS and HP02A-TOS		
Signal I/O			
Connector (Status signal output)	14-pin screw-less terminal on the rear panel (Output of a READY signal / H.V ON signal / PASS signal / FAIL signal / PROTECTION signal)		

TOS8830/8040/8030

Hipot Tester/Hipot Tester with Insulation Resistance Test

Item	TOS8830	TOS8040	TOS8030
Environment			
Operation environment	Indoor use, Altitude : Up to 2000 m		
Temperature	Specifications assured range : 5°C to 35°C, Operating range : 0°C to 40°C, Storage range : -40°C to 70°C		
Relative humidity	Specifications assured range, Operating range : 20% to 80% (with no dew condensation), Storage range : 90% or less (with no dew condensation)		
General Specifications			
Nominal input rating (Input voltage range)	220 V(200 V to 240 V), 120 V(110 V to 130 V), or 100 V(90 V to 110 V), 50 Hz or 60 Hz		
Power consumption	At no-load (in READY state) 50 VA or less		
At rated load	650 VA maximum		45 VA maximum
Insulation resistance	AC INPUT to chassis 30 MΩ or more (at 500 Vdc)		
Withstand voltage	AC INPUT to chassis 20 mA or less when 1390 Vac is applied for 2 seconds		AC INPUT to chassis 10 mA or less when 1390 Vac is applied for 2 seconds
Ground bond	25 Aac/0.1 Ω or less		
Dimensions (maximum)	320 (330) W x 132 (165) H x 370 (410) Dmm		160 (170) W x 132 (155) H x 230 (270) D mm
Weight	Approx. 18 kg(models for a nominal input rating of 220 V) Approx. 21 kg(models for a nominal input rating of 120 V or 100 V)	Approx. 17 kg(models for a nominal input rating of 220 V) Approx. 21 kg(models for a nominal input rating of 120 V or 100 V)	Approx. 6 kg
Standard accessories	High-voltage test leads TL01C-TOS (approx. 1.5 m): 1 set , Power cord: 1 , INTERLOCK jumper: 1 , Operation Manual: 1 copy		

External dimensional diagrams

TOS8830/8040

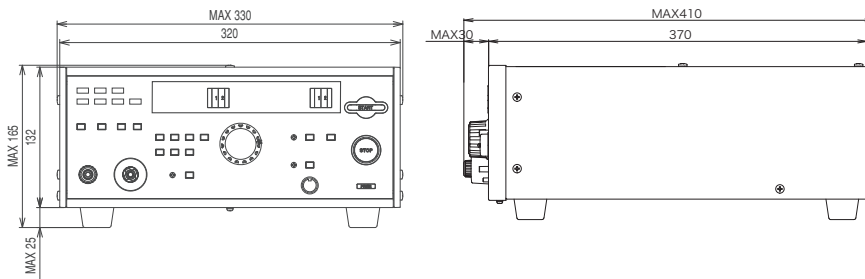

TOS8030

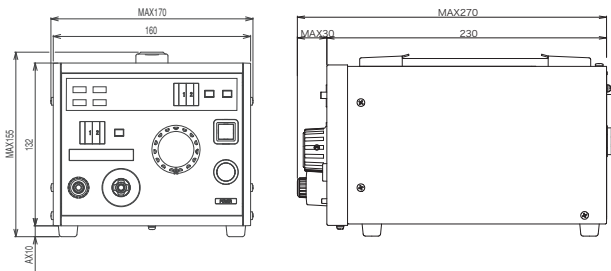

Unit: mm

TOS5101

Hipot Tester

Basic model series with excellent cost performance



TOS5101(ACW/DCW)



High-end model of TOS series having AC, DC10kV output Conforming to demands of various component standards testing and margin test

TOS5101 is designed exclusively for withstand voltage testing of electronic equipment and components conforming to various safety standards. The use of a high luminance, large fluorescent display tube for the display enables data including measured values, status and judgment results to be extremely legible. The PASS/FAIL function employs a window comparator method that enables TOS5101 to make fail judgment of current leakage over the upper reference value and below the lower reference value which can be set on the front panel.

Thus, highly reliable testing can be performed including that for test lead disconnection and defective contact. In addition, in order to prevent erroneous operation and accidents, the TOS5101 is also equipped with a Key Lock function and Interlock function, a high-voltage output terminal having a narrowed insertion port, a large DANGER lamp, and an automatic discharge function (during DC operation) that removes charge from the test piece. These features give the TOS5101 a high degree of safety and reliability.

*In general, when the capacitance of DUT has a voltage dependence (such as a “High-dielectric constant ceramic capacitor”), please take a caution that the waveform distortion may occurs.

- Complies with various safety standards
- AC/DC output (0 to 10 kV)
- Large color display
- Digital voltmeter and ammeter
- Digital timer
- Window comparator type employed for PASS / FAIL judgement.
- Equipped with remote control function
- Various signal outputs
- Automatic discharge function (during DC operation)
- Provided with zero turn-on switch
- Compact size

TOS5101

Hipot Tester

Output block		
Applied Voltage	0 to 5/ 0 to 10 kV AC and DC	
AC		
Maximum Rated*1	500VA / 10 kV, 50 mA	
Waveform	Commercial line waveform	
Voltage Regulation	Max. 15% (for max. rated load to no load)	
Switching	Use of a zero turn-on switch	
DC		
Applied Voltage	50W / 10 kV, 5 mA	
Ripple	100 Vp-p typ. at 10 kV, no load 200 Vp-p typ. at max. rated output	
Maximum Rated*1	Max. 3% (for max. rated load to no load)	
Output Voltmeters		
Analog	Scale	10 kV full scale , AC/DC
	Class	JIS Class 2.5
	Accuracy	±5% of full scale
	AC Indication	Mean value response / rms value scale
Digital	Full Scale	5 kV/ 10 kV full scale
	Accuracy	±1.5% of full scale
	AC Response	Mean value response / rms value display
Ammeter		
Digital	Accuracy	±(5% + 20μA) of upper cutoff current
	AC Response	Mean value response / rms value display
Pass/fail Judgement Function		
Type of Judgement	Window comparator type ● FAIL judgement *When current detected above upper cutoff current *When current detected below lower cutoff current (FAIL signal generated when FAIL judgement made) ● PASS judgement *When set time has elapsed and no abnormality is detected	
Upper cutoff current setting range	AC: 0.1 to 55 mA DC: 0.1 to 5.5 mA	
Lower cutoff current setting range	AC: 0.1 to 55 mA DC: 0.1 to 5.5 mA	
Judgement Accuracy	±(5% of upper cutoff current + 20μA)	
Current Detection	Integration of current absolute value followed by comparison with reference value.	
Calibration	With rms value of sine wave using a pure resistance load.	
No-load output voltage required for detection	Approx. 970 V when set to 50 mA AC Approx. 160 V when set to 5 mA DC	
Test Time Setting Range	0.5 to 999 sec (±10 ms) (timer-off function provided)	
Accuracy	±20 ms	
Line Voltage	100V±10%, 50/60 Hz (Nominal voltages of 110V, 120V, 220V, 230V and 240V available as factory options.)	
Power Requirements		
for line voltage of 100 V	Max. 50 VA under no-load conditions / Approx. 600 VA at rated load	
for line voltage of 100 V to 200 V	Max. 50 VA under no-load conditions / Approx. 600 VA at rated load	
for line voltage of 220 V to 240 V	Max. 50 VA under no-load conditions / Approx. 610 VA at rated load	
Electromagnetic compatibility (EMC) *3	Conforms to the requirements of the following directive and standard.*2 EMC Directive 89/336/EEC EN61326 EN61000-3-2 EN61000-3-3 Under following conditions 1. Used HV test leadwires which is supplied. 2. No discharge in testing. 3. Used the shielded cable which length is less than three meters when the SIGNAL I/O is used.	

Safety *3	Conforms to the requirements of the following directive and standard. *2,4 Low Voltage Directive 73/23/EEC EN61010-1 Class I Pollution degree 2	
Insulation resistance	30 M Ω or more (500 V DC)	
Hipot	1390 VAC, 2 seconds [between the AC LINE and chassis]	
	1200 VAC, 1 second [UL-approved products only]	
Environment	Specification range : 5 °C to 35°C / 20 %rh to 80 %rh	
	Operable range : 0 °C to 40°C / 20 %rh to 80 %rh	
	Storage range : -20 °C to 70 °C / 80 %rh or less	
Dimensions (MAX)	430W × 177(195)H × 370(450)Dmm	
Weight		
for line voltage of 100 V	Approx. 21 kg	
for line voltage of 100 V to 120 V	Approx. 23 kg	
for line voltage of 220 V to 240 V	Approx. 24 kg	
Accessories		
High-voltage test lead	TL01-TOS (max.allowablevoltage: 5 kV /1.5m) TL03-TOS (max.allowablevoltage: 10 kV /1.5m)	
Others	14-pin amphenol plug (assembled)	

*1: Continuous output time may be limited depending on current high limit reference value and ambient temperature.

*2: Only on models that have CE marking on the panel. Not applicable to custom order models.

*3: Not applicable to custom order models.

*4: This instrument is a Class I equipment. Be sure to ground the protective conductor terminal of the instrument. The safety of the instrument is not guaranteed unless the instrument is grounded properly.

External dimensional diagrams

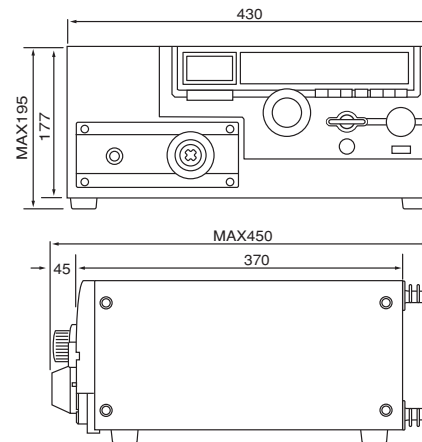

Unit: mm

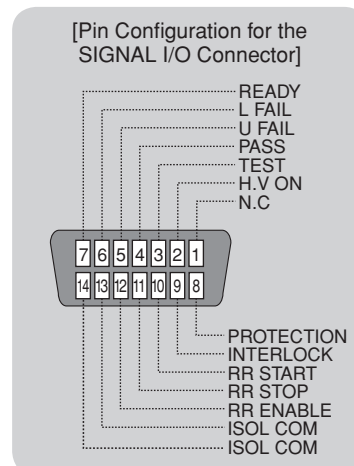

TOS5050A / TOS5051A

Hipot Tester

Supports best-selling model's performance while featuring RS-232C as standard interface



TOS5050A(ACW)
TOS5051A(ACW/DCW)



Capable of record and storage of the test data

The TOS5000A series offers testers specifically designed to conduct hipot testing on electronic devices and components in accordance with the relevant safety standards. Two models are available - TOS5051A with 5 kV AC/DC output and TOS5050A with 5 kV AC output. While inheriting the basic performance of our best-selling TOS5000 series testers, TOS5000A has an additional feature - RS-232C interface - that comes standard with the tester. Because the tester can be connected directly to a PC and a serial printer, test data can be recorded and saved with ease, leading to further enhancement in quality control.

- Complies with various safety standards
- AC/DC output (TOS5051A)
- Large color display
- Digital voltmeter and ammeter
- Digital timer
- Window comparator type employed for PASS/FAIL judgement.
- Equipped with remote control function
- Various signal outputs
- Automatic discharge function (TOS5051A: during DC operation)
- Provided with zero turn-on switch
- Equipped with RS-232C as standard
- Data acquisition software (SD004-TOS5000A/Option)

TOS5050A / TOS5051A

Hipot Tester

Item		TOS5050A	TOS5051A
Output block			
Applied Voltage		0 to 2.5/ 0 to 5 kV AC	0 to 2.5/ 0 to 5 kV AC and DC
AC			
Output Rating (with nominal line voltage)		500VA / 5 kV, 100 mA	
Waveform		Commercial line waveform	
Voltage Regulation (with nominal line voltage)		Max. 15% (for max. rated load to no load)	
Switching		Use of a zero turn-on switch	
DC			
Maximum Output Rating (with nominal line voltage)		—————	50W / 5 kV, 10 mA
Ripple		—————	100 Vp-p typ. at 5 kV, no load 100 Vp-p typ. at max. rated output
Voltage Regulation (with nominal line voltage)		—————	3% or better (against change from maximum rated load to no load)
Output Voltmeters			
Analog	Scale	5 kV full scale (no mirrors), AC	5 kV full scale (no mirrors), AC/DC
	Class	JIS Class 2.5	
	Accuracy	±5% of full scale	
	AC Indication	Mean value response / rms value scale	
Digital	Full Scale	2.5 kV/ 5kV full scale	
	Accuracy	±1.5% of full scale	
	AC Response	Mean value response / rms value display	
Ammeter			
Digital	Accuracy	±(5% + 20μA) of upper cutoff current	
	AC Response	Mean value response / rms value display	
Pass/fail Judgement Function			
Type of Judgement		<ul style="list-style-type: none"> • Window comparator type • If the current detected is larger than the preset upper cutoff current, the tester gives a FAIL judgement. • If the current detected is less than the preset lower cutoff current, the tester gives a FAIL judgement. • As the tester gives a FAIL judgement, it cuts off the output and delivers a FAIL signal. • If the test period elapses without any unacceptable conditions, the tester gives a PASS judgement 	
Upper cutoff current setting range		AC: 0.1 to 110 mA	AC: 0.1 to 110 mA DC: 0.1 to 11 mA
Lower cutoff current setting range		AC: 0.1 to 110 mA	AC: 0.1 to 110 mA DC: 0.1 to 11 mA
Judgement Accuracy		±(5% of upper cutoff current + 20μA)	
Current Detection		The absolute value of current is integrated and compared with the preset cutoff current value.	
Calibration		Calibrated for rms value of sine wave, with pure-resistive load	
No-load output voltage required for detection		Approx. 460 V when set to 100 mA AC	
Test Time Setting Range		0.5 to 999 sec (±10 ms) (timer-off function provided)	
Accuracy		±20 ms	
Line Voltage		100V±10%, 50/60 Hz (Nominal voltages of 110V, 120V, 220V, 230V and 240V available as factory options.)	
RS-232C			
Connector		D-SUB 9-pin connector on the rear panel (conforms to EIA-232-D)Outputs test data and test results	
Protocol		9600 bps, 8 bits Data Length, None-Parity, Stop bit 1 bit	
Function		Query test result, status and measured value, and start and stop test (Incapable of setting test condition)	
Power Requirements			
for line voltage of 100 V		Max. 25 VA under no-load conditions/ Approx. 600 VA at rated load	Max. 50 VA under no-load conditions/ Approx. 610 VA at rated load
for line voltage of 100 V to 200 V		Max. 25 VA under no-load conditions/ Approx. 600 VA at rated load	Max. 50 VA under no-load conditions / Approx. 630 VA at rated load
for line voltage of 220 V to 240 V		Max. 25 VA under no-load conditions/ Approx. 640 VA at rated load	Max. 50 VA under no-load conditions/ Approx. 640 VA at rated load
Electromagnetic compatibility (EMC) *1		Conforms to the requirements of the following directive and standard. EMC Directive 2004/108/EC, EN61326, EN61000-3-2, EN61000-3-3 Under following conditions	
Safty *1,2		<ol style="list-style-type: none"> 1. Used HV test leadwires which is supplied. 2. No discharge in testing. 3. Used the shielded cable which length is less than three meters when the SIGNAL I/O is used. 	
Environment		Low Voltage Directive 2006/95/EC, EN61010-1, Class I, Pollution degree 2	
		Ambient temperature and humidity : 5 °C to 35°C / 20 %rh to 80 %rh	
		Operable temperature and humidity : 0 °C to 40°C / 20 %rh to 80 %rh	
		Storage temperature and humidity : -20 °C to 70 °C / 80 %rh or less	
Dimensions (MAX)		320(330)W X 132(150)H X 300(365)Dmm	
Weight			
for line voltage of 100 V		Approx. 15 kg	Approx. 16 kg
for line voltage of 100 V to 120 V		Approx. 17 kg	Approx. 18 kg
for line voltage of 220 V to 240 V		Approx. 18 kg	Approx. 19 kg
Accessories			
High-voltage test lead		TL01-TOS (max.allowablevoltage: 5 kV /1.5m)	
Others		14-pin amphenol plug (assembled)	

*1: Only on models that have CE marking on the panel. Not applicable to custom order models.

*2: Not applicable to custom order models.

TOS5050A /TOS5051A

Hipot Tester

External dimensional diagrams

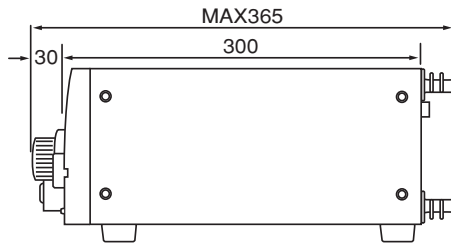
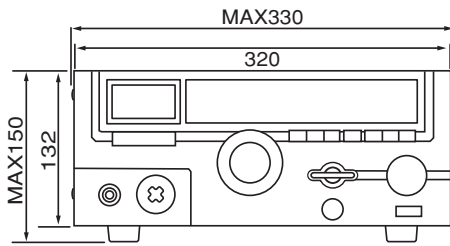

Unit: mm



SD004-TOS5000A

(Data Acquisition for TOS5051A/5050A)

Providing an easy way to collect, manage, and save test results

Highly reliable quality control can be achieved!

SD004-TOS5000A is a software that lets you collect and manage test results generated by our TOS5000A Series hipot testers. Also, SD004-TOS5000A allows you to save, search, and print data with ease. What's more, you can execute or stop the test through a simple operation using a PC.

Features

- Test mode: Execution/stop function and automatic serial number incrementing function
- Search mode: Data item rearrangement and ascending/descending order function, search function ("sounds-like" search supported), print function (layout change supported), and text and HTML file output function.

Operating Environment

Pentium III or later, Windows XP/Windows 2000/Windows Me, CD-ROM drive, mouse, display supporting 800 x 600 resolution, 128 MB or more of memory (recommended), 50 MB or more of free space in hard disk drive (for installation) plus sufficient disk capacity to store necessary files, and RS-232C (data rate of 9600 bps; use an RS-232C cross cable for connection.)

TOS5052

Hipot Tester

Equipped with Rise Time Control Function



TOS5052(ACW)

* While Supplies Last



Rise Time Control function is enable to comply to the Standard requirements for those degradation, destructive testing of sensitive materials

TOS5052 is a special tester designed for withstand voltage testing of electronic equipment and components conforming to various official safety standards. In addition to having an output of 5 kV AC at 100 mA, this model permits output voltage presetting, selection of output frequency (50 or 60 Hz), and rise-time control to control time for voltage to reach a preset level.

The display uses a large, high-brightness, color fluorescent tube for clear display of numbers, operation status, results, and other information.

For fast and accurate testing, the TOS5052 permits dual-axis operation of the test voltage range selector switch and voltage setting knob, and separate up-down keys for determination current and timer settings. Easier to use than ever before, the TOS5052 also incorporates various safety and security features, including key lock, interlock, high-voltage output terminals limiting the number of insertion holes, and large "DANGER" warning lamps. These features make using the TOS5052 safe and reliable.

- Complies with various standards
- Rise-time control function
- High-output test voltage
- Acceptance determination by the window comparator method

[Pin Configuration for the SIGNAL I/O Connector]

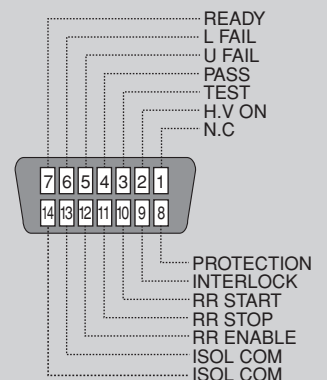

TOS5052

Hipot Tester

Output block		
Output voltage range	0.50 kV to 5.00 kVAC (100 mA output possible range)	
Voltage setting range	0.00 to 2.95 kV/0.00 to 5.45 kV, 2 ranges (3-digit digital setting)	
Setting accuracy	±(2% of setting + 2 digits) at 0.20 kV or higher with no load	
Resolution	10V	
Maximum rated output *1	500VA (5kV/100mA)	
Transformer capacity	500VA	
Output voltage waveform	Sine wave	
Distortion factor	Output voltage of 0.5 kV or higher: 2% or less (under no load or resistive load)	
Frequency	50 or 60 Hz selectable (0.5% of setting, except during voltage rise)	
Voltage regulation	9% or less (maximum rated load to no load)	
Output type	PWM switching	
Output voltage	Output is shut off and protection is effected when the output voltage exceeds the set value plus 200V. "kV" blinks when the output voltage falls below the set voltage minus 100V.	
Output voltmeter		
Analog	Scale	5 kV f.s
	Accuracy	±5% f.s
	Indication	Mean-value response/rms-value indication
Digital	Scale	2.5 kV/5 kV f.s
	Accuracy	±1.5% f.s when the measured voltage does not change within the digital voltmeter's response time.
	Response	Mean-value response/rms-value indication (400 ms response time)
	Hold function	The voltage measured at the end of test is held during the PASS or FAIL interval.
Ammeter		
Digital	Measuring range	0.00 to 110mA
	Accuracy	±(5% of upper cutoff current+ 20μA) when the measured current does not change within the digital ammeter's response time.
	Response	Mean-value response/rms-value indication (400 ms response time)
	Hold function	The current measured at the end of test is held during the PASS interval.
Judgement function		
Judgement system	Window comparator system <ul style="list-style-type: none"> ●FAIL is judged when a current greater than the upper cutoff current is detected. ●FAIL is judged when a current smaller than the lower cutoff current is detected. ●OUTPUT is shut off and FAIL SIGNAL is generated when FAIL is judged. ●PASS SIGNAL is generated when no anomaly is found within the set time. 	
Upper cutoff current range	0.1 to 110mA	
Lower cutoff current range	0.1 to 110mA The TOS5052 makes no lower pass/fail judgment while the voltage is rising and for approximately 0.2s after the voltage is made constant.	
Judgement accuracy	±(5% of upper cutoff current +20μA)	
Current detection method	Absolute value of current is integrated and compared against the reference value.	
Calibration	The root mean square value of sine wave is calibrated using the pure resistive load.	
Illuminators and LEDs		
PASS	Lit for approximately 0.2 s when PASS is judged. Held on when PASS HOLD is enabled.	
UPPER FAIL	Lit when a current greater than the upper cutoff current is detected and FAIL is judged.	
LOWER FAIL	Lit when a current smaller than the lower cutoff current is detected and FAIL is judged.	
Buzzer	<ul style="list-style-type: none"> ●Turned on for approximately 0.2 s when PASS is judged. ●Held on in the following cases:PASS is judged –when PASS HOLD is enabled. UPPER FAIL is judged. LOWER FAIL is judged. The volume of the FAIL or PASS buzzer may be adjusted. The volume setting is common to both FAIL and PASS conditions because the same adjuster is used. 	

Time		
Voltage	Range	0.1 to 99.9s 0.1s step
	Accuracy	±20ms
Test time	Range	0.3 to 999 s(TIMER OFF function available)
	Accuracy	±20ms
Environment		
Warranty range	Temperature	5 to 35°C
	Humidity	20 to 80%rh (non condensing)
Operating range	Temperature	0 to 40°C
	Humidity	20 to 80%rh (non condensing)
Storage range	Temperature	-20 to 70°C
	Humidity	90%rh or less (non condensing)
Power requirement		
Allowable voltage range	90V to 110V The following power voltage options are factory options: (104 V to 125 V)(194 V to 236V) (207 V to 250 V)	
Power consumption	No load time (READY)	150 VA or less
	Rated load time	1,000 VA max.
Allowable frequency range	45Hz to 65Hz	
Insulation resistance	30MΩ min. (500VDC), between AC line and chassis	
Hipot	1,390 V AC (2 seconds), between AC line and chassis	
Ground continuity	25 A AC/ 0.1Ω max.	
Electromagnetic compatibility (EMC)*2		
Conforms to the requirements of the following directive and standard. EMC Directive 2004/108/EC, EN61326, EN61000-3-2, EN61000-3-3 Under following conditions 1. Used HV test leadwires which is supplied. 2. No discharge in testing. 3. Used the shielded cable which length is less than three meters when the SIGNAL I/O is used.		
Safety*2, 3		
Conforms to the requirements of the following directive and standard. Low Voltage Directive 2006/95/EC EN61010-1 Class I, Pollution degree 2		
Dimensions (MAX)	320(330) W × 132(150) H × 420(490) Dmm	
Weight	Approx. 22kg	
Accessories		
AC Power cable	1 Piece.	
High-voltage test leadwire	TL01-TOS (1.5m) 1 set	
14-pin Amphenol plug	1 piece., assembly type	
"DANGER HIGH VOLTAGE" sticker	1 sheet	
AC power fuse	2 pieces. (One in present use and the other as spare in the fuse holder cap)	
Operation manual	1 copy	

*1: Maximum testing time is 30 minutes. However, it may limit the continuous duration (time) of output by upper current limit and the environmental temperature.

*2: Only on models that have CE marking on the panel. Not applicable to custom order models.

*3: This instrument is a Class I equipment. Be sure to ground the protective conductor terminal of the instrument. The safety of the instrument is not guaranteed unless the instrument is grounded properly.

External dimensional diagrams

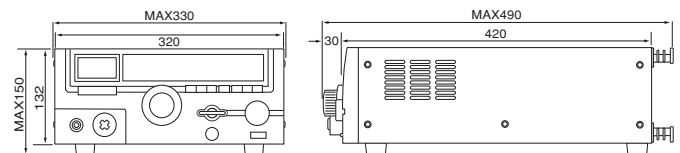

Unit: mm

TOS7200

Insulation Resistance Tester

Complied with the test voltage -25 V to -1000 Vdc of the JIS C 1302-2002



TOS7200(IR)



Testing voltage range -25V to -1,000V,
Resistance measurement range 0.01MΩ to 5,000MΩ

The TOS7200 is an insulation resistance tester available for a wide range of various electric and electronic components, as well as electric and electronic equipment. The output voltage can be set at desired value in the range of - 25 V to -1,000 V with a resolution of 1 V. (conforms with the output characteristics of the JIS C 1302-2002) . As it is fitted with a window comparator and timer function, the tester is capable of efficiently conducting insulation resistance tests based on various safety standards. In addition, this product is equipped with panel memory as standard feature, which can be recalled by remote control, SIGNAL I/O connector, and the RS-232C interface for easy automatic testing system construction.

- Provided with the discharge function
- Equipped with the window comparator
- Hold function
(which holds the measured resistance at the end of testing while PASS judgment is being output)
- Provided with the timer function
- Rear output terminals
- Measured-value monitoring terminals
- Equipped with the panel memory
(enabling 10 different settings to be stored)
- Equipped with the SIGNAL I/O connector and remote control terminal
- Equipped with the RS-232C interface as standard

TOS7200

Insulation Resistance Tester

Output section														
Output voltage range	-25 V to -1000 V													
	Resolution	1 V												
	Accuracy	±(1.5 % of setting + 2 V)												
Maximum rated load	1 W (-1000 V DC/1 mA)													
Maximum rated current	1 mA													
Output terminals	Output type	Floating												
	Isolation voltage	±1000 VDC												
Ripple	1000 V / under no load	2 Vp-p or less												
	Maximum rated load	10 Vp-p or less												
Short-circuiting current	12 mA or less													
Output rise time	50 ms or less (10 % to 90 %) [no load]													
Discharge function	Forced discharge at the end of test (discharge resistance: 25 k Ω)													
Voltmeter														
Measurement range	0 V to -1200 V													
Resolution	1 V													
Accuracy	±(1 % of reading + 1 V)													
Resistance meter														
Measurement range	0.01 M Ω to 5000 M Ω (In the range of over 100 nA to a maximum rated current of 1 mA)													
Display	<table border="1"> <tr> <td>R < 10.0 M Ω</td> <td>10.0MΩ ≤ R < 100.0MΩ</td> <td>100.0MΩ ≤ R < 1000MΩ</td> <td>1000MΩ ≤ R ≤ 5000MΩ</td> </tr> <tr> <td>□.□ □ M Ω</td> <td>□ □ □ M Ω</td> <td>□ □ □ M Ω</td> <td>□ □ □ □ M Ω</td> </tr> </table>				R < 10.0 M Ω	10.0MΩ ≤ R < 100.0MΩ	100.0MΩ ≤ R < 1000MΩ	1000MΩ ≤ R ≤ 5000MΩ	□.□ □ M Ω	□ □ □ M Ω	□ □ □ M Ω	□ □ □ □ M Ω	R = measured insulation resistance	
	R < 10.0 M Ω	10.0MΩ ≤ R < 100.0MΩ	100.0MΩ ≤ R < 1000MΩ	1000MΩ ≤ R ≤ 5000MΩ										
□.□ □ M Ω	□ □ □ M Ω	□ □ □ M Ω	□ □ □ □ M Ω											
Accuracy	<table border="1"> <tr> <td>100 nA < i ≤ 200 nA</td> <td>200 nA < i ≤ 1 μA</td> <td>1 μA < i ≤ 1 mA</td> <td></td> </tr> <tr> <td>± (10 % of reading)</td> <td>± (5 % of reading)</td> <td>± (2 % of reading)</td> <td>i = measured output-voltage value/measured resistance value</td> </tr> </table> <p>[In the humidity range of 20 %rh to 70 %rh (no condensation), with no disturbance such as swinging of the test leadwire]</p>				100 nA < i ≤ 200 nA	200 nA < i ≤ 1 μA	1 μA < i ≤ 1 mA		± (10 % of reading)	± (5 % of reading)	± (2 % of reading)	i = measured output-voltage value/measured resistance value		
100 nA < i ≤ 200 nA	200 nA < i ≤ 1 μA	1 μA < i ≤ 1 mA												
± (10 % of reading)	± (5 % of reading)	± (2 % of reading)	i = measured output-voltage value/measured resistance value											
Measurement range	The current measurement range is selectable between AUTO and FIX.													
	AUTO	Automatically changes the current measurement range according to the measured current value.												
FIX	Fixes the current measurement range based on the output voltage set value and LOWER set value (in UPPER OFF status).													
Holding function	Holds the resistance value obtained at the end of testing while a PASS judgment is being output.													
Judgment function														
Judgement method/action	Judgement	Judgement method	Display	Buzzer	SIGNAL I/O									
	UPPER FAIL	If a resistance value equal or higher than the upper resistance is detected, the tester shuts off the output and returns an UPPER FAIL judgment.	FAIL LED lights. UPPER LED lights.	ON	Outputs an U FAIL signal									
	LOWER FAIL	If a resistance value equal or less than the lower resistance is detected, the tester shuts off the output and returns a LOWER FAIL judgment. Note that no judgment is made within the judgment wait time (WAIT TIME) after the start of the test.	FAIL LED lights. LOWER LED lights.	ON	Outputs a L FAIL signal									
	PASS	If no abnormality is found when the set test time has elapsed, the tester shuts off the output and returns a PASS judgment.	PASS LED lights.	ON	Outputs a PASS signal									
<ul style="list-style-type: none"> A PASS signal is output for approx. 200 ms. However, if the PASS HOLD function is set to "HOLD," the signal is continuously output until a STOP signal is input. An UPPER FAIL or LOWER FAIL signal is continuously output until a STOP signal is input. The FAIL and PASS buzzer volumes are adjustable. However, they cannot be adjusted individually, as they are set in common. 														
Setting range for the upper resistance (UPPER)	0.01 M Ω to 5000 M Ω [In the range of the maximum rated current or less]													
Setting range for the lower resistance (LOWER)	0.01 M Ω to 5000 M Ω [In the range of the maximum rated current or less]													
Judgement accuracy For both UPPER and LOWER	Judgement current		100 nA < i ≤ 200 nA	200nA < i ≤ 1 μA	1 μA < i ≤ 1 mA									
	UPPER, LOWER		0.01 ≤ R < 10.0 M Ω	—	—	± (2 % of setting + 3digit)								
		10.0 ≤ R < 50.0 M Ω	—	± (5 % of setting + 5digit)	± (2 % of setting + 3digit)									
		50.0 ≤ R < 100 M Ω	—	± (5 % of setting + 5digit)	± (2 % of setting + 3digit)									
		100 M Ω ≤ R < 200 M Ω	± (10 % of setting + 5digit)	± (5 % of setting + 5digit)	± (2 % of setting + 3digit)									
		200 M Ω ≤ R < 500 M Ω	± (10 % of setting + 5digit)	± (5 % of setting + 5digit)	± (2 % of setting + 3digit)									
		500 M Ω ≤ R < 1000 M Ω	± (10 % of setting + 5digit)	± (5 % of setting + 5digit)	± (2 % of setting + 3digit)									
		1000 M Ω ≤ R < 2000 M Ω	± (10 % of setting + 50digit)	± (5 % of setting + 50digit)	—									
		2000 M Ω ≤ R < 5000 M Ω	± (10 % of setting + 100digit)	± (5 % of setting + 50digit)	—									
Judgement current = test voltage / (UPPER, LOWER)														
[The humidity must be in the range of 20 %rh to 70 %rh (no condensation permitted), and there must be no disturbance such as swinging of the test leadwires.]														
[The lower judgment requires a test duration of 0.5 s or more after the wait time has expired. It also requires a wait time of 1.0 s or more for a lower judgment of 200 nA or less.]														
Time														
Setting range for the test duration (TEST TIME)	0.5 s to 999 s (TIMER OFF function provided)													
Setting range for the wait time (WAIT TIME)	0.3 s to 10 s [TEST TIME > WAIT TIME]													
Accuracy	±(100 ppm + 20 ms)													

TOS7200

Insulation Resistance Tester

Interface and Other Functions

REMOTE	6-pin mini-DIN connector on the front panel The optional remote controller RC01-TOS or RC02-TOS is connected to remotely control starting/stopping of a test (note that a DIN-mini DIN adapter is required).
SIGNAL I/O	D-SUB 25-pin connector on the rear panel For names and descriptions of connector signals.

No.	Signal name	I/O	Description of signal
1	PM0	I	LSB *1
2	PM1	I	*1
3	PM2	I	*1
4	PM3	I	MSB *1
5	N.C		
6	N.C		
7	N.C		
8	N.C		
9	STB	I	Input terminal for the strobe signal of the panel memory
10	N.C		
11	N.C		
12	N.C		
13	COM		Circuit common (chassis potential)
14	HV ON	O	ON during a test or while a voltage remains between the output terminals
15	TEST	O	ON during a test
16	PASS	O	ON for approx. 0.2 seconds when PASS judgment is made, or continuously ON while PASS HOLD is activated
17	U FAIL	O	Continuously ON if an insulation resistance equal to or exceeding the upper resistance is detected, resulting in FAIL judgment
18	L FAIL	O	Continuously ON if an insulation resistance equal to or falling below the lower resistance is detected, resulting in FAIL judgment
19	READY	O	ON during standby
20	N.C		
21	START	I	Input terminal for the START signal
22	STOP	I	Input terminal for the STOP signal
23	ENABLE	I	Remote control enable signal input terminal
24	N.C		
25	COM		Circuit common (chassis potential)

[Pin Configuration for the SIGNAL I/O Connector]



*1: 1-digit BCD active LOW input
Panel memory's selection signal input terminal
Memory recall by latching this selection signal at the rise of the strobe signal

Input specifications

High-level input voltage	11 V to 15 V	All input signals are active Low controlled. The input terminal is pulled up to +12 V using a resistor. Opening the input terminal is equivalent to inputting a high-level signal.
Low-level input voltage	0 V to 4 V	
Low-level input current	-5 mA maximum	
Input time width	5 ms minimum	

Output specifications

Output method	Open collector output (4.5 V to 30 V DC)
Output withstand voltage	30 V DC
Output saturation voltage	Approx. 1.1 V (at 25°C)
Maximum output current	400 mA (TOTAL)

ANALOG OUT Outputs a logarithmically compressed voltage corresponding to the measured resistance value

+	$V_o = \log(1 + R_x / 1M\Omega)$ where R_x = measured resistance value (1 MΩ: 0.30 V; 10 MΩ: 1.04 V; 100 MΩ: 2.00 V; 1000 MΩ: 3.00 V; 10000 MΩ or more: 4.00 V). Output impedance: 1 kΩ
COM	Analog output-circuit common
Accuracy	±(2% of full scale)

RS-232C D-SUB 9-pin connector on the rear panel (compliant with EIA-232-D)
All functions other than the POWER switch and KEY-LOCK function are remotely controllable.

Baud rate	9600 bps/19200 bps/38400 bps (data: 8 bits; parity: none; stop bit: 2 bits fixed)
-----------	--

Display 7-segment LED, 4-digit voltage display, 4-digit insulation resistance display, and 3-digit time display

Memory function A maximum of 10 types of test conditions can be stored in memory.

Backup battery life 3 years or more (at 25 °C)

TEST MODE

MOMENTARY	A test is conducted only when the START switch is pressed.
FAIL MODE	Disables cancellation of FAIL judgment using a stop signal via remote control.
DOUBLE ACTION	Starts a test only when the STOP switch is pressed and the START switch is pressed within approximately a half-second.
PASS HOLD	Allows the time of holding PASS judgment to be set to 0.2 s or HOLD.

KEYLOCK Places the tester in a state in which no keystroke other than the START/STOP switch is accepted.

General Specifications

Environment	
Installation location	Indoors and at altitudes up to 2000 m
Warranty range	Temperature 5 °C to 35 °C Humidity 20 %rh to 80 %rh (no condensation)
Operating range	Temperature 0 °C to 40 °C Humidity 20 %rh to 80 %rh (no condensation)
Storage range	Temperature -20 °C to 70 °C Humidity 90 %rh or less (no condensation)
Power requirements	
Nominal voltage range (allowable voltage range)	100 V to 240 V AC (85 V to 250 V AC)
Power consumption	30 VA maximum
At rated load	
Allowable frequency range	47 Hz to 63 Hz
Insulation resistance	30 MΩ or more (500 V DC) [AC LINE to chassis]
Hipot	1390 V AC for 2 seconds, 10 mA or less [AC LINE to chassis]
Ground bond	25 A AC/0.1 Ω or less
Electromagnetic compatibility (EMC)*1	

Conforms to the requirements of the following directive and standard.

EMC Directive 2004/108/EC
EN61326
EN61000-3-2
EN61000-3-3

Under following conditions

1. Used HV test leadwires TL08-TOS which is supplied.
2. No discharge occurs at outside of the tester.
3. Used the shielded cable which length is less than three meters when the SIGNAL I/O is used.

Safety*1, 2

Conforms to the requirements of the following directive and standard.

Low Voltage Directive 2006/95/EC
EN61010-1
Class I
Pollution degree 2

Dimensions (max.)	215 (215) W x 66 (85) H x 230 (260) Dmm
Weight	Approx. 2 kg
Accessories	AC power cable 1 pc. TL08-TOS high-voltage test leadwires (1.5 m) 1 set Operation Manual 1 copy

*1: Only on models that have CE marking on the panel. Not applicable to custom order models.

*2: This instrument is a Class I equipment. Be sure to ground the protective conductor terminal of the instrument. The safety of the instrument is not guaranteed unless the instrument is grounded properly.

External dimensional diagrams

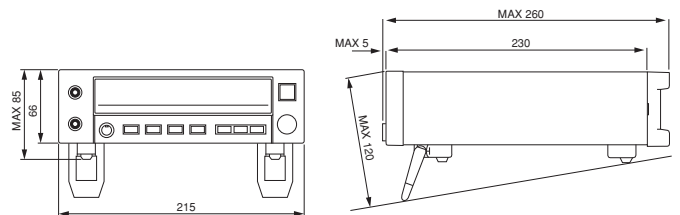

Unit: mm

TOS6210

Ground Bond Tester

Ground Bond tester supporting standard compliance tests up to 60A



TOS6210



Test up to 60A is possible!

While inheriting the basic performance and functions of its predecessor (TOS6200), such as a constant current driving system that provides current waveforms with little skew and high measurement accuracy, the TOS6210 tester extends the maximum test current from 30 A to 60 A, which is demanded by the new standard. In addition, the tester also lets you judge the acceptability of the device under test based on the drop in voltage, as required in the standard. What's more, you can preset test conditions of up to 20 different types of safety standards, such as those for information technology equipment, home appliances, medical devices, and measuring instruments, in the memory on the main unit's panel.

A simple memory call operation allows you to set up a protective earth or protective bonding continuity test as stipulated in UL60950-1 and other relevant specifications including IEC and JIS standards. The tester also features a set of functions that meet the specific needs of testing personnel, such as an offset cancellation function and a memo function that allows you to input calibration dates, production numbers, and other test-related information and read the input information later via the GPIB or RS-232C interface.

- Test current value: 6 to 60 A AC / Resistance value: 0.001 to 0.600Ω
- Voltage drop-based judgment function
- Offset cancelling function
- Stores 100 test conditions in memory
- Incorporates test conditions into program
- Contact check function
- Equipped with standard GPIB and RS-232C interfaces
- Equipped with standard test lead (TL12-TOS)

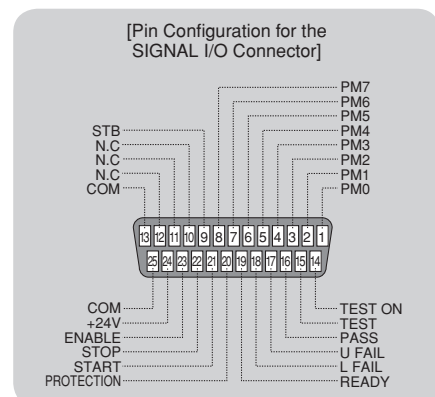

TOS6210

Ground Bond Tester

Output block		
Current setting range (*1)	6.0 to 62.0 A AC (With respect to resistance resulting in output power of the maximum rated Output or less and an output terminal voltage of 5.4 V or less)	
Resolution	0.1A	
Accuracy	± (1% of setting + 0.4A)	
Maximum rated output	220 VA (at the output terminals)	
Distortion factor	2% or less (with respect to 0.1 Ω pure resistance load of 20 A or greater)	
Frequency	50/60 Hz, sine wave (selectable)	
Accuracy	±200ppm	
Open terminal voltage	6 Vrms or less	
Output method	PWM switching method	
Output ammeter		
Measurement range	0.0 to 66.0 A AC	
Resolution	0.1A	
Accuracy	± (1% of reading + 0.4A)	
Response	Mean value response/rms value display (response time: 200 ms)	
Holding function	The current measured at the end of test is held during the PASS or FAIL interval	
Output voltmeter		
Measurement range	0.00 to 6.00 V AC	
Resolution	0.01V	
Offset cancel function	0.00 to 5.40 V (Offset ON/OFF function provided)	
Accuracy	± (1% of reading + 0.02V)	
Response	Mean value response/rms value display (response time: 200 ms)	
Holding function	The voltage measured at the end of test is held during the PASS or FAIL interval	
Ohmmeter (*2)		
Measurement range	0.001 to 0.600 Ω	
Resolution	0.001 Ω	
Offset cancel function	0.000 to 0.600 Ω (Offset ON/OFF function provided)	
Accuracy	± (2% of reading + 0.003 Ω)	
Holding function	The resistance measured at the end of test is held during the PASS or FAIL interval	
Pass/fail judgement function (*3)		
Resistance value-based judgement	Window comparator system <ul style="list-style-type: none"> •If a resistance value equal to or greater than the upper reference value is detected, a FAIL determination is returned. •If a resistance value equal to or less than the lower reference value is detected, a FAIL determination is returned. •If a resistance value has been judged as FAIL, the tester shuts off the output and generates a FAIL signal. •If the set time elapses without abnormalities, the tester shuts off the output and generates a PASS signal. 	
Setting range for the upper reference value (UPPER)	0.001 to 0.600 Ω	
Setting range for the lower reference value (LOWER)	0.001 to 0.600 Ω	
Resolution	0.001 Ω	
Judgement accuracy	± (2% of UPPER + 0.003 Ω)	
Sampled voltage value-based judgement	Window comparator system <ul style="list-style-type: none"> •If a voltage value equal to or greater than the upper reference value is detected, a FAIL determination is returned. •If a voltage value equal to or less than the lower reference value is detected, a FAIL determination is returned. •If a voltage value has been judged as FAIL, the tester shuts off the output and generates a FAIL signal. •If the set time elapses without abnormalities, the tester shuts off the output and generates a PASS signal. 	
Setting range for the upper reference value (UPPER)(*4)	0.01 to 5.40 V	
Setting range for the lower reference value (LOWER)	0.01 to 5.40 V	
Resolution	0.01 V	
Judgement accuracy	± (2% of UPPER + 0.05 V)	
Calibration		
Calibration is performed with the rms value of the sine wave, using a pure resistance load.		
LED	PASS	Lights for approximately 0.2 sec when the measured value has been judged as PASS. It is lit continuously when the PASS holding time is set to HOLD.
	UPPER FAIL	Lights if a resistance or voltage value equal to or greater than the upper reference value is detected and judged FAIL.
	LOWER FAIL	Lights if a resistance or voltage value equal to or greater than the upper reference value is detected and judged FAIL.
Buzzer		<ul style="list-style-type: none"> •The buzzer sounds for the pass holding time has been set if the measured value has been judged as PASS. •The buzzer sounds continuously under the following condition: The measured value has been judged as PASS when the PASS holding time is set to HOLD. The measured value has been judged as UPPER FAIL. The measured value has been judged as LOWER FAIL. •The buzzer volume for FAIL or PASS judgment are adjustable. <p>Note that it cannot be adjusted individually since setting is shared with the setting for PASS.</p>

*1: Time limitation with respect to output

The heat radiation capacity at the output block of the tester is designed to be one-third of the rated output, accounting for size, weight, cost, and other factors. Always use the tester within the limitation values given below. Use of the tester beyond these limits will cause the temperature of the output block to rise excessively, potentially tripping the internal protection circuit. In this case, suspend testing for approximately 30 minutes, then press the STOP switch. When temperatures fall to normal levels, the tester will revert to ready status.

Output time limitation			
Ambient temperature t (°C)	Test current I (A)	Pause time	Maximum allowable continuous test time
t ≤ 40°	40 < I ≤ 60	Equal to or greater than the test time	≤ 10 minutes
	20 < I ≤ 40	Equal to or greater than the test time	≤ 30 minutes
	I ≤ 20	Not required	Continuous output possible

*2: About ohmmeter's response time

A resistance value is instantaneously obtained, calculated using the measured voltage and current values. The response time of the ohmmeter complies with the response times of the voltmeter and ammeter.

*3: Resistance value-based and sampled voltage value-based judgments cannot be simultaneously conducted.

*4: Limited by the maximum rated output and the output terminal voltage. The tester can be used within the range shown below. Allowable range in which to determine the test current value and upper reference value

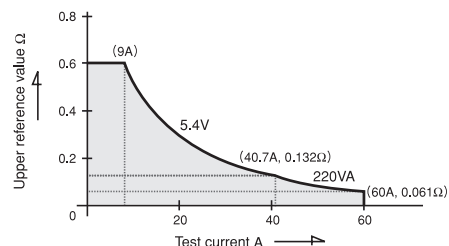

TOS6210

Ground Bond Tester

Time		
Test time	Setting range	0.3 to 999 s Timer ON/OFF function is available.
	Accuracy	± (100ppm of setting + 20ms)
Environment		
Operating environment		Indoor use, Overvoltage Category II
Warranty range	Temperature	5° to 35°C
	Humidity	20 %rh to 80 %rh (non condensing)
Operating range	Temperature	0° to 40°C
	Humidity	20 %rh to 80 %rh (non condensing)
Storage range	Temperature	-20° to 70°C
	Humidity	90 %rh or less (non condensing)
Altitude		Up to 2000m
Power requirement		
Allowable voltage range		85 to 250 V AC
Power consumption	At no load (READY)	60 VA or less
	At rated load	420 VA max.
Allowable frequency range		47 Hz to 63 Hz
Insulation resistance		30MΩ min. (500 V DC), between AC line and chassis
Hipot		1390 V AC (2 seconds), between AC line and chassis
Ground bond		25 A AC/0.1 Ω max.
Electromagnetic compatibility (EMC) (*5,6)		

Conforms to the requirements of the following directive and standard.

EMC Directive 2004/108/EC

EN61326

EN61000-3-2

EN61000-3-3

Under following conditions

1. Used test leadwire (TL12-TOS) which is supplied.
2. Used the shielded cable which length is less than three meters when the SIGNAL I/O is used.

Safety (*5)

Conforms to the requirements of the following directive and standard.

Low Voltage Directive 2006/95/EC

EN61010-1

Class I

Pollution degree 2

Physical dimensions (max)	430(455)W × 88(140)H × 270(350)Dmm
Weight	Approx. 11kg
Accessories	
AC power cord	1 piece
Test leadwire TL12-TOS	1 set
Short bar	2 pieces (These are inserted between the OUTPUT and SAMPLING terminals.)
AC power fuse	2 pieces (2, including one spare in the fuse holder)
Operation manual	1 copy

*5: Not applicable to custom order models.

*6: Only on models that have CE marking on the panel.

External dimensional diagrams

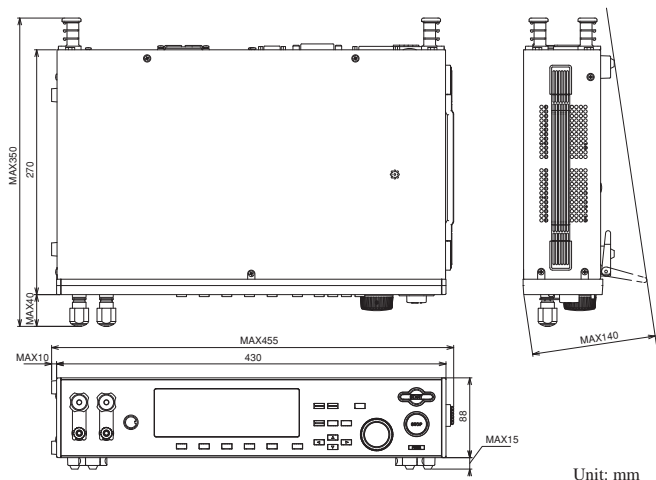

TOS6200

Ground Bond Tester

**Pursuing to maximize an easy operation,
stylish design of Ground Bond Tester**



TOS6200



Adopting the constant current method to apply automated testing system

Perfect feature for the Production line which requires reduced tact time

The TOS6200 tester is designed to perform the ground bond tests required for class-I devices by safety standards such as IEC, EN, VDE, BS, UL, JIS, and the Electrical Appliance and Material Safety Low (Japan). Equipped with a new high-efficiency power supply, it is compact and lightweight, about half the size and weight of our conventional products, while achieving a large output of 150 VA. Use of the constant current method eliminates the need to reset test currents even in the face of fluctuating resistance values for the device being tested. The test duration can also be set from 0.3 s, making the tester suitable for production line testing, which requires reduced cycle time. This tester is also designed for ease of use, featuring a large, easy-to-read display, memory capacity for storage of 100 types of test conditions, and incorporation of test conditions into programs to enable automatic testing. Standard GPIB and RS-232C interfaces allow the user to use PCs or other devices to control test conditions such as test current, resistance value for judgement, and test duration, and enables read-back of measured values and test results. The tester is also provided with test leads as standard and provides high cost effectiveness.

- Test current value: 3 to 30 A AC / Resistance value: 0.001 to 1.200Ω
- Offset cancelling function
- Stores 100 test conditions in memory
- Incorporates test conditions into program
- Contact check function
- Equipped with standard GPIB and RS-232C interfaces
- Equipped with standard test lead (TL11-TOS)

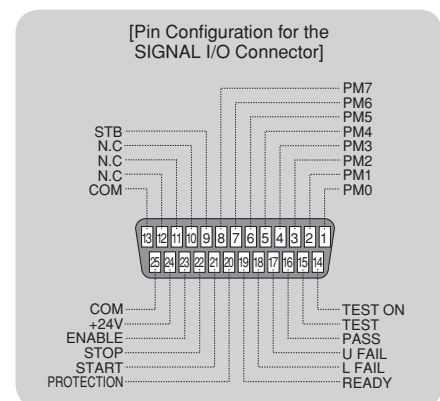

TOS6200

Ground Bond Tester

Output block		
Current setting range (*1)	3.0 to 30.0 A AC (With respect to resistance resulting in output power of the maximum rated Output or less and an output terminal voltage of 5.4 V or less)	
Resolution	0.1A	
Accuracy	± (1% of setting + 0.2A)	
Maximum rated output	150 VA (at the output terminals)	
Distortion factor	2% or less (with respect to 0.1 Ω pure resistance load of 10 A or greater)	
Frequency	50/60 Hz, sine wave (selectable)	
Accuracy	±200ppm	
Open terminal voltage	6 Vrms or less	
Output method	PWM switching method	
Output ammeter		
Measurement range	0.0 to 33.0 A AC	
Resolution	0.1A	
Accuracy	± (1% of reading + 0.2A)	
Response	Mean value response/rms value display (response time: 200 ms)	
Holding function	The current measured at the end of test is held during the PASS or FAIL interval	
Output voltmeter		
Measurement range	0.00 to 6.00 V AC	
Resolution	0.01V	
Accuracy	± (1% of reading + 0.02V)	
Response	Mean value response/rms value display (response time: 200 ms)	
Holding function	The voltage measured at the end of test is held during the PASS or FAIL interval	
Ohmmeter (*2)		
Measurement range	0.001 to 1.200 Ω	
Resolution	0.001 Ω	
Offset cancel function	0.000 to 1.200 Ω (Offset ON/OFF function provided)	
Accuracy	± (2% of reading + 0.003 Ω)	
Holding function	The resistance measured at the end of test is held during the PASS interval	
Pass/fail judgement function		
Resistance value-based judgement	Window comparator system <ul style="list-style-type: none"> •If a resistance value equal to or greater than the upper reference value is detected, a FAIL determination is returned. •If a resistance value equal to or less than the lower reference value is detected, a FAIL determination is returned. •If a resistance value has been judged as FAIL, the tester shuts off the output and generates a FAIL signal. •If the set time elapses without abnormalities, the tester shuts off the output and generates a PASS signal. 	
Setting range for the upper reference value (UPPER)	0.001 to 1.200 Ω	
Setting range for the upper reference value (LOWER)	0.001 to 1.200 Ω	
Resolution	0.001 Ω	
Judgement accuracy	± (2% of UPPER + 0.003 Ω)	
Calibration	Calibration is performed with the rms value of the sine wave, using a pure resistance load.	
LED	PASS	Lights for approximately 0.2 sec when the measured value has been judged as PASS. It is lit continuously when the PASS holding time is set to HOLD.
	UPPER FAIL	Lights if a resistance value equal to or greater than the upper reference value is detected and judged FAIL.
	LOWER FAIL	Lights if a resistance value equal to or greater than the upper reference value is detected and judged FAIL.

Buzzer	<ul style="list-style-type: none"> •The buzzer sounds for the pass holding time has been set if the measured value has been judged as PASS. •The buzzer sounds continuously under the following condition: The measured value has been judged as PASS when the PASS holding time is set to HOLD. The measured value has been judged as UPPER FAIL. The measured value has been judged as LOWER FAIL. •The buzzer volume for FAIL or PASS judgment are adjustable. Note that it cannot be adjusted individually since setting is shared with the setting for PASS.
--------	--

Time		
Test	Setting range	0.3 to 999 s Timer ON/OFF function is available.
Time	Accuracy	± (100ppm of setting + 20ms)
Environment		
Operating environment	Indoor use, Overvoltage Category II	
Warranty range	Temperature : 5° to 35°C Humidity : 20 %rh to 80 %rh (non condensing)	
Operating range	Temperature : 0° to 40°C Humidity : 20 %rh to 80 %rh (non condensing)	
Storage range	Temperature : -20° to 70°C Humidity : 90 %rh or less (non condensing)	
Altitude	Up to 2000m	
Power requirement		
Allowable voltage range	100 V model : 85 to 132 V AC 100 V/200 V model : 85 to 132 V AC/170 to 250 V AC	
Power consumption	At no load (READY)	100 V model : 70 VA or less 100 V/200 V model : 60 VA or less
	At rated load	100 V model : 450 VA max. 100 V/200 V model : 330 VA max.
Allowable frequency range	47 Hz to 63 Hz	
Insulation resistance	30MΩ min. (500 V DC), between AC line and chassis	
Hipot	1390 V AC (2 seconds), between AC line and chassis	
Ground bond	25 A AC/0.1 Ω max.	
Safety (*3)	Conforms to the requirements of the following directive and standard. Low Voltage Directive 2006/95/EC, EN61010-1, Class I, Pollution degree 2	
Electromagnetic compatibility (EMC) (*3,4)	Conforms to the requirements of the following directive and standard. EMC Directive 2004/108/EC, EN61326, EN61000-3-2, EN61000-3-3 Under following conditions 1. Used test leadwire (TL11-TOS) which is supplied. 2. Used the shielded cable which length is less than three meters when the SIGNAL I/O is used.	
Physical dimensions (max)	430(455)W × 88(140)H × 270(345)Dmm	
Weight	Approx. 9kg	
Accessories		
AC power cord	1 piece	
Test leadwire TL11-TOS	1 set	
Short bar	2 pieces (These are inserted between the OUTPUT and SAMPLING terminals.)	
AC power fuse	2 pieces (2, including one spare in the fuse holder)	
Operation manual	1 copy	

*1: Time limitation with respect to output
 The heat radiation capacity at the output block of the tester is designed to be one-third of the rated output, accounting for size, weight, cost, and other factors. Always use the tester within the limitation values given below. Use of the tester beyond these limits will cause the temperature of the output block to rise excessively, potentially tripping the internal protection circuit. In this case, suspend testing for approximately 30 minutes, then press the STOP switch. When temperatures fall to normal levels, the tester will revert to ready status.

Output time limitation			
Ambient temperature t (°C)	Test current I (A)	Pause time	Maximum allowable continuous test time
t ≤ 40°	15 < I ≤ 30	Equal to or greater than the test time	≤ 30 minutes
	I ≤ 15	Not required	Continuous output possible

*2: About ohmmeter's response time
 A resistance value is instantaneously obtained, calculated using the measured voltage and current values. The response time of the ohmmeter complies with the response times of the voltmeter and ammeter.

*3: Not applicable to custom order models.

*4: Only on models that have CE marking on the panel.

External dimensional diagrams

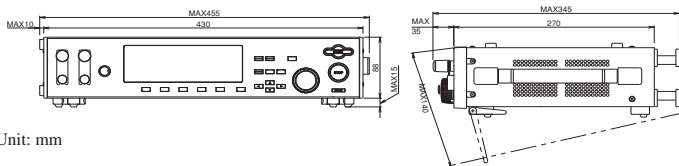

TOS3200

Leakage Current Tester

Supports touch current and protective conductor current (earth leakage current) tests



TOS3200



A leakage current tester has now been added to the TOS Series...
Conforms to international standard IEC 60990 (“Methods of measurement of touch current and protective conductor current”).

The Leakage Current Tester TOS3200 is designed to test for leakage current (Touch Current and Protective Conductor Current) of general electrical apparatuses, excluding those used for medical purposes. With this tester, you can conduct tests conforming to various standards including IEC, UL, JIS and Electrical Appliance and Material Safety Law (Japan). You can set test conditions through simple operations on the panel because this tester holds in its memory the 51 types of test conditions for IT-related electrical equipment, electrical appliances, audio & visual equipment, lighting fixtures, power tools, and measuring and control instruments, accordingly with the standards of IEC/JIS and Electrical Appliance and Material Safety Law.

- Capable of measuring leakage current in three modes
- Eight built-in measurement circuit networks
- Up to 30 mA for RMS measurement
- Easy-to-understand operation
- Enables the continuous execution of tests
- Capable of saving test results
- 51 types of standard test conditions are preset
- Lets you manage the calibration time limit
- USB interface provided as standard

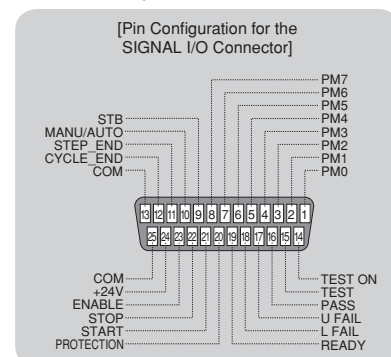

TOS3200

Leakage Current Tester

Capable of measuring leakage current in three modes

● Touch current (TC) operating mode*

Enables you to measure the touch current flowing between the enclosure (accessible portion) of the electrical equipment under test (EUT) and the power line incorporating the earth wire, via Measuring Devices. For Measuring Devices, eight measurement circuit networks (NTWKs) conforming to the applicable standards are provided as standard. The switching of the polarities of the power line to the EUT, as well as single-fault conditions, are automatically set with relays inside the tester.

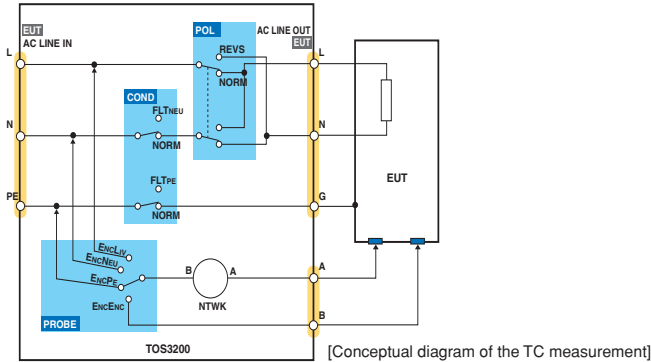

● Protective conductor current (PCC) operating mode*

Enables you to measure the current flowing through the protective conductor (earth wire) by connecting the power plug (NEMA5-15 or an equivalent) of an item of 100 V electrical equipment to the socket on the front panel. A multi-outlet is available as an option (sold separately) to accommodate the different plugs used around the world.

● Meter (METER) operating mode

In the same way as an ordinary multimeter, enables you to measure voltage and current using measurement terminals A and B on the front panel. For voltage measurement, it offers a “safety extra low voltage” (SELV) detection function; for current measurement, it offers a measurement function using measurement circuit networks (NTWKs).

*TC=Touch Current PCC=Protective Conductor Current

Easy-to-understand operation

Simple operation is possible thanks to the intuitively understandable test condition menu and the function keys/rotary knobs.

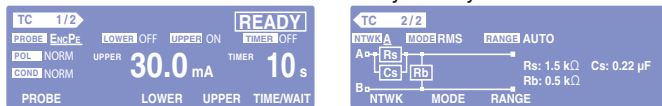

[Setting screen for touch current (TC) measurement]

Enables the continuous execution of tests

Allows you to automatically conduct TC and PCC tests as a single sequence program by setting their test conditions as up to 100 independent tests (steps). You can set up to 100 sequence programs, with up to 500 steps in total. To support automation test, measurement point (probe setting) can be switched over without turning off EUT power line.

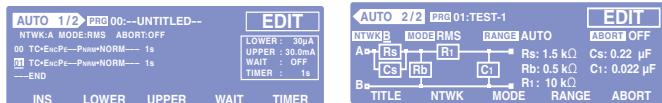

[Setting screen for auto tests]

Up to 30 mA for RMS measurement

Capable of measuring 30 μ A to 30 mA for DC/RMS measurement and 50 μ A to 90 mA for PEAK measurement, both in three ranges. Two range switching functions are provided, namely, a fixed range function (FIX) and auto range function (AUTO), which conform to the current to be measured. For RMS measurement, the “true root-mean-square value” is achieved.

Eight built-in measurement circuit networks

It offers built-in eight measurement circuit networks for measuring the touch current of general electrical equipment.

●Measurement circuit network(network A)
(comply with IEC60990 fig.3 U1 measurement)

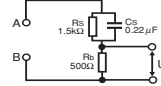

●Measurement circuit network(network D)
(Applicable standard:Electrical Appliance and Material Safety Law)

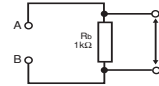

●Measurement circuit network(network B)
(comply with IEC60990 fig.4 U2 measurement)

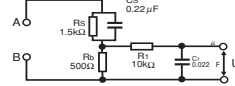

●Measurement circuit network (network E)
(Applicable standard:Electrical Appliance and Material Safety Law)

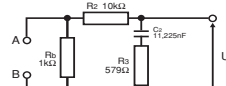

●Measurement circuit network(network B1)
(comply with IEC60990 fig.4 U1 measurement)

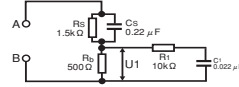

●Measurement circuit network (network F)
(Applicable standard:IEC61029 etc.)

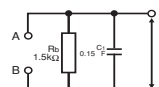

●Measurement circuit network(network C)
(comply with IEC60990 fig.5 U3 measurement)

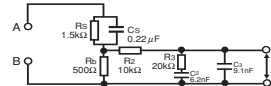

●Measurement circuit network (network G)
(Applicable standard:IEC60745 etc.)

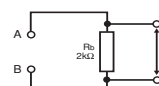

Capable of saving test results

For independent tests, enables you to save not only test results but also the test date and time and the test conditions for up to 50 tests; for auto tests, you can save this data for up to 50 programs. You can also save the test results as external records using the USB and other interfaces.

51 types of standard test conditions are preset

The memory in the main unit is pre-written with 51 types of test conditions for general electrical equipment, which conform to IEC 60990 and the standards listed below. You can set the standard test conditions merely by calling them.

[Standards covered by the memory]

Standard No.	Applicable electrical equipment
IEC60950	Information technology equipment
IEC60335	Household and similar electrical appliances
IEC60065	Audio, video and similar electronic apparatus
IEC60745	Hand-held motor-operated electric tools
IEC60598	Luminaires
IEC61010	Electrical equipment for measurement, control, and laboratory use
Electrical Appliance and Material Safety Law	Electrical appliances
IEC61029	Transportable motor-operated electric tools

Lets you manage the calibration time limit

For independent tests, enables you to save not only test results but also the test date and time and the test conditions for up to 50 tests; for auto tests, you can save this data for up to 50 programs. You can also save the test results as external records using the USB and other interfaces.

USB interface provided as standard

In addition to the SIGNAL I/O, GPIB, and RS-232C interfaces, a USB interface is also provided as standard.

Range of other functions

- “MAX function,” which retains the largest current measured.
- “CONV function,” which converts the measured current value into the corresponding value for the preset power voltage.
- “SELV function,” which causes the DANGER lamp to turn ON if a preset safety extra low voltage (SELV) is exceeded in meter measurement mode.
- “CHECK function,” which performs self-analysis of the measurement circuit networks.

TOS3200

Leakage Current Tester

Measurement item, measurement mode		
Measurement item	3 types, namely, touch current (TC) measurement, protective conductor current (PCC) measurement, and METER	
Measurement method	TC Measure the voltage drop across the reference resistor, using a measurement circuit network (NTWK), and then calculate the current.	
	PCC Measure the voltage drop across the reference resistor connected to the protective earth wire, and then calculate the current.	
	METER Measure the voltage and current using the measurement terminals.	
Measurement mode	DC/RMS/PEAK (RMS being the true root-mean-square value)	
Measurement circuit network (NTWK)	Network A Basic measurement element: (1.5 kΩ/0.22 μF) + 500 Ω	
	Network B/B1 Basic measurement element: (1.5 kΩ/0.22 μF) + 500 Ω/(10 kΩ + 0.022 μF)	
	Network C Basic measurement element: (1.5 kΩ/0.22 μF) + 500 Ω/(10 kΩ + (20 kΩ + 6.2 nF)/9.1 nF)	
	Network D Basic measurement element: 1 kΩ	
	Network E Basic measurement element: 1 kΩ/(10 kΩ + 11.225 nF + 579 Ω)	
	Network F Basic measurement element: 1.5 kΩ/0.15 μF	
	Network G Basic measurement element: 2 kΩ	
Network constant tolerance	Resistance: ±0.1%, capacitor 0.15 μF: ±2%, other: ±1%	
Current measurement section		
Measurement range	Range 1 DC/RMS: 30 μA to 600 μA, PEAK: 50 μA to 850 μA (*3)	
	Range 2 DC/RMS: 125 μA to 6.00 mA, PEAK: 175 μA to 8.50 mA (*3)	
	Range 3 DC/RMS: 1.25 mA to 30.0 mA, PEAK: 1.75 mA to 90.0 mA (*3)	
Range switching	AUTO/FIX	
Measured current (i) display/resolution	i < 1 mA: □□□ μA/1 μA, 1 mA ≤ i < 10 mA: □□□ mA/0.01 mA 10 mA ≤ i < 100 mA: □□□ mA/0.1 mA	
Measurement accuracy(*5)	Range 1	DC ±(5.0% of rdng + 20 μA)
		RMS 15 Hz ≤ f ≤ 10 kHz: ±(2.0% of rdng + 8 μA) 10 kHz < f ≤ 1 MHz: ±(5.0% of rdng + 10 μA)
		PEAK 15 Hz ≤ f ≤ 10 kHz: ±(5.0% of rdng + 10 μA)
	Range 2	DC ±(5.0% of rdng + 50 μA)
		RMS 15 Hz ≤ f ≤ 10 kHz: ±(2.0% of rdng + 20 μA) 10 kHz < f ≤ 1 MHz: ±(5.0% of rdng + 20 μA)
		PEAK 15 Hz ≤ f ≤ 1 kHz: ±(2.0% of rdng + 50 μA) 1 kHz < f ≤ 10 kHz: ±(5.0% of rdng + 50 μA)
	Range 3	DC ±(5.0% of rdng + 0.5 mA)
		RMS 15 Hz ≤ f ≤ 10 kHz: ±(2.0% of rdng + 0.2 mA) 10 kHz < f ≤ 1 MHz: ±(5.0% of rdng + 0.2 mA)
		PEAK 15 Hz ≤ f ≤ 1 kHz: ±(2.0% of rdng + 0.5 mA) 1 kHz < f ≤ 10 kHz: ±(5.0% of rdng + 0.5 mA)
	Input resistance, input capacitance	1 MΩ±1%, < 200 pF
	Common mode rejection ratio	f ≤ 10 kHz: 60 dB or greater, 10 kHz < f ≤ 1 MHz: 40 dB or greater
	Judgement function	
Judgement method	Pass/fail judgement by setting upper and lower current limits in window comparator mode	
Judgement	U-FAIL for currents above the upper limit; L-FAIL for currents below the lower limit.	
Display, etc.	U-FAIL/L-FAIL/PASS display, buzzer sounding	
PASS hold	The time for which a PASS judgement is retained can be set to 0.2 s to 10.0 s or to HOLD	
Setting range	Range 1 DC/RMS: 30 μA to 600 μA, PEAK: 50 μA to 850 μA (*4)	
	Range 2 DC/RMS: 151 μA to 6.00 mA, PEAK: 213 μA to 8.50 mA (*4)	
	Range 3 DC/RMS: 1.51 mA to 30.0 mA, PEAK: 2.13 mA to 90.0 mA (*4)	
Judgement accuracy	Conforms to measurement accuracy. (Read rdng as set.)	
Measurement of voltage between A and B		
Measurement range	DC/RMS: 10.000 V to 300.0 V, PEAK: 15.000 V to 430.0 V	
Accuracy	±(3% of rdng + 2V), measurement range fixed at AUTO	
Input impedance	Approx. 40 MΩ	
SELV detection	Set the SELV to detect; if this value is exceeded, the DANGER lamp is turned ON	
SELV setting range	10 V to 99 V, in 1-V steps, OFF function provided	
Timer, test execution function, memory		
Timer	Test wait time Setting range: 0 s to 999 s, accuracy: ±(100 ppm of set + 20 ms)	
	Test time Setting range: 1 s to 999 s/OFF function, accuracy: ±(100 ppm of set + 20 ms)	
Text execution	Auto test (AUTO): Automatic execution of up to 100 steps (test conditions) Independent test (MANUAL): Independent execution of TC, PCC, or METER measurement	
Test conditions	AUTO: Up to 100 sequence programs can be saved (up to 500 steps in total). MANUAL: Up to 100 sequence programs can be saved.	
Memory	Test results The user can select whether to save the judgement results when they are output at the end of the tests. AUTO: Test results for up to 50 programs can be recorded. MANUAL: Test results for up to 50 tests can be recorded.	
Other functions		

- The warm-up time must be 30 minutes or longer.
- rdng denotes a reading, set denotes the set value, and EUT is the electrical equipment under test.

- *1. May not apply to custom-made or modified products.
 *2. Limited to products with CE marking on their panels.
 *3. The maximum range is indicated. The range differs depending on the measurement circuit network.
 *4. The maximum range is indicated. The range differs depending on the measurement circuit network.
 Also, the UPPER setting in each range when the FIX range is selected is indicated.
 *5. Current converted value in Network A,B,C and PCC measurement, based on built-in voltmeter accuracy.

Measured value conversion (CONV)	Converts the measured current value into the corresponding value at the preset power voltage Setting range: 80.0 V to 300.0 V, OFF function provided	
MEASURE MODE	Selects a measured value from those below NORM: Displays the measured value in the measurement period MAX: Displays the largest measured value in the measurement period	
Power positive/negative phase selection (POL)	NORM: Positive phase connection, REVS: Negative phase connection	
Single fault selection (COND)	NORM: Normal, FLTNEU: Disconnection of the neutral wire, FLTPE: Disconnection of the protective earth wire	
Earth check	Generates CONTACTFAIL if the enclosure is grounded in a TC (EncLiv, EncNeu) test	
MEASURE CHECK	Checks the measurement function between measurement terminals A and B, and places the tester in the PROTECTION state if an error is detected	
Voltage measurement(EUT)	Measurement range: 80.0 V to 250.0 V, resolution: 0.1 V, accuracy: ±(3% of rdng + 1 V)	
Current measurement(EUT)	Measurement range: 0.1 A to 15.00 A, resolution: 0.01 A, accuracy: ±(5% of rdng + 30 mA)	
Power measurement (effective power)	Measurement range: 10 W to 1500 W Accuracy (at a power voltage of 80 V or higher and a load power factor of 1): ±(5% of rdng + 8 W)	
System clock	Recording	Items: Calibration date and time, test date and time, permissible date and time: Up to 2099
	Calibration time limit management(CAL PROTECT)	Enables the setting of a calibration time limit. Once this time has passed, a warning is output as power on ON: Places the tester in the PROTECTION state (disables the use of the tester), OFF: Displays warning.
Protective operation	Relay operation error, overload, over range, measurement function check, failure of internal battery, etc.	
Interface		
RS-232C	D-Sub 9-pin connector (conforming to EIA-232D), baud rate: 9600/19200/38400 bps (For connection to a PC, use a "9-pin female-female reverse" cable.)	
GPIO	Conforms to IEEE Std. 488-1978. (SH1,AH1,T6,TE0,L4,LE0,SR1,PP0,DC1,DT0,CO,E1)	
USB	USB Specification 2.0	
REMOTE	6-pin MINIDIN connector (for HP21-TOS (separately sold option) only)	
SIGNAL I/O	25-pin D-Sub connector	
General		
Measurement terminals	Rated voltage/current	Terminals A to B: 250 V, terminal to chassis: 250 V, 100 mA
	Measurement category	CAT II
	Effective terminal display	Terminals effective to measurement are indicated with LED lamps.
Environment	Specification assured range	Temperature: 5°C to 35°C, humidity: 20% rh to 80% rh (no condensation)
	Operating range	Temperature: 0°C to 40°C, humidity: 20% rh to 80% rh (no condensation)
	Storage range	Temperature: -20°C to 70°C, humidity: 90% rh or less (no condensation)
Power	Mounting location	Indoors, altitude of 2000 m or less
	Input power for EUT	Nominal input rating: 100Vac to 240Vac, 50/60Hz Rated output capacity: 150 VA, maximum current: 15 A, rush current: 70 A peak max. (within 20 ms)
	Insulation resistance	30 MΩ or greater (500 Vdc) (between AC line and chassis, between measurement terminal and chassis)
Withstand voltage	1390 Vac, 2 seconds/20 mA or less (between AC line and chassis)	
Ground bond	25 Aac/0.1 Ω or less	
Safety (*1)	Conforms to the requirements of the directive and standard below. Low Voltage Directive 2006/95/EC, EN61010-1 (Class I, Pollution degree 2)	
Electromagnetic compatibility (*1, *2)	Conforms to the requirements of the directive and standard below. EMC Directive 2004/108/EC, EN61326, EN61000-3-2, EN61000-3-3, Applicable conditions: All cables and wires used to connect to this product must be shorter than 3 meters. Use the supplied test leads.	
Outside dimensions, weight	320 (345) W × 88 (105) H × 270 (335) D mm, approx. 5 kg	
Accessories	1 set of test leads (TL21-TOS: red and black, one each, with alligator clips) 1 flat probe (FP01-TOS), 1 spare fuse (15A, for EUT power) 1 instruction manual, 1 circuit principle diagram sticker 2 power cords (for the tester and for the EUT AC line)	

External dimensional diagrams

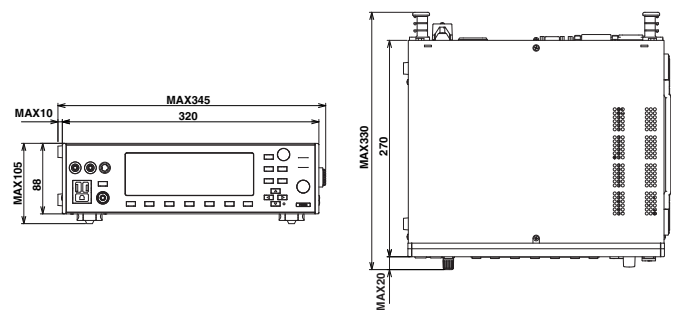

Unit: mm

High-Voltage Digital Voltmeter

■ 149-10A



- Measurement of high voltages (AC/DC) of up to 10 kV maximum.
- Large 4 1/2 digit LED display
- High measuring accuracy and input resistance
- Light weight of only 3.2 kg
- Compact design
- Excellent ease of maintenance

Specifications	
Operating System	Double integration system (sampling cycle: 3 times/sec)
DC Voltage	Measuring range: 0.500kV to 10,000kV Accuracy: $\pm(0.5\%$ of reading + 0.03% of range) Input resistance: 1000 M Ω \pm 2%
AC Voltage	Measuring range: 0.500kV to 10,000kV Accuracy: $\pm(1\%$ of reading + 0.05% of range) Frequency characteristics: 50/60 Hz (sine wave rms value display of mean value response) Input resistance: 1000 M Ω \pm 2%
Power Requirements	100V \pm 10%, approx. 10 VA
Dimensions (MAX)	134W \times 164H \times 270D mm (140W \times 189H \times 350D mm)
Weight	approx. 3 kg
Accessories	TL05-TOS high-voltage test lead: 1 HTL-2.5DH high-voltage coaxial cable: 1

Hipot Tester Current Calibrator

■ TOS1200 *While Supplies Last



- Calibration of Leakage Current Detection Sensitivity
- Direct Reading of Error from Error Display Scale
- Ammeter Ranges
- Eliminates Need for Power Supply
- AC/DC Selection Switch

Specifications			
Measuring Function	Measurement of current values and error(%) for AC (50/60 Hz) and DC at a test voltage of 1000 V		
Measuring Ranges	8 ranges consisting of 0.5/1/2/5/10/20/50/100 mA along with values equal to 0.8 times the values of those ranges (for 1, 2, 4 and 8 steps)		
Ammeter Scale	Main scale: Direct-reading error display scale over a range of $\pm 10\%$ of the above full scale values Auxiliary scale: Ratio scale of 0 to 1.1 times the above full scale values (equivalent to 0% display of main scale when the ratio is equal to 1)		
Ammeter Accuracy	Main scale: $\pm 1\%$ of reading Auxiliary scale: $\pm 3\%$ of full scale value		
Ammeter Indication	DC/AC (sine wave rms value calibration of mean value response)		
Load Resistance			
Range[mA]	Resistance[k Ω]	Range[mA]	Resistance[k Ω]
0.5	2000	10	100
1	1000	20	50
2	500	50	20
5	200	100	10
Allowed Input Time	0.5/1/2/5 mA ranges: Continuous 10/20/50/100 mA ranges: 60 sec. Max. 1/3 of duty cycle		
Dimensions (MAX)	134W \times 164H \times 270D mm (140W \times 189H \times 320D mm)		
Weight	approx. 3.5 kg		
Accessories	TL04-TOS high-voltage test lead: 1		

UL Resistance Load

■ RL01-TOS



This device is described in section 125, paragraph 2-1B1 of UL1492. The RL01-TOS is a variable load resistor for checking the output voltage of hipot testers used in dielectric strength testing on production lines. (Complies with UL regulations including UL1270, UL1409 and UL1410.)

Specifications	
Resistors:	120, 159, 210, 279, 369, 489, 648, 858, 1,137, 1,500, 1,989 and 2,148 kW
Resistance Accuracy	+1%,-0% of nominal value when set to 120 kW, $\pm 1\%$ of nominal value when set to other values
Maximum Operating Voltage	1300 V (continuous rating)
Maximum Overload Voltage	1400 V for 5 seconds (application may not be repeated within 1 minute)
Dimensions (MAX)	200W \times 100H \times 260D mm (210W \times 120H \times 295D mm)
Weight	approx. 2.6 kg
Accessories	TL04-TOS high-voltage test lead: 2 TL05-TOS high-voltage test lead: 1

Calibration Resistor for Insulation Resistance Tester

■ 929-1M
■ 929-10M
■ 929-100M



The 929 Series Standard Resistors are for calibration of Insulation Testers.

Specifications			
Model	929-1M	929-10M	929-100M
Nominal resistance	1M Ω	10M Ω	100M Ω
Accuracy of resistance	1% at 25°C \pm 10°C		
Temperature coefficient	100 ppm/°C or better		
Voltage coefficient	1 ppm/V or better		
Working voltage rating	1.2 kV		
Dimensions (MAX)	64W \times 24H \times 30D mm		

*The 929 series standard resistors can not be installed directly to the TOS series. Please use the test lead for connection.

Option

Test Lead

■ TL01-TOS

[cable length: 1.5 m/max. operating voltage: 5 kV]



■ TL02-TOS

[cable length: 3 m/max. operating voltage: 5 kV]



■ TL03-TOS

[cable length: 1.5 m/max. operating voltage: 10 kV]



■ TL04-TOS

[cable length: 1.5 m/max. operating voltage: 5 kV
(for TOS1200, RL01-TOS)]



■ TL05-TOS

[cable length: 1.5 m/max. operating voltage: 5 kV
(for 149-10A, RL01-TOS)]



■ TL06-TOS

[cable length: 0.5 m/max. operating voltage: 5 kV
(for parallel connection of TOS9220/9221)]



■ TL07-TOS

[cable length: 1.5 m/max. operating voltage: 5 kV
(for TOS9220/9)]



■ TL08-TOS

[cable length: 1.5 m/max. operating voltage: 1 kV
(for TOS7200)]



■ TL11-TOS

[cable length: 1.5 m/max. operating current: 30 A
(for TOS6200)]



■ TL12-TOS

[cable length: 1.5 m/max. operating current: 60 A
(for TOS6210)]



■ TL21-TOS [cable length: 1.5 m (for TOS3200)]



■ TL31-TOS

[cable length: 1.5 m/max. operating voltage: 5 kV
(for TOS5300 Series)]



■ TL32-TOS

[cable length: 3 m/max. operating voltage: 5 kV
(for TOS5300 Series)]



■ HTL-2.5DH

[cable length: 1.5 m/max. operating voltage: 10 kV
(for 149-10A)]



Remote Control Box

■ RC01-TOS *1 *2

[one-hand operation/dimensions: 200W × 70H × 39D mm]
Accessory cable length: 1.5 m

■ RC02-TOS *1 *2

[both-hands operation/dimensions: 330W × 70H × 39D mm]
Accessory cable length: 1.5 m



RC01-TOS

RC02-TOS

*1: The optional Adaptor DD-5P/6P is required for the connection with TOS7200.

*2: The optional Adaptor DD-5P/9P is required for the connection with TOS5300 Series.

DIN Cable

■ DD-3 5P

[cable length: 3 m/DIN plug to DIN plug]



■ DD-5P/6P

[Adaptor / DIN to Mini DIN]



■ DD-5P/9P

[Adaptor /DIN to Mini DIN]



Test Probe

■ HP01A-TOS *3

[cable length: 1.8 m/max. operating voltage: 4 kV
AC(RMS), 5kV DC]

■ HP02A-TOS *3 *4

[cable length: 3.5 m/max. operating voltage: 4 kV
AC(RMS), 5kV DC]

*3: The optional Adaptor DD-5P/9P is required for the connection with TOS5300 Series.

*4: This can not be used with TOS7200.



■ HP11-TOS

[cable length: 1.8m/max.operating voltage: 1kV DC/
max.operating current: 100mA (for TOS7200)]



■ HP21-TOS

[cable length: 1.8m/max.operating voltage: 250Vrms/
max.operating current: 100mA (for TOS3200)]



Option

■LP01-TOS

[cable length: 2 m/max. operating current: 30 A
(for TOS6200)]



■LP02-TOS

[cable length: 2 m/max. operating current: 60 A
(for TOS6210)]



■FP01-TOS

(flat probe for TOS3200)



Buzzer Unit

■BZ01-TOS (for 100V AC)

* This can not be used with TOS6200,
TOS9200/9201, TOS7200



Warning Light Unit

■PL01-TOS (for 100V AC)

* This can not be used with TOS6200,
TOS9200/9201, TOS7200



■PL02-TOS (for 24V DC)

* for TOS9200/9201, TOS5300 Series



Multi Outlet

■OT01-TOS

(multi outlet for TOS3200)



Rack Mount Bracket

Product Name	JIS Standard	EIA Standard
	Bracket Model No	Bracket Model No.
TOS9201	KRB150-TOS	KRB3-TOS
TOS9213S	KRB150-TOS	KRB3-TOS
TOS9200	KRB150-TOS	KRB3-TOS
TOS9220	KRB100-TOS	KRB2-TOS
TOS9221	KRB100-TOS	KRB2-TOS
TOS8870A	KRB150-TOS	KRB3-TOS
TOS5302	KRA200-TOS	KRA4-TOS
TOS5301	KRA200-TOS	KRA4-TOS
TOS5300	KRA200-TOS	KRA4-TOS
TOS6200	KRB100-TOS	KRB2-TOS
TOS6210	KRB100-TOS	KRB2-TOS
TOS3200	KRB150-TOS	KRB3-TOS



KIKUSUI ELECTRONICS CORPORATION

1-1-3, Higashiyamata, Tsuzuki-ku, Yokohama, 224-0023, Japan

Phone: (+81) 45-593-7570, Facsimile: (+81) 45-593-7571, www.kikusui.co.jp

KIKUSUI AMERICA, INC. 1-877-876-2807 www.kikusuiamerica.com



530 Lakeside Drive, Suite#180, Sunnyvale, CA 94085, U.S.A.
Phone : 408-733-3432 Facsimile : 408-733-1814

KIKUSUI TRADING (SHANGHAI) Co., Ltd. www.kikusui.cn



Room, D-01,11F, Majesty Bld, No.138, Pudong Ave, Shanghai City
Phone : 021-5887-9067 Facsimile : 021-5887-9069

For our local sales distributors and representatives, please refer to "sales network" of our website.

●Distributor:

■ All products contained in this catalogue are equipment and devices that are premised on use under the supervision of qualified personnel, and are not designed or produced for home-use or use by general consumers. ■ Specifications, design and so forth are subject to change without prior notice to improve the quality. ■ Product names and prices are subject to change and production may be discontinued when necessary. ■ Product names, company names and brand names contained in this catalogue represent the respective registered trade name or trade mark. ■ Colors, textures and so forth of photographs shown in this catalogue may differ from actual products due to a limited fidelity in printing. ■ Although every effort has been made to provide the information as accurate as possible for this catalogue, certain details have unavoidably been omitted due to limitations in space. ■ If you find any misprints or errors in this catalogue, it would be appreciated if you would inform us. ■ Please contact our distributors to confirm specifications, price, accessories or anything that may be unclear when placing an order or concluding a purchasing agreement.

Printed in Japan

Issue:Mar.2011 2011030.2KSOHEC61