

HSC 4-8 COUPLING NETWORK

COUPLING/DECOUPLING ASSEMBLY FOR UNSHIELDED AND SHIELDED HIGH-SPEED COMMUNICATION LINES UP TO 1GBIT/S

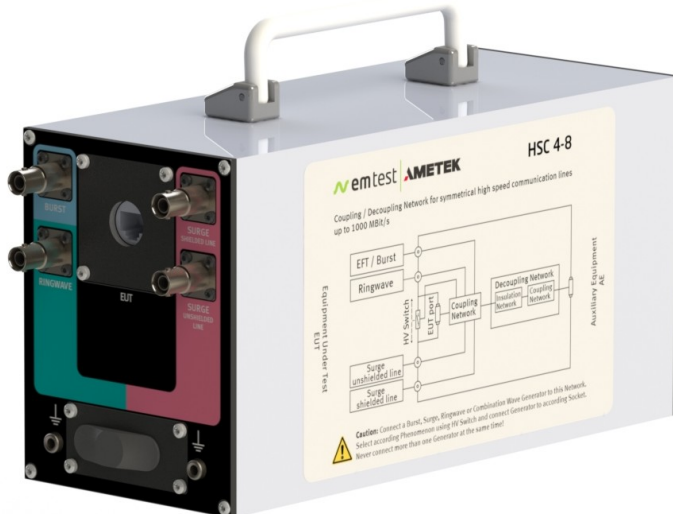

FOR TESTS ACCORDING TO ...

- > EN 61000-4-12
- > EN 61000-4-4
- > EN 61000-4-5
- > EN 61000-6-1
- > EN 61000-6-2
- > IEC 61000-4-12
- > IEC 61000-4-4
- > IEC 61000-4-5

COUPLING/DECOUPLING ASSEMBLY FOR UNSHIELDED AND SHIELDED HIGH-SPEED COMMUNICATION LINES

The HSC 4-8 from AMETEK CTS is the first coupling/decoupling network available on the market to couple Surge onto shielded and unshielded high-speed communication lines with data rates up to 1,000MBit/s. Additionally, the HSC 4-8 can be used as a coupling/decoupling network to apply Burst- as well as Ringwave pulses to shielded and unshielded lines. The HSC 4-8 meets the requirements according Figure 15 and Figure 16 to the standards IEC 61000-4-5 (Ed. 2.0 :2005) and IEC 61000-4-5 (Ed. 3.0 :2014) Figure 11 and Figure 12.

HIGHLIGHTS

- > Coupling to unshielded and shielded lines with up to 4 pairs
- > Data transfer up to 1,000 MBit/s
- > Surge test voltage up to 3 kV (1.2/50 us)
- > Burst test voltage up to 4 kV (5/50 ns)
- > Ringwave test voltage up to 4 kV (0.5 us/100 kHz)
- > Residual voltage max. 50 V at 3 kV Surge
- > Compatible to PoE and PoE+ requirements

APPLICATION AREAS

-  TELECOM
-  INDUSTRY
-  RESIDENTIAL
-  MILITARY

TECHNICAL DETAILS

HSC 4-8 - COUPLING- DECOUPLING NETWORK

COUPLING NETWORK FOR COUPLING OF THE SURGE, BURST AND RINGWAVEIMPULSE TO UNSHIELDED AND SHIELDED HIGH-SPEED COMMUNICATION LINES

The HSC 4-8 is specially designed for the testing of high-speed communication lines. It allows data transfers up to 1,000 Mbit / s without affecting the signal.

It also supports PoE and PoE + standard requirements as per IEEE 802.3af-2003 and IEEE 802.3at-2009.

The HSC 4-8 includes two surge pulse inputs. One for direct coupling to lines and one for coupling to the cable shield (see tests to shielded cables as per IEC 61000-4-5).

Surge: Direct coupling

Using series resistors, as specified in the standard, the surge pulses are coupled onto the unshielded symmetrical Interconnection lines.

The HSC 4-8 includes all necessary resistors and coupling elements to couple the 1,2 / 50us impulse (max. 3 kV) up to 4 pairs of high-speed communication lines.

The picture below shows the normative design of the coupling-decoupling network.

Fig. 15 IEC 61000-4-5 (Ed. 2.0 :2005)

Fig. 11 IEC 61000-4-5 (Ed. 3.0 :2014)

Burst:

A separate coaxial input is used for couple the EFT /Burst impulse to shielded datalines. The decoupling part of the CNI 508N2 decouples the EFT pulses in direction to the AE Port.

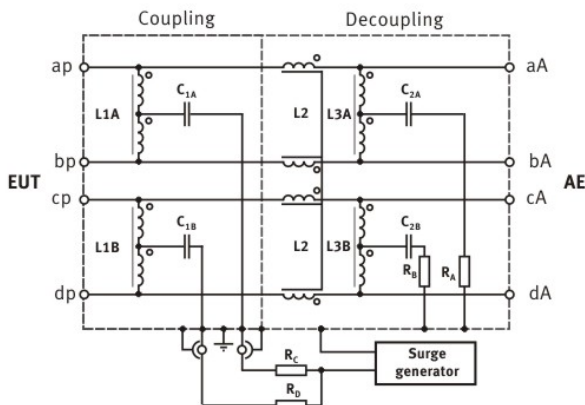

IEC 61000-4-5 (Ed. 2.0 : 2005) Fig. 15
IEC 61000-4-5 (Ed. 3.0 : 2014) Fig. 11

COUPLING TO THE SCREENED LINES

TEST OF SHIELDED LINES AS PER IEC 61000-4-5

Up today, the surge test on shielded data cable had a complicated and hazardous test setup with long cables and additional galvanically isolated power supplies.

With the innovative HSC 4-8 this test / test setup get much easier. The accessory is correct decoupled and the surge pulse is coupled directly to the shield of the tested cable and not applied to the conductive housing.

The HSC 4-8 allows further test requirements: Burst and Ringwave pulses (0.5 us/100 kHz) with coupling to shielded cables.

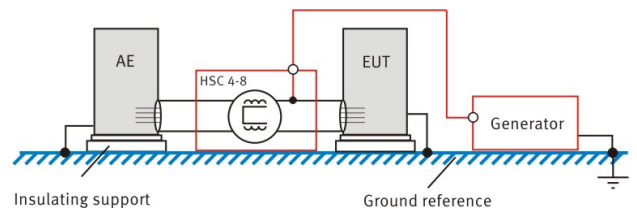

POE UND POE+ REQUIREMENTS

TEST SET-UP WITH POE AND POE+ SUPPLY

The power supply input for PoE and PoE + applications is on the protected side (AE) of the coupling / decoupling network.

The power supply is fed through the HSC 4-8 to the DUT. The voltage range for PoE and PoE + supplies is standardized from 36 V to 57 V.

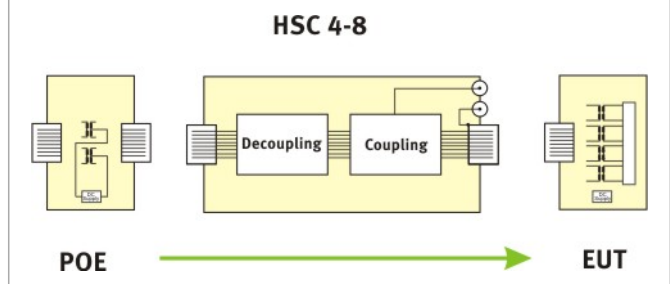

TECHNICAL DETAILS

CONNECTION AE PORT

DEVICE PROTECTION ON AE PORT

The impulse at the AE-port of the decoupling network is damped. The CNI 508N2 has an additional integrated overvoltage protection that limits the residual voltage below 40 V @2 kV and <50 V @4 kV between line and earth.

This protection level allows to use PoE (Power over Ethernet) power supply inside the specified voltages range from 36V to 57V.

This protection level is for some application cases too high and can destroy your expensive auxiliary equipment connected at the AE port. Thus AMETEK CTS has developed an additional protective element SPN 508N1

SPN 508N1 SURGE PROTECTION OPTION

SURGE PROTECTION NETWORK FOR UNSHIELDED AND SHIELDED HIGH-SPEED COMMUNICATION LINES

The optional SPN 508N1 is required to appropriately decouple the surge pulses from the auxiliary equipment. The residual voltage at the AE port is limited to max. 10V@2 kV surge voltage level. Its specific design allows the full data transfer up to 1000 MBit/s without causing signal degradation.

The HSC 4-8 limits the residual voltage to 50 V. This voltage may destroy your precious accessories. The SPN 508N1 with its low protection level 10 V is therefore the ideal protection for all other tests with high voltage.



HSC 4-8 - COUPLING/DECOUPLING NETWORK FOR SHIELDED AND UNSHIELDED LINES

SURGE TEST MODE

Coupling mode	shielded and unshielded cable with up to 4 pairs
Test voltage	Max. 3 kV* (1.2/50us) (* only with connected RJ45 connector; if left open the max. test voltage is limited to 1.5 kV)
Residual voltage	Max. 50V @3 kV Surge, line - PE

RINGWAVE TEST MODE

Coupling mode	shielded and unshielded cable with up to 4 pairs
Test voltage	Max. 4 kV* (0.5 us/100 kHz) (* only with connected RJ45 connector; if left open the max. test voltage is limited to 1.5 kV)
Residual voltage	Max. 50V @2 kV Ringwave, line - PE Max. 50V @4 kV Ringwave

BURST TEST MODE

Coupling mode	shielded cable with up to 4 pairs
Test voltage	Max. 4 kV* (5/50 ns) (* only with connected RJ45 connector; if left open the max. test voltage is limited to 1.5 kV)
Residual voltage	Max. 40 V @2 kV Burst, line - PE Max. 60 V @4 kV Burst

TELECOM LINE SPECIFICATIONS

Input/Output	RJ45 female connectors for telecom lines
Terminal layout	Pair 1: pins 1/2 Pair 2: pins 3/6 Pair 3: pins 4/5 Pair 4: pins 7/8
Data rate	up to 1,000 MBit/s
Protection	+ - 60 V between two pairs
Operating voltage	max. 57 VDC
Operating current	max. 1 A

TECHNICAL DETAILS

HSC 4-8 - COUPLING/DECOUPLING NETWORK FOR SHIELDED AND UNSHIELDED LINES

INPUTS	
Surge/Ringwave shield	SHV connector
Surge unshielded	SHV connector
Ringwave unshielded	SHV connector
Burst	SHV connector

GENERAL DATA	
Dimensions	270 mm x 110 mm x 140 mm (LxWxH)
Weight	6.5 kg
Temperature	5°C - 40°C (operation)
Rel. humidity	10 % - 90 %, non condensing

OPTION SPN 508N1 - SURGE PROTECTION NETWORK FOR UNSHIELDED AND SHIELDED LINES

SURGE TEST MODE	
Number of lines	4 twisted pairs
Max. discharge current	2 kA (8/20 us) without destruction to the RJ45 contacts
Residual voltage	max. 10 V
Insertion loss	< -1.5 dB (300 kHz - 100 MHz)

TELECOM LINE SPECIFICATION	
Input/Output	RJ45 female connectors for telecom lines
Terminal layout	Pair 1: pins 1/2 Pair 2: pins 3/6 Pair 3: pins 4/5 Pair 4: pins 7/8
Data rate	up to 1,000 MBit/s

GENERAL DATA	
Dimensions	115 mm x 80 mm x 80 mm (LxWxH)
Weight	0.7 kg
Temperature	5°C - 40°C (operation)
Rel. humidity	10 % - 90 %, non condensing

COMPETENCE WHEREVER YOU ARE



CONTACT EM TEST DIRECTLY

Switzerland

EM TEST (Switzerland) GmbH › Sternenhofstraße 15 › 4153 Reinach › Switzerland
Phone +41 (0)61/7179191 › Fax +41 (0)61/7179199
Internet: www.emtest.ch › E-mail: sales.emtest@ametek.com

Germany

AMETEK CTS Germany GmbH › Lünener Straße 211 › 59174 Kamen › Deutschland
Phone +49 (0)2307/26070-0 › Fax +49 (0)2307/17050
Internet: www.emtest.com › E-mail: info.cts@ametek.de

France

EM TEST FRANCE › Le Trident - Parc des Collines › Immeuble B1 - Etage 3 › 36, rue Paul Cézanne › 68200 Mulhouse › France
Phone +33 (0)389 31 23 50 › Fax +33 (0)389 31 23 55
Internet: www.emtest.fr › E-mail: info@emtest.fr

Poland

EM TEST Polska › ul. Ogrodowa 31/35, 00-893 Warszawa › Polska
Phone +48 (0)518 64 35 12
Internet: www.emtest.com/pl › E-mail: infopolska.emtest@ametek.com

USA / Canada

AMETEK Compliance Test Solutions › 52 Mayfield Ave. › Edison › NJ 08837
Phone +1 (732) 417-0501
Internet: www.emtest.com › E-mail: sales.emtest@ametek.com

P.R. China

E & S Test Technology Limited › Rm 913, Leftbank › No. 68 Bei Si Huan Xi Lu › Haidian District › Beijing 100080 › P.R. China
Phone +86 (0)10 82 67 60 27 › Fax +86 (0)10 82 67 62 38
Internet: www.emtest.com › E-mail: info@emtest.com.cn

Republic of Korea

EM TEST Korea Limited › #405 › WooYeon Plaza › #986-8 › YoungDeok-dong › Giheung-gu › Yongin-si › Gyeonggi-do › Korea
Phone +82 (31) 216 8616 › Fax +82 (31) 216 8616
Internet: www.emtest.co.kr › E-mail: sales@emtest.co.kr

Information about scope of delivery, visual design and technical data correspond with the state of development at time of release. Subject to change without further notice.